

Rosemount™ 2160 Wireless Level Switch

Vibrating Fork



WirelessHART™



- World's first wireless liquid level switch for reliable point level detection
- Wireless capabilities extend the full benefits of PlantWeb™ to previously inaccessible locations
- Self-organizing network delivers information rich data with >99% data reliability
- Designed for operation in temperature extremes of -94 to 500 °F (-70 to 260 °C)
- Virtually unaffected by flow, bubbles, turbulence, foam, vibration, solids content, coating, properties of the liquid, and product variations
- “Fast Drip” fork design gives quicker response time, especially with viscous liquids
- Intrinsically Safe certification option
- TÜV tested and approved for overfill protection according to DiBt/ WHG regulations

Overview of the Rosemount 2160 Wireless Level Switch



2160**S

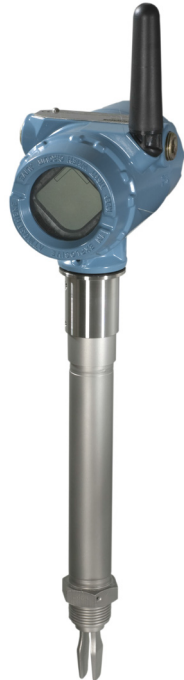

2160**E



'Fast drip' forks

Measurement principle

The Rosemount 2160 is designed using the principle of a tuning fork. A piezo-electric crystal oscillates the forks at their natural frequency. Changes to this frequency are continuously monitored. The frequency of the vibrating fork sensor changes depending on the medium in which it is immersed. The denser the liquid, the lower the frequency.

When used as a **low level alarm**, the liquid in the tank or pipe drains down past the fork, causing a change of natural frequency that is detected by the electronics and switches the output state to 'dry'.

When the Rosemount 2160 is used as a **high level alarm**, the liquid rises in the tank or pipe, making contact with the fork which then causes the output state to switch to 'wet'.

Key features and benefits

- Virtually unaffected by turbulence, foam, vibration, solids content, coating, or liquid properties
- The high temperature version of the Rosemount 2160 is designed for operation in temperatures from -94 to 500 °F (-70 to 260 °C). It has a stainless steel thermal tube to move the electronics away from the process
- Electronic self-checking and condition monitoring, and alerts using a Field Communicator or AMS Device Manager.
- Software adjustable switching delay prevents false switching in turbulent or splashing applications
- Wireless and encrypted digital communication of the switch output state and other variables
- Optional integral LCD for indicating the switch output state and diagnostics
- 'Fast Drip' fork design gives quicker response time, especially with viscous liquids. Rapid wet-to-dry time for highly responsive switching
- Fork shape is optimized for hand polishing to meet hygienic requirements
- No moving parts or crevices for virtually no maintenance

Contents

Ordering Information	page 4	Product Certifications	page 11
Spares and Accessories	page 7	Dimensional Drawings	page 13
Specification	page 8		

Superior diagnostics

- Built-in diagnostics continuously check electronic and mechanical health
- Fork conditions detected including internal and external damage, coated or blocked, and extreme corrosion
- Ideal for critical alarm duties

Fit and forget

- Once installed, the Rosemount 2160 is ready to go. It needs no calibration and requires minimum installation
- You can install, and forget it

Wireless power module

- The Rosemount 2160 is powered by a replaceable wireless Power Module
- The fork sensor requires very little power, and the Power Module life remains long even with fast update rates

Extended temperature performance

- The high temperature version of the Rosemount 2160 enables standardization of Emerson’s™ vibrating fork switches across a wide range of process environments, and is ideally suited for harsh conditions where high reliability is essential

Wireless capability

- The Rosemount 2160 is the world’s first wireless liquid level switch
- Includes all the features of our wired level switches, but without the complications and cost of wiring
- Ideal for level detection in locations previously inaccessible, or too costly for wired devices

Applications

- Overfill protection
- High and low level alarms
- Pump control or limit detection
- Run dry or pump protection
- Hygienic applications
- High temperature applications



AMS Device Manager

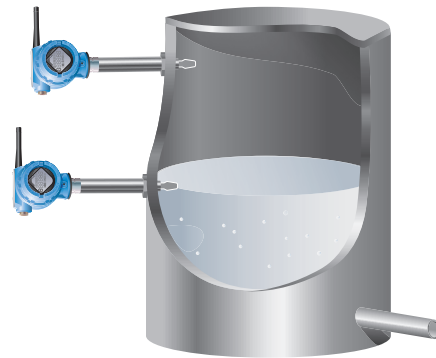

High and low level alarm

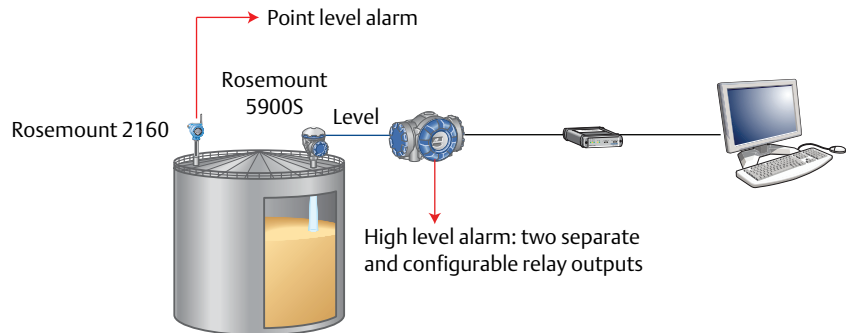

For optimal performance, every wireless HART network should have a minimum of five devices and every device should have a minimum of three neighbors within effective range of the wireless gateway

Ordering Information

Specification and selection of product materials, options, or components must be made by the purchaser of the equipment. See [page 9](#) for more information on Material Selection.

Table 1. Rosemount 2160 Ordering Information

The starred options (★) represent the most common options and should be selected for best delivery. The non-starred offerings are subject to additional delivery lead time.

Model	Product description	
2160	Wireless Vibrating Fork Liquid Level Switch	
Output		
X	Wireless	★
Housing material		
D	Dual Compartment Housing - Aluminum (Aluminium)	★
Conduit entry / cable threads		
8	1/2-in. NPT thread	★
Operating temperature		
S	Standard: -40 °F (-40 °C)...302 °F (150 °C)	★
E	High: -94 °F (-70 °C)...500 °F (260 °C)	★
Material of construction: process connection / fork		
S ⁽¹⁾	316/316L Stainless Steel (1.4401/1.4404)	★
H ⁽²⁾	Alloy C (UNS N10002), Alloy C-276 (UNS N10276), solid	
Process connection size		
9	3/4 in. / 19 mm	★
1	1 in. / 25 mm (DN25)	★
2	2 in. / 50 mm (DN50)	★
5	1 1/2 in. / 40 mm (DN40)	★
3	3 in. / 80 mm (DN80)	★
4	4 in. / 100 mm (DN100)	★
7	2 1/2-in. / 65 mm (DN65)	★
X ⁽³⁾	Customer specific	
Process connection rating		
AA	ASME B16.5 Class 150 flange	★
AB	ASME B16.5 Class 300 flange	★
DB	EN1092-1 PN25/40 flange	★
NN	For use with non-flange process connection type	★
AC	ASME B16.5 Class 600 flange	
DA	EN1092-1 PN10/16 flange	
DC	EN1092-1 PN63 flange	
DD	EN1092-1 PN100 flange	
XX ⁽³⁾	Customer specific	

Table 1. Rosemount 2160 Ordering Information

The starred options (★) represent the most common options and should be selected for best delivery. The non-starred offerings are subject to additional delivery lead time.

Process connection type		
R	Raised Face (RF) flange	★
B	BSPT (R) thread	★
G	BSPP (G) thread	★
N	NPT thread	★
P	BSPP (G) O-ring	★
C	Tri Clamp	★
X ⁽³⁾	Customer specific	
Fork length		
A	Standard length 1.7-in. (44 mm)	★
H ⁽⁴⁾	Standard length flange 4.0-in. (102 mm)	★
E ⁽⁵⁾	Extended, customer specified length in tenths of inches	★
M ⁽⁵⁾	Extended, customer specified length in millimeters	★
Specific extended fork length		
0000	Factory default length (only if fork length A or H is selected)	★
xxxx ⁽⁵⁾	Specific customer specified length in tenths of inches or millimeters (xxx.x inches or xxxx mm)	★
Surface finish		
1	Standard surface finish	★
2 ⁽⁶⁾⁽⁷⁾	Hand polished (Ra < 0.4 μm)	★
Product certifications		
GP	Korean Testing Laboratory (KTL), KCC Mark for Ordinary Locations	★
I2	INMETRO Intrinsic Safety	★
I3	NEPSI Intrinsic Safety	★
I5	FM Intrinsic Safety	★
I6 ⁽⁸⁾	CSA Intrinsic Safety	★
I7	IECEX Intrinsic Safety	★
IM	Technical Regulation Customs Union (EAC) Intrinsic Safety	★
IP	KTL/KOSHA Intrinsic Safety	★
Wireless update rate, operating frequency and protocol		
WA3	User configurable update rate, 2.4 GHz DSSS, IEC 62591 (WirelessHART™)	★
Omni-directional wireless antenna and SmartPower		
WK1 ⁽⁹⁾	External antenna, adapter for black power module (I.S. power module sold separately)	★
Typical model number: 2160 XD 8 S S 1 NN N A0000 1 I5 WA3 WK1		

Table 1. Rosemount 2160 Ordering Information

The starred options (★) represent the most common options and should be selected for best delivery. The non-starred offerings are subject to additional delivery lead time.

Options (include with the selected model number)

Meter		
M5	LCD meter	★
Factory configuration ⁽¹⁰⁾		
C1	Factory configure Date, Descriptor, Message Fields and Wireless Parameters	★
Calibration data certification		
Q4	Certificate of functional test	★
Material traceability certification		
Q8	Material traceability certification per EN 10204 3.1	★
Special procedures ⁽¹¹⁾		
P1	Hydrostatic testing with certificate	★
Example of options included with the model number: 2160 X D 8 S S 1 NN N A0000 1 I5 WA3 WK1 M5 Q8		

1. Flanges are dual certified 316 and 316L Stainless Steel (1.4401 and 1.4404).
2. Only available for BSPT and NPT threaded process connection types as standard, other upon request.
3. Other process connections available upon request.
4. Not available for hand polished wet side.
5. Example: Code E1181 is 118.1 inches. Code M3000 is 3000 millimeters. See “Extended fork lengths” on page 8 for minimum and maximum extended lengths.
6. Not available with Material of Construction Process / Fork option code H.
7. Hand-polished for hygienic connections to better than 0.4 µm Ra such that there are no pits, folds, crevices or cracks discernible to the naked eye (i.e. no features larger than 75 micrometers based on resolving 1/60 degree at a distance of 250 mm).
8. The requirements of CRN are met when a Rosemount 2160 is configured with a CSA approval, 316/316L stainless steel (1.4401/1.4404) wetted parts, and either NPT threaded or 2-in. to 4-in. ASME B16.5 flanged process connections.
9. Black power module must be shipped separately, order Model 701PBKFF or part number 00753-9220-0001.
10. Submit a completed [Configuration Data Sheet \(CDS\)](#) with the order if the C1 option code is selected.
11. Option limited to units with extended lengths up to 59.1-in. (1500 mm).

Overfill approval option

The Rosemount 2160 has been TÜV-tested and approved for overfill protection according to the German DIBt/WHG regulations. If required, add “R2259” to the end of the model code. For example, 2160 X D 8 S S 1 NN N A0000 1 I5 WA3 WK1 **R2259**. You can have one or more Options codes added to the end of the model code.

Spares and Accessories

Specification and selection of product materials, options, or components must be made by the purchaser of the equipment. See [page 9](#) for more information on Material Selection.

Table 2. Rosemount 2160 Spares and Accessories

The starred options (★) represent the most common options and should be selected for best delivery. The non-starred offerings are subject to additional delivery lead time.

Part number	Description	
02100-1000-0001	Seal for 1-in. BSPP (G1A). Material: Non-asbestos BS7531 grade X carbon fiber with rubber binder	★
02100-1040-0001	Seal for 3/4-in. BSPP (G3/4A). Material: Non-asbestos BS7531 grade X carbon fiber with rubber binder	★
02100-1010-0001	Adapter boss, 1-in. BSPP to 1 1/2-in. (38 mm) Tri Clamp. Material: 316 stainless steel fitting, FPM/FKM 'O' ring	★
02100-1020-0001	2-in. (51 mm) Tri Clamp kit (vessel fitting, clamp ring and seal). Material: 316 stainless steel, NBR Nitrile	★

Specification

General

Product

Rosemount 2160 Wireless Level Switch

Measuring technology

Vibrating fork

Applications

Liquids including coating liquids, aerated liquids, and slurries. Suitable for horizontal and vertical installations.

Physical

Material selection

Emerson provides a variety of Rosemount product with various product options and configurations including materials of construction that can be expected to perform well in a wide range of applications. The Rosemount product information presented is intended as a guide for the purchaser to make an appropriate selection for the application. It is the purchaser's sole responsibility to make a careful analysis of all process parameters (such as all chemical components, temperature, pressure, flow rate, abrasives, contaminants, etc.), when specifying product, materials, options and components for the particular application.

Emerson is not in a position to evaluate or guarantee the compatibility of the process fluid or other process parameters with the product, options, configuration or materials of construction selected.

Electronics housing

Enclosure

Housing: Stainless steel or low-copper aluminum

Paint: Polyurethane (aluminum housing only)

Cover O-ring: Nitrile butadiene

Terminal block and power module pack

PBT

Antenna

PBT/PC integrated omni-directional antenna

Rotation

Rotatable housing allows correct alignment of both the forks and the omni-directional antenna for optimal signal and best viewing position of the LCD integral display.

Ingress protection

Housing is NEMA 4X and IP66 compliant.

Process wetted connections

Connections

Threaded, Tri Clamp, and flanged process connection options. See [Table 1 on page 4](#) for a complete list.

Materials

316/316L stainless steel (1.4401/1.4404 dual-certified). Hand-polished to better than 0.4 μm option for Tri Clamp connections.

Alloy C (UNS N10002) and Alloy C-276 (UNS N10276) – available for flanged, and selected threaded process connections (3/4- and 1-in. BSPT (R), and 3/4- and 1-in. NPT).

Gasket material for 3/4-in. and 1-in. BSPP (G) is non-asbestos BS7531 Grade X carbon fiber with rubber binder. Gaskets are not supplied with flanged process connections.

Extended fork lengths

The maximum extended length is 118.1 in. (3000 mm) for all except for hand-polished option where the maximum is 39.4 in. (1000 mm).

[Table 3](#) has a summary of the minimum extended lengths. See "[Dimensional Drawings](#)" on [page 13](#) for other dimensions.

Table 3. Minimum extended lengths

Process connection	Minimum extended length
3/4-in. threaded	3.8 in. (95 mm)
1-in. threaded	3.7 in. (94 mm)
Flanged	3.5 in. (89 mm)
Tri Clamp	4.1 in. (105 mm)

Performance

Electromagnetic Compatibility (EMC)

All models meet all relevant requirements of EN 61326

Hysteresis (water)

±0.039 in. (±1 mm) nominal

Switching point (water)

0.5 in. (13 mm) from fork tip if mounted vertically.

0.5 in. (13 mm) from the fork edge if mounted horizontally.

The switching point varies with different liquid densities.

Liquid density range

Minimum liquid density is 31.2 lb/ft³ (500 kg/m³).

Liquid viscosity range

0.2 to 10000 cP (centiPoise)

Humidity limits

0 to 100% relative humidity

Solids content and coating

The maximum recommended diameter of solid particles in the liquid is 0.2 in. (5 mm). Avoid bridging of forks (fork-to-fork).

CIP (Clean In Place) cleaning

The Rosemount 2160 withstands steam cleaning.

Electrical

Wireless power module

Replaceable, intrinsically safe Lithium-Thionyl Chloride power module with PBT enclosure.

Ten year life at one minute update rate.

Reference conditions are 70 °F (21 °C), and routing data for three additional network devices. Continuous exposure to ambient temperature limits -40 °F or 185 °F (-40 °C or 85 °C) may reduce specified power module life by 20 percent.

Field communicator connections

Clips are permanently fixed to the terminal block.

Functional

Output

IEC 62591 (WirelessHART) 2.4 GHz DSSS

Radio frequency power output from antenna

Maximum of 10 mW (10 dBm) EIRP

Wireless update rate

User-selectable: from one second up to sixty minutes.

The optional integral LCD display updates at each wireless update.

Local display

A 'locate device' function allows easy identification of instrument during commissioning inspection.

The optional five-digit integral LCD can indicate a sequence of up to four process variables (dry/wet, electronics temperature, frequency, and supply voltage) and diagnostic information.

Environmental

Maximum operating pressures

Threaded connection: See Figure 1

Hygienic connection: 435 psig (30 bar g)

Flanged connection:

The maximum operating pressure is the lower of the process pressure (Figure 1) and flange pressure rating (Table 4)

Figure 1. Operating Pressures

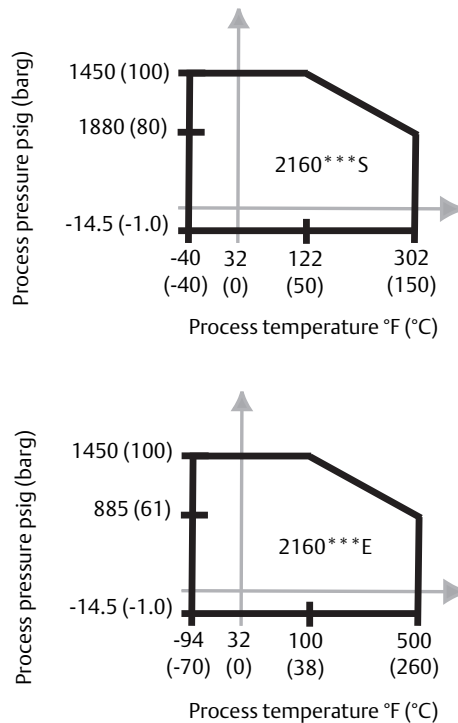

Table 4. Maximum Flange Pressure Rating

Flange standard	Stainless steel flanges ⁽¹⁾
ASME B16.5 Class 150	275 psig ⁽²⁾
ASME B16.5 Class 300	720 psig ⁽²⁾
ASME B16.5 Class 600	1440 psig ⁽²⁾
EN1092-1 PN 10/16	16 bar g ⁽³⁾
EN1092-1 PN 25/40	40 bar g ⁽³⁾
EN1092-1 PN 63	63 bar g ⁽³⁾
EN1092-1 PN 100	100 bar g ⁽³⁾

1. ASTM stainless steel.
2. At 100 °F (38 °C), the pressure rating decreases with an increasing process temperature.
3. At 122 °F (50 °C), the pressure rating decreases with an increasing process temperature.

Note

The final maximum operating pressure rating depends on the process (tank) connection.

Maximum and minimum operating temperatures

See [Figure 2 on page 10](#) for the maximum and minimum operating temperatures.

Figure 2. Operating Temperatures

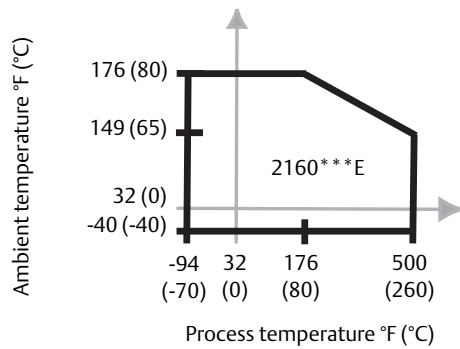
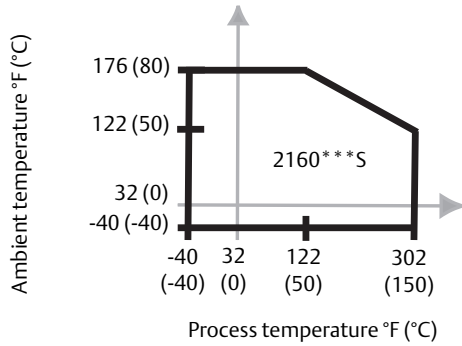

Product Certifications

European Union directive information

The EC declaration of conformity certificate is currently not available for the Rosemount 2160. Please check the Rosemount 2160 [web page](#) for updates.

Telecommunication compliance

All wireless devices require certification to ensure that they adhere to regulations regarding the use of the RF spectrum. Nearly every country requires this type of product certification. Emerson is working with governmental agencies around the world to supply fully compliant products and remove the risk of violating country directives or laws governing wireless device usage.

FCC and IC

This device complies with part 15 of the FCC Rules. Operation is subject to the following two conditions: (1) This device may not cause harmful interference, and (2) this device must accept any interference received, including interference that may cause undesired operation.

This device must be installed to ensure a minimum antenna separation distance of 8 in. (20 cm) from all persons.

Korean Testing Laboratory (KTL), KCC mark for ordinary locations use

GP EMC certificate: KCC-REM-ERN-RMDSWIT2160XXX

Overfill approval

Certificate number: Z-65.11-518

TÜV-tested and approved for overfill protection according to the German DIBt/WHG regulations. Certified under safety devices for tanks and piping related to water pollution control.

Drinking water approval

Rosemount Measurement Limited, Slough, UK confirms that the wetted parts of the Rosemount type 2160 vibrating level switches are suitable and approved for use in potable water.

The wetted parts of the vibrating level switches executed in: Stainless steel (option code S) and Alloy C / Alloy C-276 (option code H) with Flanged (option code R), NPT thread (option code N), BSPT(R) thread (option code B) or Tri-clamp (option code C) process connections, are in accordance with the requirements of DVGW* - Worksheet W270. The materials used are classified as toxicologically and microbiologically.

NAMUR approval

NAMUR NE95 type test report available upon request. Complies with NAMUR NE21

Canadian Registration Number

CRN 0F04227.2C

The requirements of CRN are met when a Rosemount 2160 CSA-approved vibrating fork level switch model is configured with 316/316L stainless steel (1.4401/1.4404) process-wetted parts and either NPT threaded or 2-in. to 4-in. ASME B16.5 flanged process connections.

Hazardous locations certificates

North America and Canada

Factory Mutual (FM) approvals

- I5** Project ID: 3036541
 FM Intrinsic Safety, Non-incendive, and Dust Ignition-proof
 Intrinsically Safe for:
 Class I/II/III, Division 1, Groups A, B, C, D, E, F, and G
 Zone Marking: Class I, Zone 0, AEx ia IIC
 Temperature Codes T4 ($T_{amb} = -50$ to 70 °C)
 Non-incendive for Class I, Division 2, Groups A, B, C, and D
 Dust Ignition-proof for Class II/III, Division I, Groups E, F, G
 Ambient temperature limits: -50 to 70 °C
 For use with Rosemount SmartPower® options
 P/N 753-9220-0001 only.
 Enclosure Type 4X / IP66

Special condition for safe use

- Warning – Potential Electrostatic Charging Hazard – The enclosure is partially constructed from plastic. To prevent the risk of electrostatic sparking, use only a damp cloth to clean the plastic surfaces.

Canadian Standards Association (CSA) approval

- I6** Certificate Number: 06 CSA 1786345
 CSA Intrinsically Safe
 Intrinsically Safe for Class I, Division 1, Groups A, B, C and D
 Temperature Code T3C
 Enclosure Type 4X / IP66
 Intrinsically Safe when installed in accordance with Rosemount drawing 71097/1271.
 For use with Rosemount SmartPower options
 P/N 753-9220-0001 only.
 Single seal

International approvals

Technical Regulation Customs Union (EAC) approvals

IM Certificate: RU-C-GB.AB72.B.00916
Intrinsic Safety:
0Ex ia IIC T5...T2 Ga X
Ta (see table in the certificate)

KTL/KOSHA approvals

IP Certificate: 13-KB4BO-0213X
Ex ia IIC T5...T2
Ta (see table in the certificate)

IECEx approval

I7 IECEx Intrinsic Safety
Certificate Number: IECEx BAS 09.0123X
Ex ia IIC T5-T2 (Ta = -40 to 70 °C)
IP66
For use with Rosemount SmartPower options
P/N 753-9220-0001 only.

Special conditions for safe use

1. The surface resistivity of the antenna is greater than one gigaohm. To avoid electrostatic charge build-up, it must not be rubbed or cleaned with solvents or a dry cloth.
2. Warning – potential electrostatic charging hazard – The enclosure is partially constructed from plastic. To prevent the risk of electrostatic sparking, use only a damp cloth to clean the plastic surfaces.

National Supervision and Inspection Centre (NEPSI) approval

I3 NEPSI Intrinsic Safety
Certificate: GYJ101138X
Ex ia IIC T5-T2

Special condition for safe use

1. Symbol “X” is used to denote specific conditions of use:
 - a. Model 648 WTT or Model 3051S WPT type battery pack provided by the manufacturer should be used.
 - b. The surface resistivity of the antenna is greater than one gigaohm. To avoid electrostatic charge build-up, it must not be rubbed or cleaned with solvents or a dry cloth.
 - c. The Rosemount 2160 enclosure is made of aluminum alloy and given a protective epoxy coating. However, care should be taken to protect it from impact or abrasion if located in a Zone 0.

Dimensional Drawings

Figure 3. 3/4- and 1-in. Threaded Process Connections (Standard Length Fork)

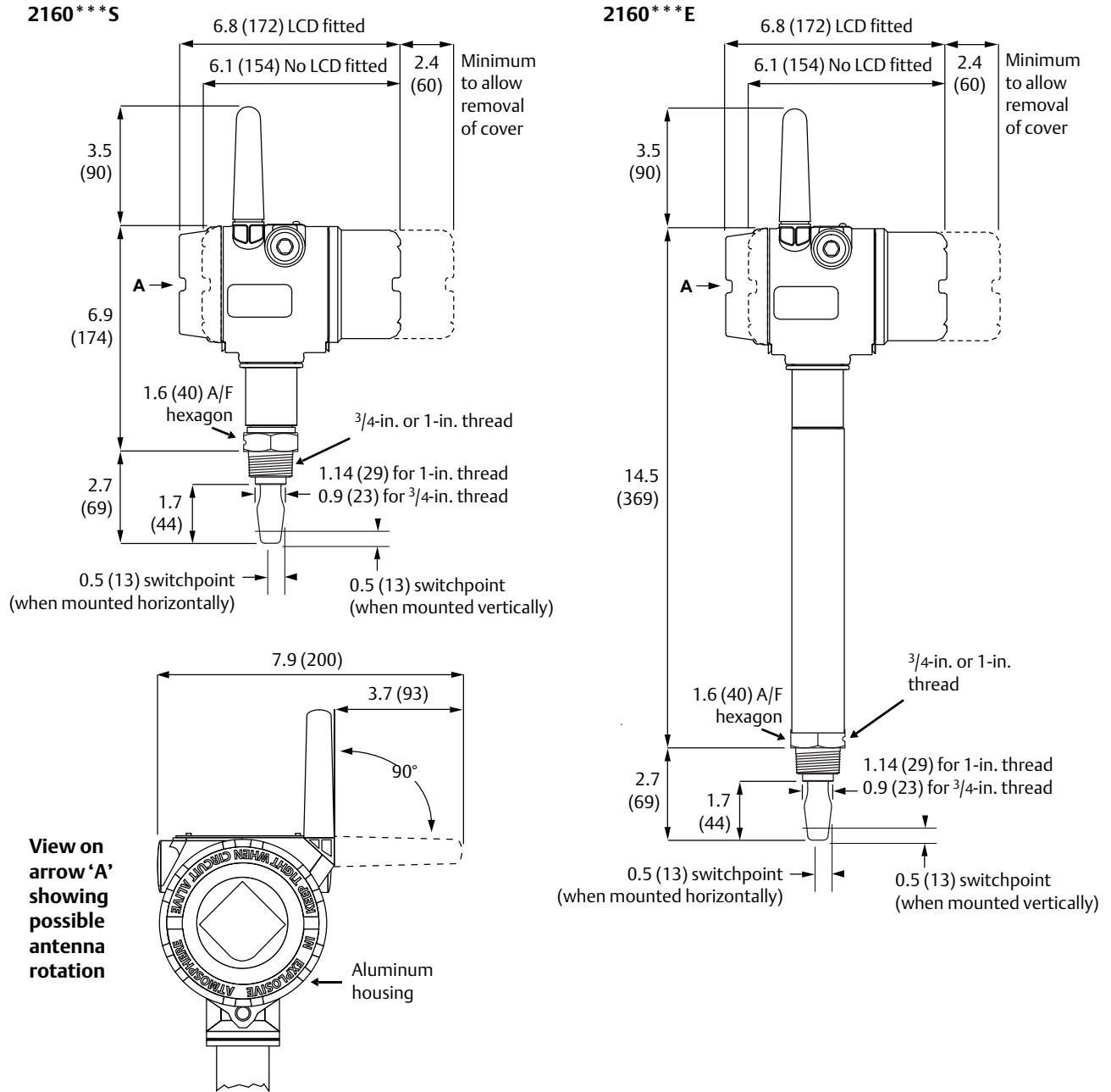

Dimensions are in inches (millimeters).

Refer to the Type 1 drawings on the Rosemount 2160 [web page](#) for dimensions of the O-ring seal (BSPP) versions.

Figure 4. 3/4- and 1-in. Threaded Process Connections (Extended Length Fork)

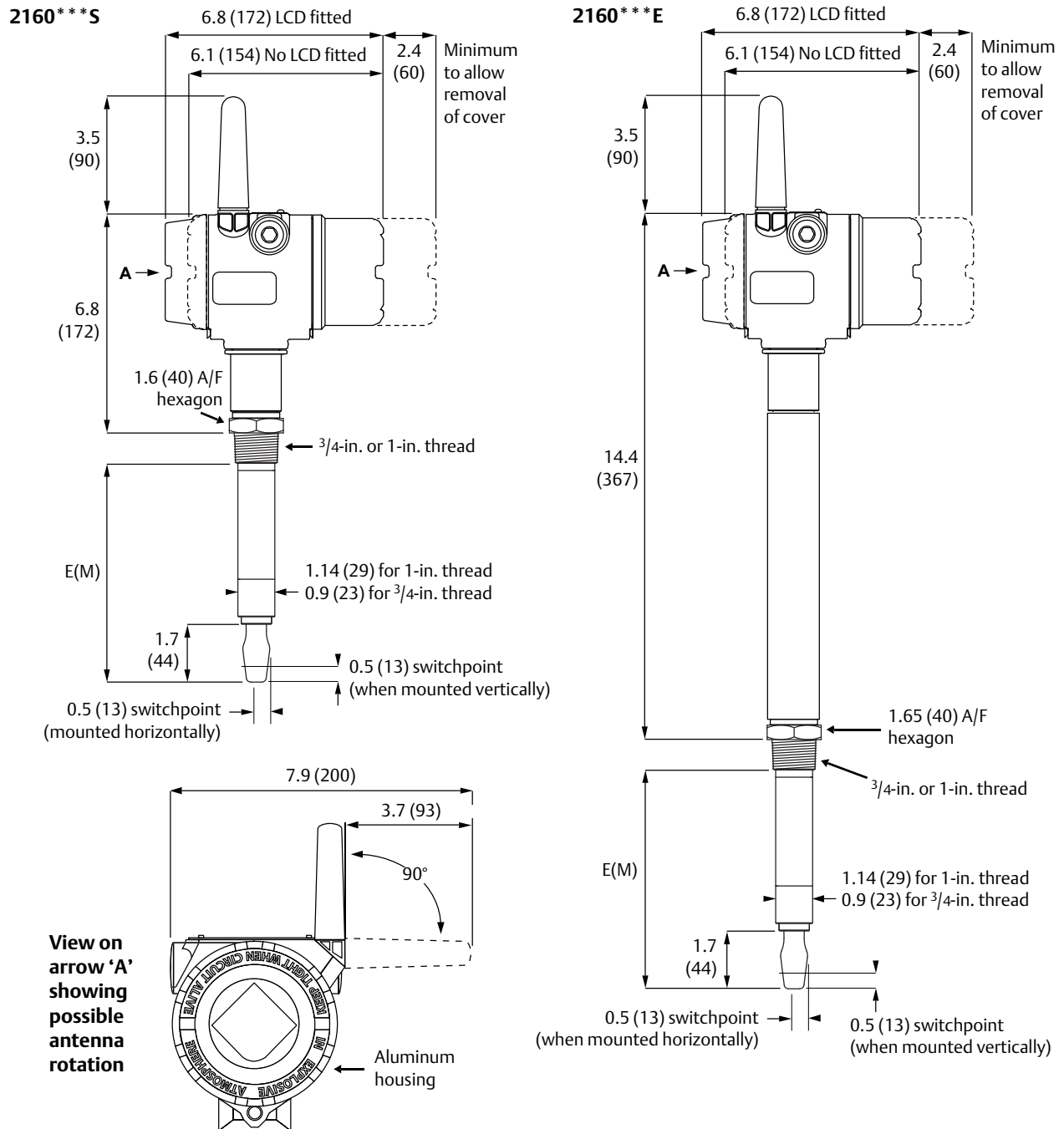

Dimensions are in inches (millimeters). See Type 1 drawings on the Rosemount 2160 [web page](#) for dimensions of the O-ring seal (BSPP) versions.

Table 5. Fork Length for 3/4- and 1-in. Threaded Rosemount 2160

Process connection	Standard length fork length code A	Minimum length fork length code E (M)	Maximum length fork length code E (M) ⁽¹⁾
3/4-in. thread	1.73 in. (44 mm)	3.75 in. (95 mm)	118.1 in. (3000 mm)
1-in. thread	1.73 in. (44 mm)	3.74 in. (94 mm)	118.1 in. (3000 mm)

1. Maximum extended length of fork with hand-polished option is 39.4 in. (1000 mm).

Figure 5. Flanged Process Connections (Standard Length Fork)

2160***S

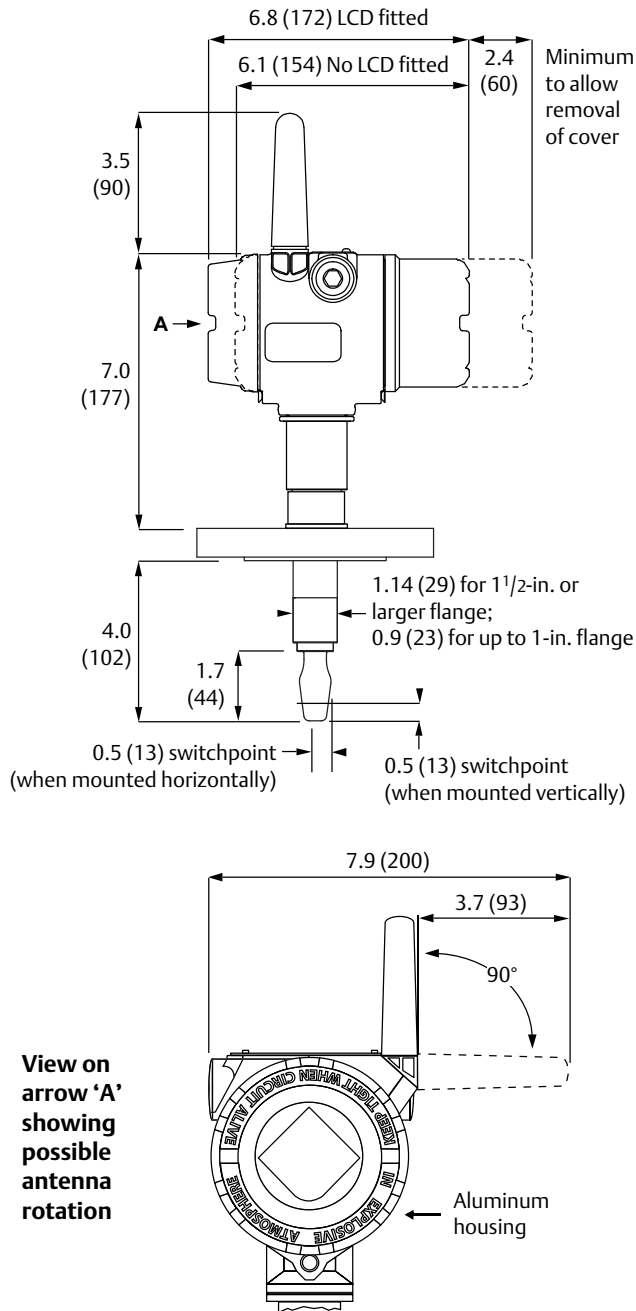

2160***E

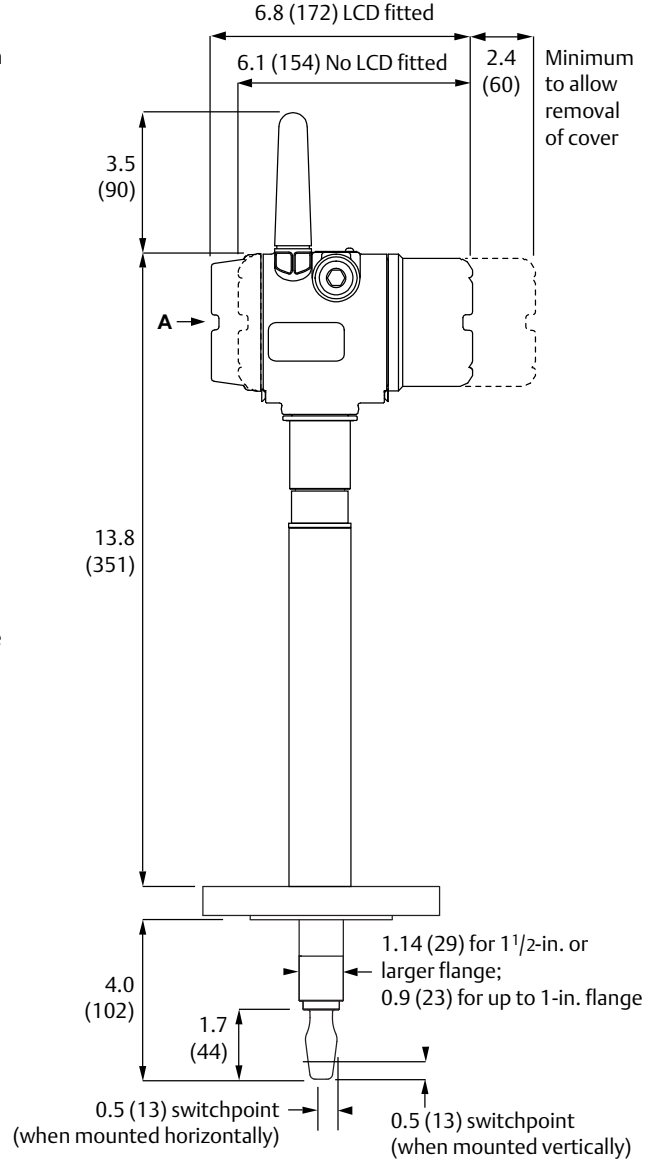

Dimensions are in inches (millimeters).

Figure 6. Flanged Process Connections (Extended Length Fork)

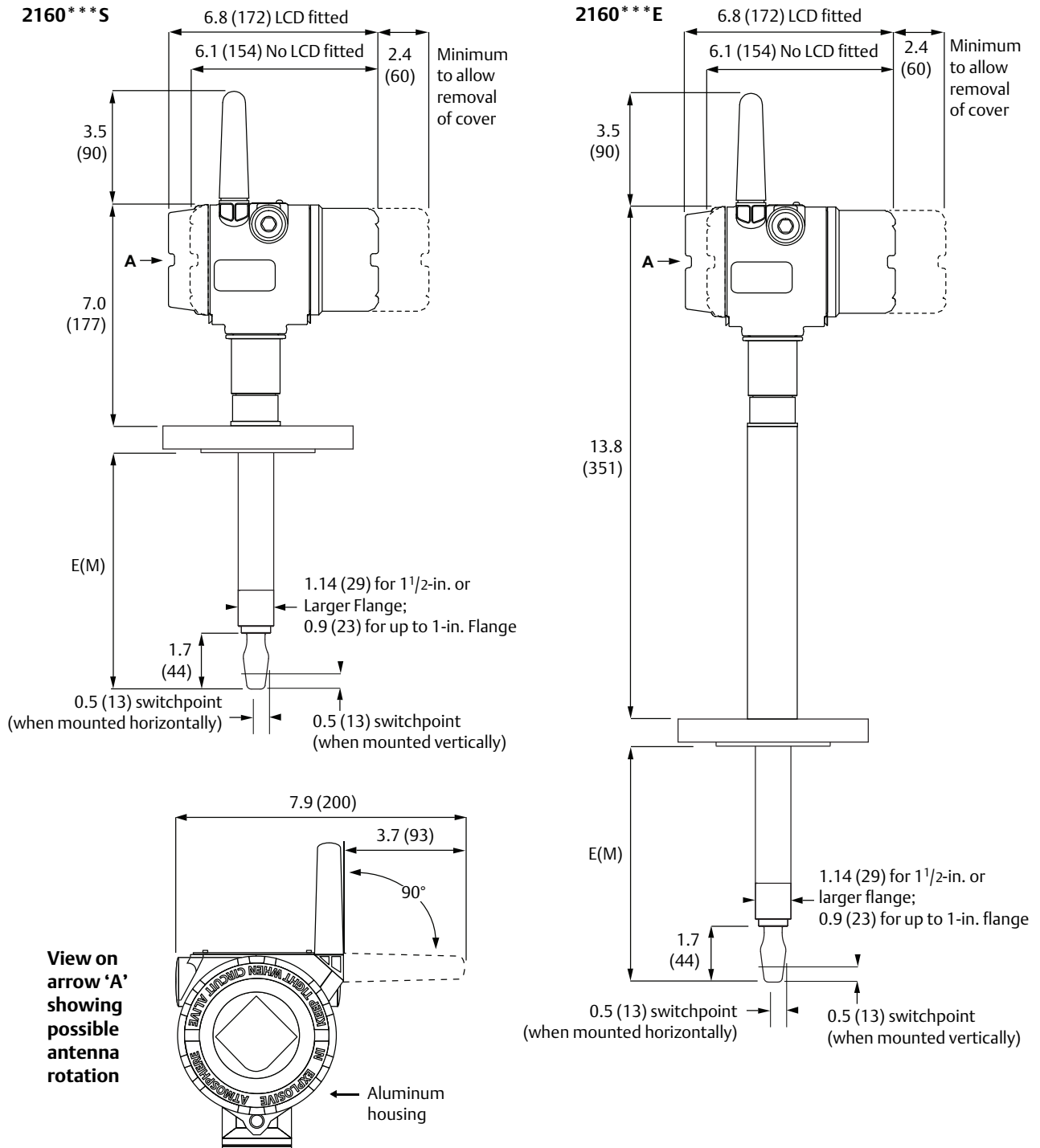

Dimensions are in inches (millimeters).

Table 6. Fork Length for Flanged Rosemount 2160

Process connection	Standard length fork length code H	Minimum length Fork length code E(M)	Maximum length fork length code E(M)
3/4-in., 1-in. or larger flange	4.0 in. (102 mm)	3.7 in. (94 mm)	118.1 in. (3000 mm)

Figure 7. Tri Clamp Process Connections (Standard Length Fork)

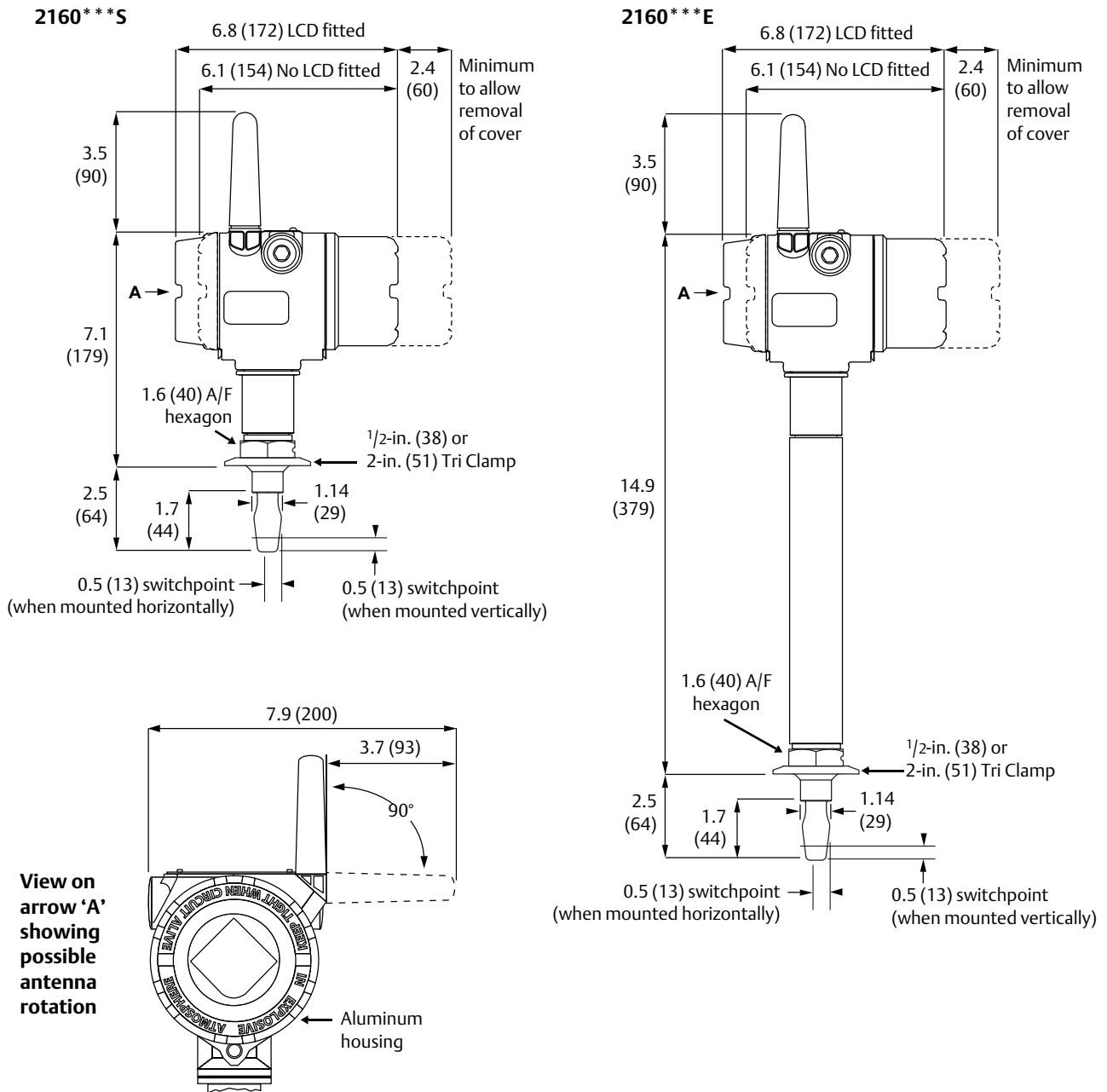

Dimensions are in inches (millimeters).

Figure 8. Tri Clamp Process Connections (Extended Length Fork)

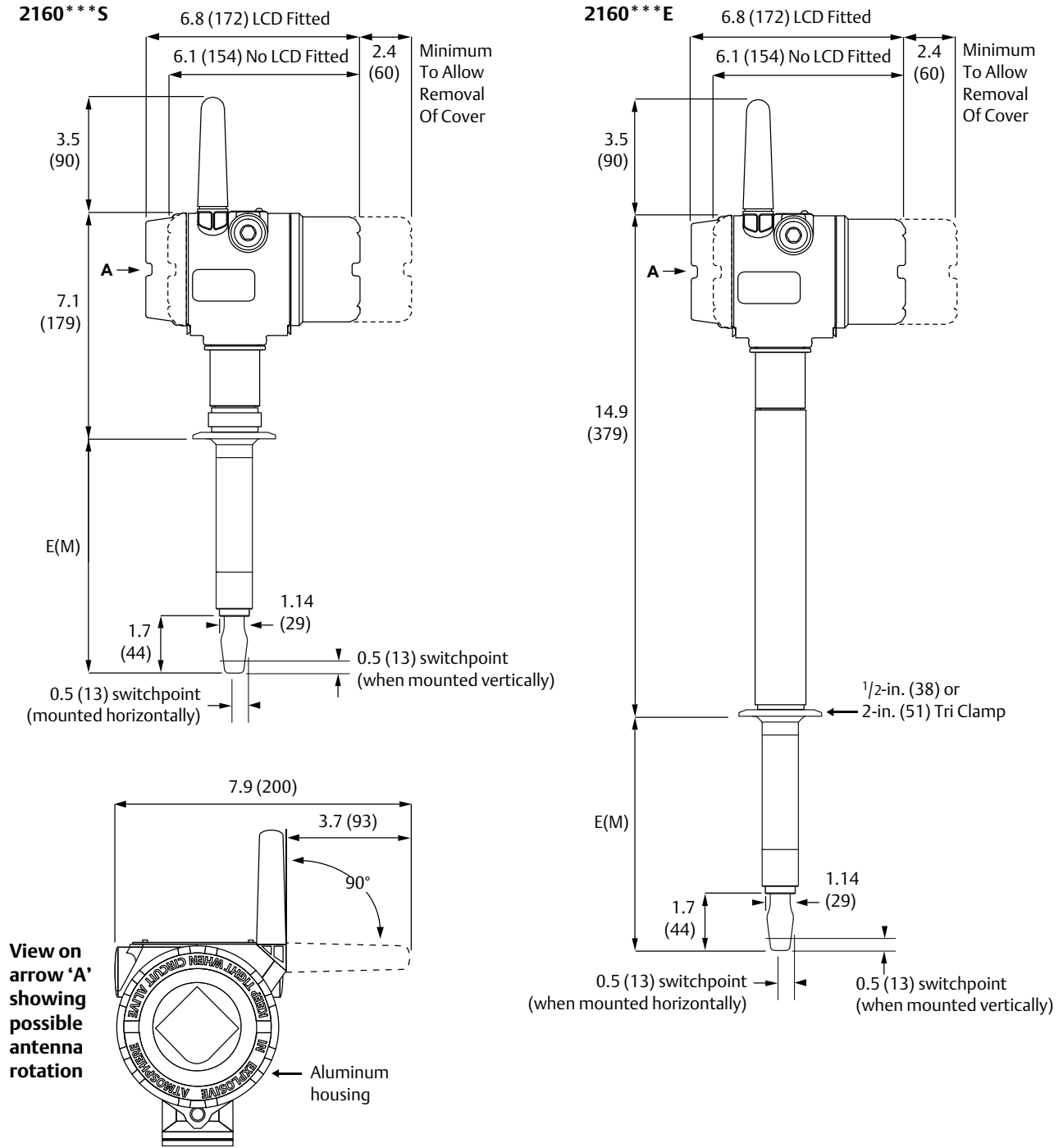

Dimensions are in inches (millimeters).

Table 7. Fork Length for Tri Clamp Rosemount 2160

Process connection	Standard Length Fork Length Code H	Minimum Length Fork Length Code E(M)	Maximum Length Fork Length Code E(M) ⁽¹⁾
Tri Clamp	1.73 in. (44 mm)	4.13 in. (105 mm)	118.1 in. (3000 mm)

1. Maximum extended length of fork with hand-polished option is 39.4 in. (1000 mm).

Global Headquarters

Emerson Automation Solutions

6021 Innovation Blvd.
Shakopee, MN 55379, USA
+1 800 999 9307 or +1 952 906 8888
+1 952 949 7001
RFQ.RMD-RCC@Emerson.com

North America Regional Office

Emerson Automation Solutions

8200 Market Blvd.
Chanhassen, MN 55317, USA
+1 800 999 9307 or +1 952 906 8888
+1 952 949 7001
RMT-NA.RCCRFQ@Emerson.com

Latin America Regional Office

Emerson Automation Solutions

1300 Concord Terrace, Suite 400
Sunrise, FL 33323, USA
+1 954 846 5030
+1 954 846 5121
RFQ.RMD-RCC@Emerson.com

Europe Regional Office

Emerson Automation Solutions Europe GmbH

Neuhofstrasse 19a P.O. Box 1046
CH 6340 Baar
Switzerland
+41 (0) 41 768 6111
+41 (0) 41 768 6300
RFQ.RMD-RCC@Emerson.com

Asia Pacific Regional Office

Emerson Automation Solutions Asia Pacific Pte Ltd

1 Pandan Crescent
Singapore 128461
+65 6777 8211
+65 6777 0947
Enquiries@AP.Emerson.com

Middle East and Africa Regional Office

Emerson Automation Solutions

Emerson FZE P.O. Box 17033
Jebel Ali Free Zone - South 2
Dubai, United Arab Emirates
+971 4 8118100
+971 4 8865465
RFQ.RMTMEA@Emerson.com

 [Linkedin.com/company/Emerson-Automation-Solutions](https://www.linkedin.com/company/Emerson-Automation-Solutions)

 [Twitter.com/Rosemount_News](https://twitter.com/Rosemount_News)

 [Facebook.com/Rosemount](https://www.facebook.com/Rosemount)

 [Youtube.com/user/RosemountMeasurement](https://www.youtube.com/user/RosemountMeasurement)

 [Google.com/+RosemountMeasurement](https://www.google.com/+RosemountMeasurement)

Standard Terms and Conditions of Sale can be found on the www.Emerson.com/en-us//Terms-of-Use
The Emerson logo is a trademark and service mark of Emerson Electric Co. PlantWeb, Rosemount and Rosemount logotype are trademarks of Emerson.
WirelessHART and HART are registered trade marks of FieldComm Group. All other marks are the property of their respective owners.
© 2017 Emerson. All rights reserved.