

200350 and 200355 Accelerometers

Datasheet

Bently Nevada Machinery Condition Monitoring

164804 Rev. N

Description

The 200350 and 200355 Accelerometers are general purpose, case-mounted seismic transducers designed for use with Trendmaster Pro Constant Current Direct Input Card, part number 149811-02 and the Seismic Direct Input Card, part number 164746-01.

The 200350 and 200355 Accelerometers are contained within a hermetically sealed, stainless steel case. The design provides an extremely rugged transducer, well suited for harsh industrial environments. Each transducer's top mounted, 2-pin connector (MIL-C-5015) allows for easy installation and removal of the interconnecting signal cable. A ¼-28 threaded hole on the bottom of the casing accommodates multiple mounting options.

The 200350 and 200355 Accelerometers contain a piezoelectric sensing device, which generates charge when subjected to vibration. This charge is then converted electronically to a differential voltage signal, which is proportional to the acceleration that is parallel to the sensitive axis of the transducer.



If housing measurements are being made for overall protection of the machine, consider the usefulness of the measurement for each application. Most common machine malfunctions (imbalance, misalignment, etc.) originate at the rotor and cause an increase (or at least a change) in rotor vibration. For housing measurements alone to be effective for overall machine protection, a significant amount of rotor vibration must be faithfully transmitted to the bearing housing or machine casing, or more specifically, to the mounting location of the transducer.





In addition, exercise care in the physical installation of the transducer. Improper installation can result in a degradation of the transducer's performance and/or the generation of signals that do not represent actual machine vibration.

Upon request, we can provide engineering services to determine the suitability of housing measurements for the machine in question and/or to provide installation.

Specifications

Parameters are specified from +20 to +30 °C (+68 to +86 °F) and 100 Hz unless otherwise indicated.

 CAUTION	
	Operation outside the specified limits will result in false readings or loss of machine monitoring.



Do not use sensor p/n 200350 for negative excitation voltage (-Vex).

Electrical

	200350	200355
Sensitivity	100 mV/g ±20% (10.2 mV/m/s ² ±20%)	100 mV/g ±5% (10.2 mV/m/s ² ±5%)
Frequency Range (±3 dB)	30-600,000 cpm (0.5-10,000 Hz)	12-600,000 cpm (0.2-10,000 Hz)
Measurement Range	± 50 g	
Transverse	≤ 7%	≤ 5%

Sensitivity		
Amplitude Linearity	± 1%	
Mounted Resonant Frequency	1500 kcpm (25 kHz)	1250 kcpm (20.8 kHz)
Broadband Electrical Noise (1-10kHz)	350 µg (3,434 µm/s ²)	50 µg (491 µm/s ²)
Output Bias Voltage	8 to 12 VDC	
Excitation Voltage	18 to 28 VDC	
Constant Current Excitation	2 to 20 mA	
Settling Time (within 1% of bias)	≤ 2.0 sec	≤ 5.0 sec
Output Impedance	< 150 ohms	< 100 ohms
Discharge Time Constant	≥ 0.3 sec	≥ 0.8 sec
Electrical Isolation (Case)	> 108 ohms	

Environmental

Operating Temperature Range	-65°F to +250 °F (-54°C to +121 °C)
Shock Survivability	5,000 g pk
Relative Humidity	100% relative, condensing, non-submerged
Enclosure Rating	IP68

Physical

	200350	200355
Hex Size	11/16" (18 mm)	7/8" (22mm)
Height	1.65" (42.4 mm)	2.06" (52.3 mm)
Weight	1.8 oz (51 grams)	3.3 oz (94 grams)
Mounting Thread	1/4-28 Female	
Mounting Torque (Maximum)	2 to 5 ft-lb (2.7 to 6.8 N-m)	
Sensing Element	Ceramic	
Sensing Geometry	Shear	

Housing Material	Stainless Steel
Sealing	Welded Hermetic
Electrical Connector	2-Pin Mil-C-5015
Electrical Connection Position	Top

Hazardous Area Approvals



For the detailed listing of country and product specific approvals, refer to the *Approvals Quick Reference Guide* (108M1756) available from Bently.com.

Compliance and Certifications

FCC

This device complies with part 15 of the FCC Rules. Operation is subject to the following two conditions:

- This device may not cause harmful interference.
- This device must accept any interference received, including interference that may cause undesired operation.

EMC

EMC Directive 2014/30/EU

RoHS

RoHS Directive 2011/65/EU

Maritime

330400 and 330425 only

ABS 2009 Steel Vessels Rules

1-1-4/7.7,4-8-3/1.11.1,4-9-7/13

CSA/NRTL/C

177230	<p>Ex nL IIC T4: AEx nA IIC T4: Class I, Div 2, Groups A, B, C, D.</p> <p>Ex ia IIC T4: AEx ia IIC T4: Class I, Div 1, Groups A, B, C, D; Class II, Div 1, Groups E, F, G; Class III, Div 1</p> <p>Install per drawing 177234</p> <p>T4 @ Ta ≤ 80°C</p>
200150, 200155, 200157	<p>Ex ia IIC T4 Class I, Div 1 Groups A,B,C,D</p> <p>T4 @ -40°C ≤ Ta ≤ 80°C Per DWG 167535</p> <p>Ex nL IIC T4 Class I, Div 2 Groups A,B,C,D</p> <p>T4 @ -40°C ≤ Ta ≤ 80°C Per DWG 167535</p>
200350 (Approval Option 1)	
Intrinsically Safe	<p>Ex ia IIC T4 Class I, Division 1, Groups A, B, C and D</p> <p>AEx ia IIC T4 Class I, Division 1, Groups A, B, C and D</p> <p>T4 @ -54 °C ≤ Ta ≤ +121 °C (-65.2 °F ≤ Ta ≤ 249.8 °F) Per drawing 175825</p>
Intrinsically Safe and Non-Incendive	<p>Ex nL IIC T4 Class I, Division 2, Groups A, B, C and D</p> <p>AEx nA T4 Class I, Division 2, Groups A, B, C and D</p> <p>T4 @ -54 °C ≤ Ta ≤ +121 °C (-65.2 °F ≤ Ta ≤ +249.8 °F) per drawing 17582</p>

ATEX/IECEx

Ci=16.2 nF	
Li= 0	

177230

 II 1 G
 Ex ia IIC T4 Ga

 II 3 G
 Ex na IIC T4 Gc

T4@ Ta = -40°C to 80°C

Entity Parameters

Zone 0/1	Zone 2
Ui= 28V	Ui= 28V
Ii= 120mA	Ii= 120mA
Pi= 1W	Pi= 1W
Ci=0	
Li=121.06µh	

**200150, 200155,
 200157**

 II 1 G
 Ex ia IIC T4 Ga

 II 3 G
 Ex na IIC T4 Gc

T4@ Ta = -40°C to 80°C

Entity Parameters

Zone 0/1	Zone 2
Ui= 27V	Ui= 27V
Ii= 150mA	Ii= 150mA
Ci=16.2 nF	
Li= 0	

200350

 II 1 G
 Ex ia IIC T4 Ga

 II 3 G
 Ex na IIC T4 Gc

T4@ Ta = -54°C to +121°C

Entity Parameters

Zone 0/1	Zone 2
Ui= 28V	Ui= 28V
Ii= 200mA	Ii= 200mA
Pi= 1W	Pi= 1W

Hazardous Area Conditions of Safe Use

ATEX/IECEx

Zone 0/1:

Equipment must be connected to equipment, which meets the above listed entity parameters.

The cables type A or B (in compliance with EN 60079-25) must respect the cable parameters listed with the entity parameters.

Zone 2 :

The supply electrical parameters shall not exceed the values mentioned in the tables above.

Ordering Information



For the detailed listing of country and product specific approvals, refer to the *Approvals Quick Reference Guide* (108M1756) available from Bently.com.

200350 Accelerometer

200350 – AA – BB – CC

A: Mounting Stud	
00	¼-28 SS w/ Brass tip, 0.5"
01	¼-28 to M6 x 1.00 Stainless Steel
02	¼-28 to M8 x 1.25 Stainless Steel
09	No mounting stud
10	1/4 -28 Adhesive Stud Mount
11	M6x1 Adhesive Stud Mount
12	M8x1.25 Adhesive Stud Mount
13	Magnetic Base Kit
B: Tolerance	
00	100 mV/g ± 20% (10.2 mV/m/s ² ±20%)
C: Approvals	
00	No Approvals
01	CSA, ATEX, IECEx

200355 Accelerometer

200355 – AA – BB – CC

A: Mounting Stud	
00	¼-28 SS w/ Brass tip, 0.5"
01	¼-28 to M6 x 1.00 BeCu
02	¼-28 to M8 x 1.25 BeCu
09	No mounting stud
10	1/4 - 28 Adhesive Stud Mount
11	M6x1 Adhesive Stud Mount
12	M8x1.25 Adhesive Stud Mount
13	Magnetic Base Kit
B: Tolerance	
00	100 mV/g ± 5% (10.2 mV/m/s ² ±5%)
C: Approvals	
00	No Approvals

Accessories

168303	200350 and 200355 Accelerometer User Guide
162411	Trendmaster Pro System User Guide
149831	Trendmaster DSM Datasheet
149823	Trendmaster DSM User Guide

Mounting Studs

Dimensional diagrams of all available mounting studs are shown in [Graphs and Figures](#)

164373	¼-28 Mounting Stud
164372	M6x1 Mounting Stud
167559	M8X1.25 Mounting Stud

Adhesive Mounting Kits

Adhesive studs are sold in kits containing two threaded studs and two mounting pads. Also in the kit is a packet of acrylic adhesive and materials to mix its two components. A scouring pad and alcohol wipe are provided for preparing the mounting surface.

Temperature Range	-67°F to +250 °F (-55°C to 121 °C)
Cure Time	24 hours

Magnetic Base Kit

The magnetic base has a pull of 35 lbf and it is suitable for placement on both curved surfaces and flat surfaces. The magnet comes supplied with a ¼-28 mounting stud. A dimensional diagram of the magnetic base is shown in [Graphs and Figures](#)

286244	Magnetic Base w/ Mounting Stud
--------	--------------------------------

Cables

The Splash proof cable is not recommended for the model 200350 accelerometer.

The standard cables are 22 AWG 2-conductor twisted shielded pairs with 2-socket moisture-resistant female connector at one end,

terminal lugs at the other end. Cable length is optional and comes in increments of 1 ft between the stated maximum and minimum lengths.

Splash Proof Cable

CB2W100 – AAA

A: Length	
015	15 ft.
032	32 ft.
064	64 ft.
112	112 ft.
125	125 ft.
150	150 ft.
200	200 ft.
250	250 ft.

Standard Cable, No Armor

9571 – AA

A: Length	
02	Minimum length, 2 ft.
99	Maximum length, 99 ft.
XX	Desired length in ft.

The following are standard lengths

Feet	Meters (approx.)
6	1.8
8	2.4
10	3.0
12	3.6
15	4.5
17	5.0
20	6.0
25	7.6
30	9.0
33	10.0
50	15.2
99	30.0

 Non-standard/custom lengths can also be ordered at additional cost

Standard Cable, Armored

84661 – AA

A: Length	
03	Minimum length, 3 ft.
99	Maximum length, 99 ft.
XX	Desired length in ft.

The following are standard lengths

Feet	Meters (approx.)
6	1.8
8	2.4
10	3.0
12	3.6
15	4.5
17	5.0
20	6.0
25	7.6
30	9.0
33	10.0
50	15.2
99	30.0

 Non-standard/custom lengths can also be ordered at additional cost

Graphs and Figures

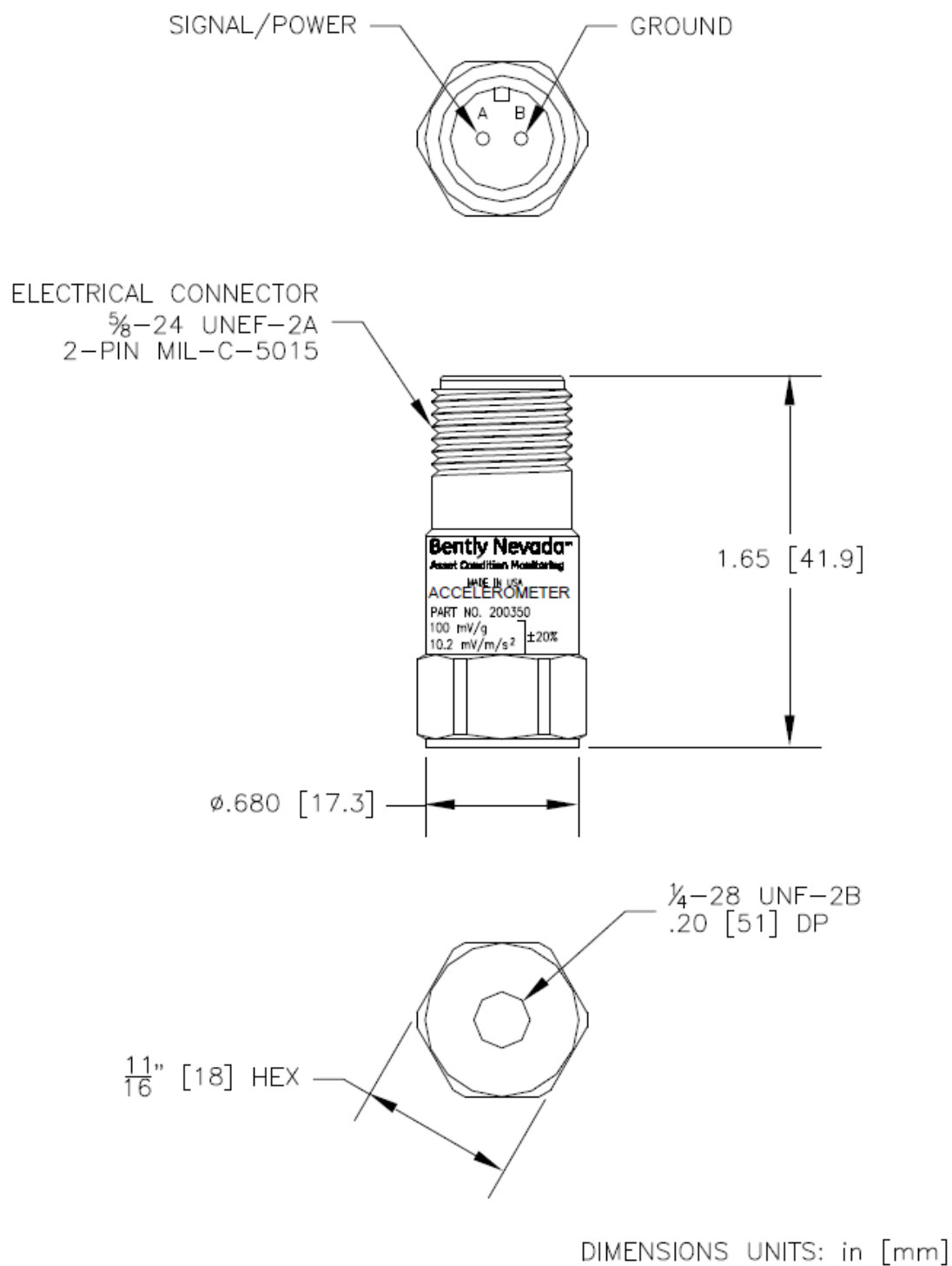
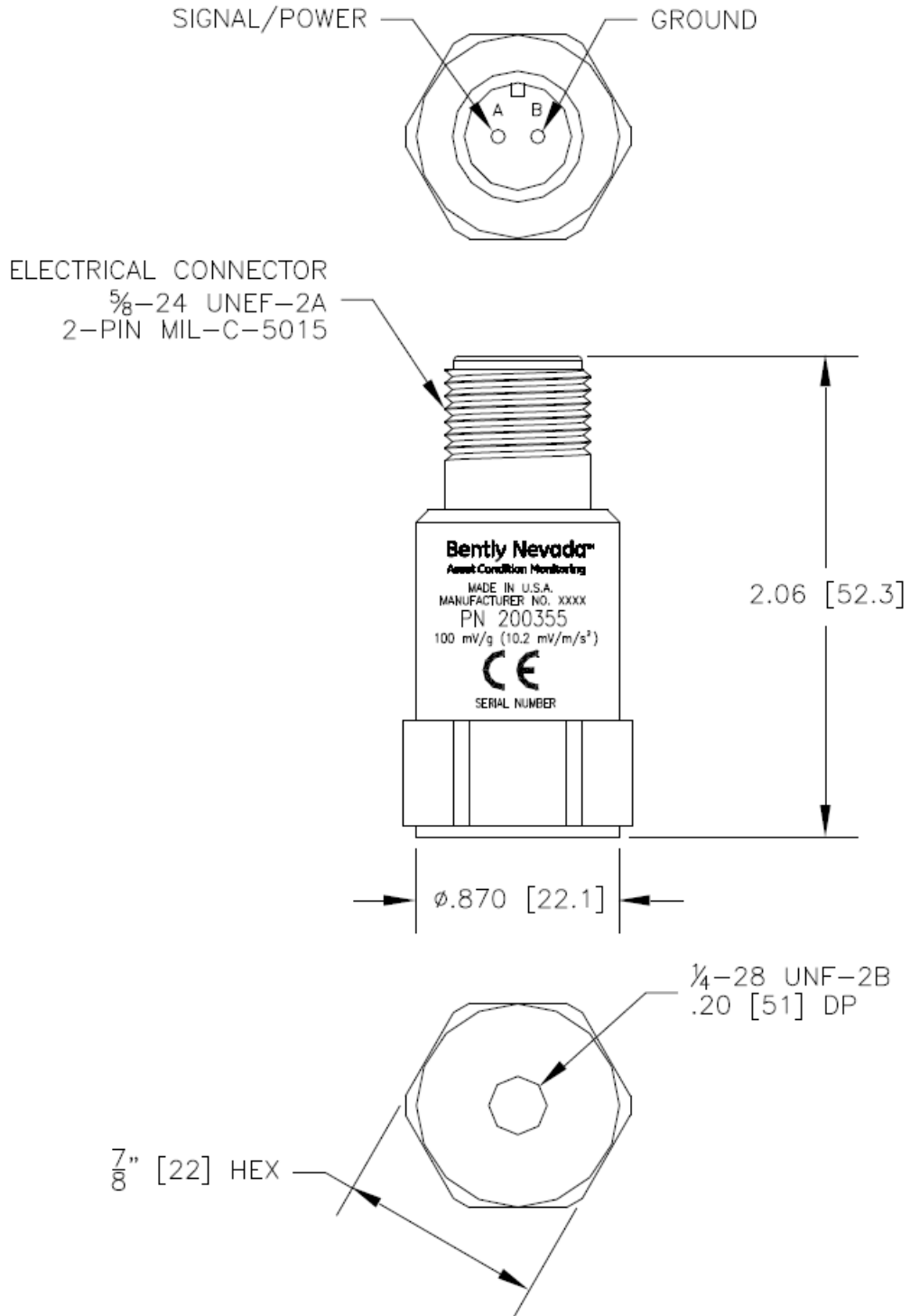

Figure 1: 200350 Accelerometer Dimensional Drawing



DIMENSIONS UNITS: in [mm]

Figure 2: 200355 Accelerometer Dimensional Drawing

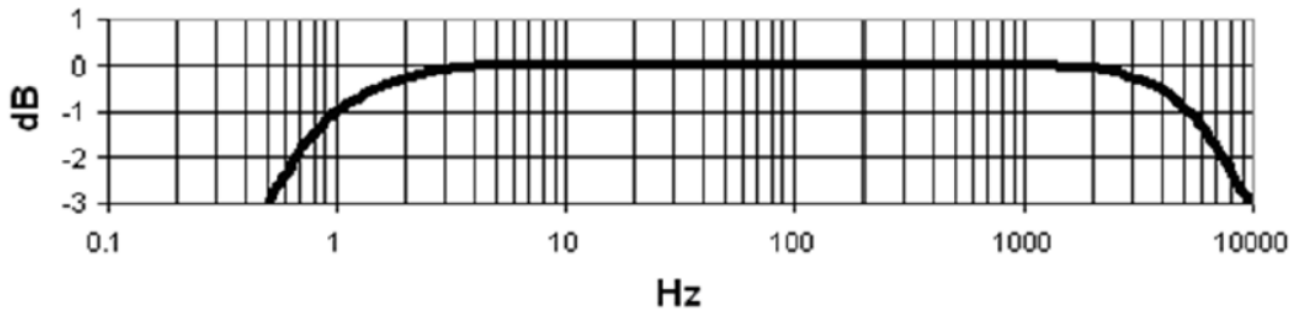

Figure 3: 200350 Accelerometer Frequency Response

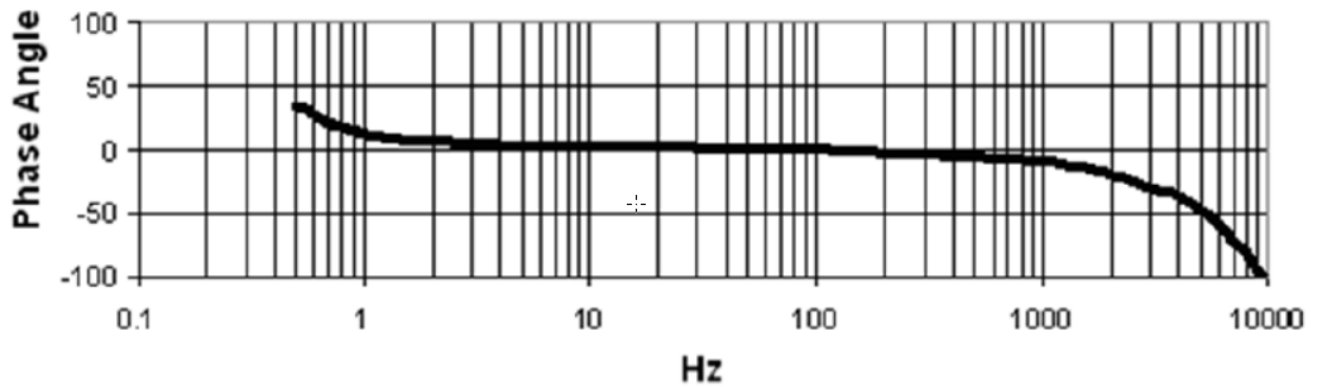

Figure 4: 200350 Accelerometer Phase

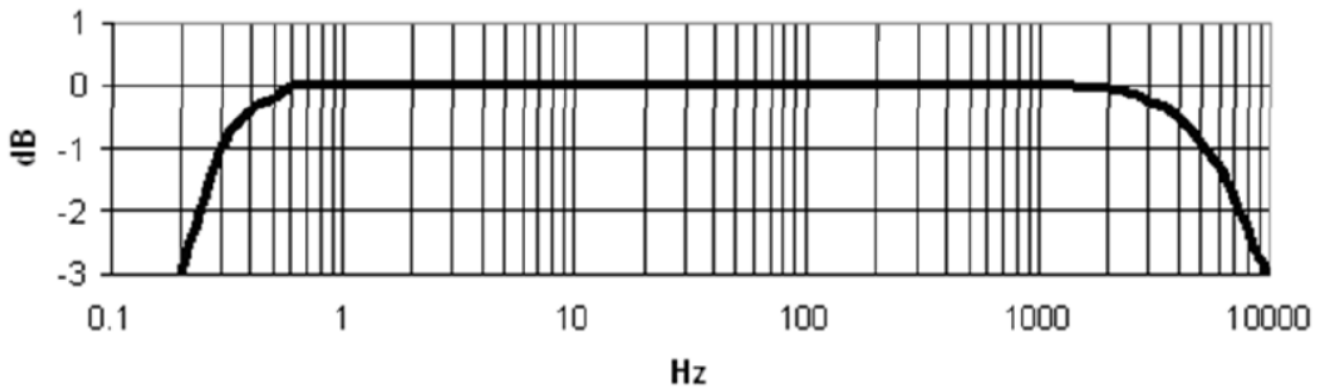

Figure 5: 200355 Accelerometer Frequency Response

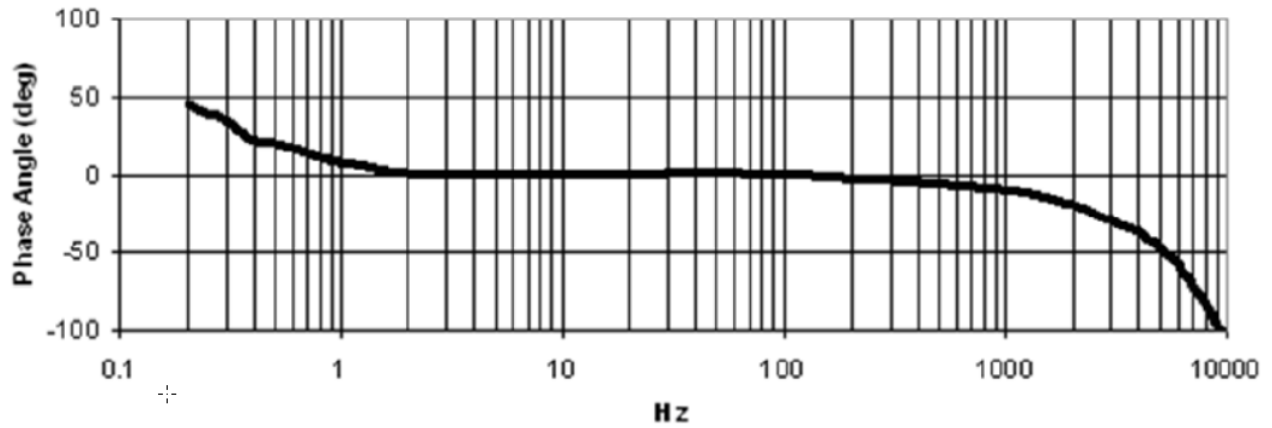

Figure 6: 200355 Accelerometer Phase

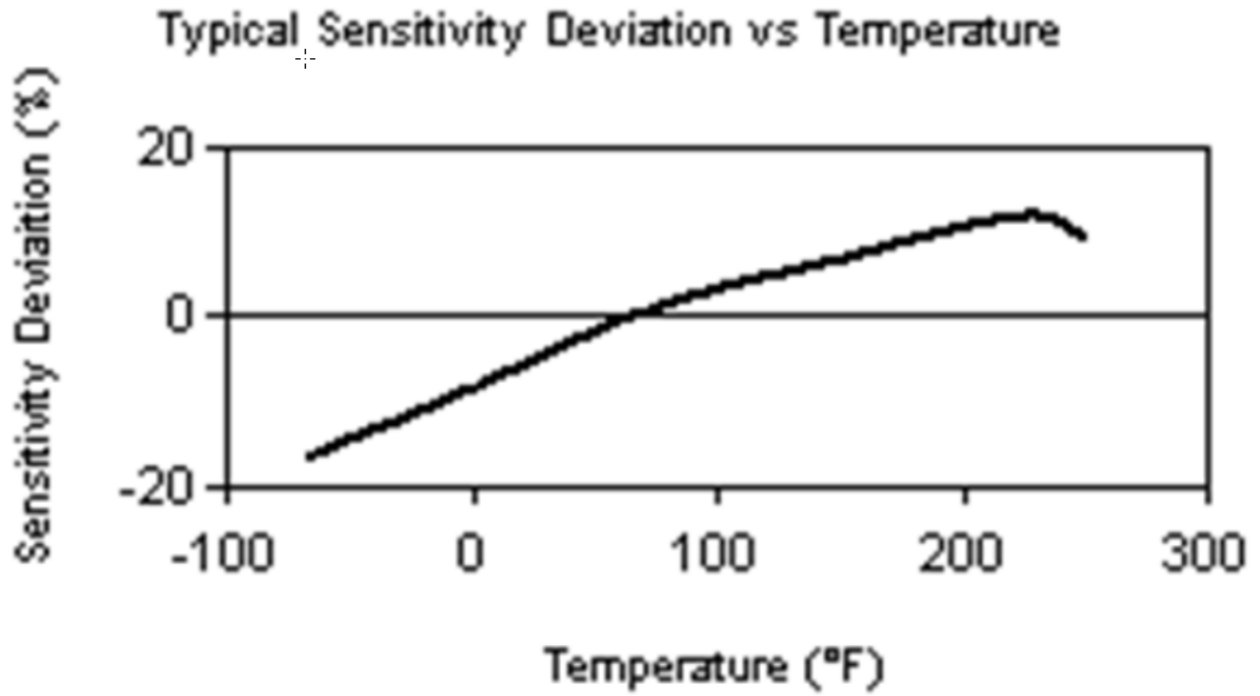

Figure 7: Temperature Sensitivity Curve

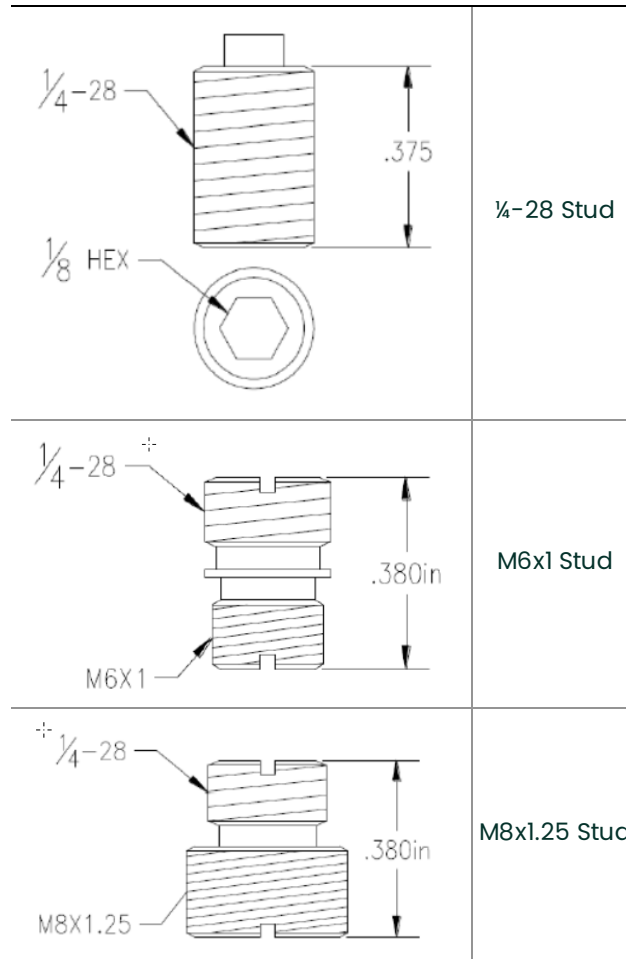

Figure 8: Mounting Stud Dimensional Drawings

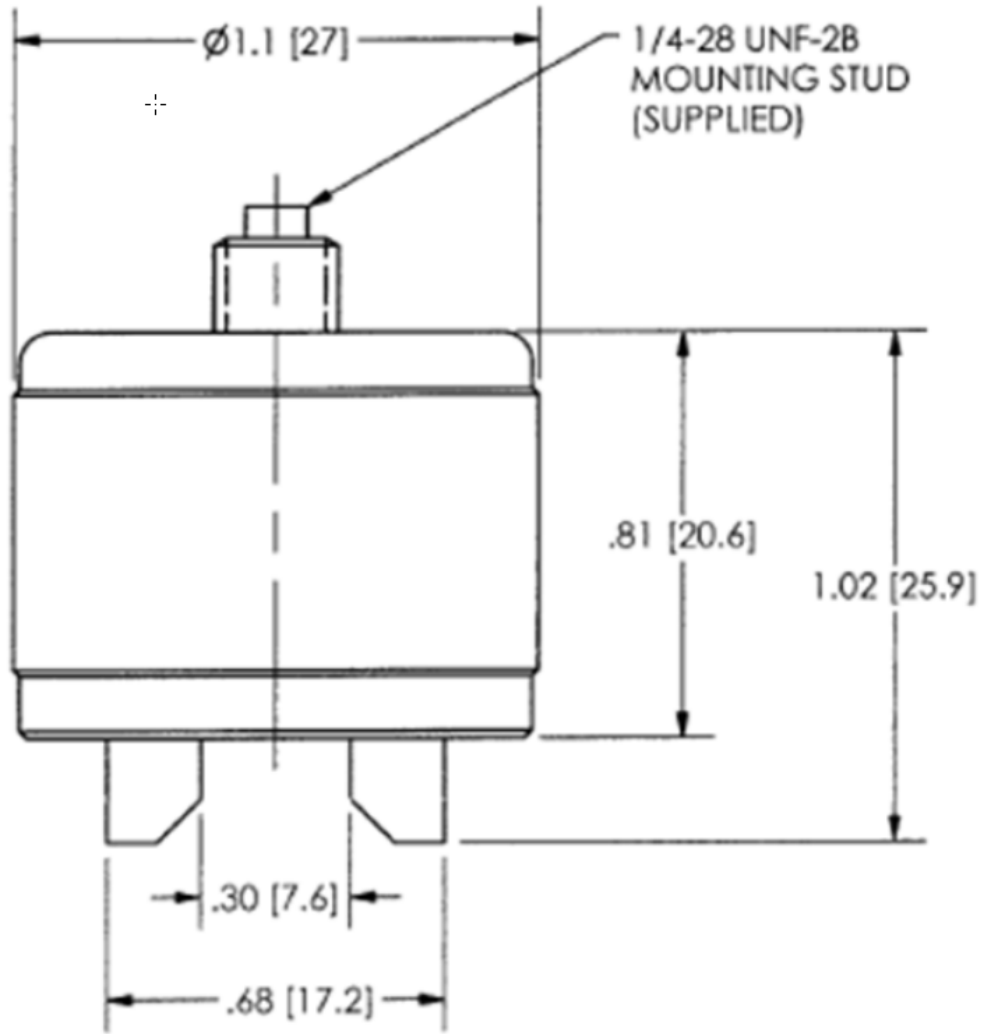

Figure 9: Magnetic Base Dimensional Drawing

Copyright 2020 Baker Hughes Company. All rights reserved.



Bently Nevada and Orbit Logo are registered trademarks of Bently Nevada, a Baker Hughes Business, in the United States and other countries. The Baker Hughes logo is a trademark of Baker Hughes Company. All other product and company names are trademarks of their respective holders. Use of the trademarks does not imply any affiliation with or endorsement by the respective holders.

Baker Hughes provides this information on an "as is" basis for general information purposes. Baker Hughes does not make any representation as to the accuracy or completeness of the information and makes no warranties of any kind, specific, implied or oral, to the fullest extent permissible by law, including those of merchantability and fitness for a particular purpose or use. Baker Hughes hereby disclaims any and all liability for any direct, indirect, consequential or special damages, claims for lost profits, or third party claims arising from the use of the information, whether a claim is asserted in contract, tort, or otherwise. Baker Hughes reserves the right to make changes in specifications and features shown herein, or discontinue the product described at any time without notice or obligation. Contact your Baker Hughes representative for the most current information.

The information contained in this document is the property of Baker Hughes and its affiliates; and is subject to change without prior notice. It is being supplied as a service to our customers and may not be altered or its content repackaged without the express written consent of Baker Hughes. This product or associated products may be covered by one or more patents. See [Bently.com/legal](https://www.bently.com/legal).

1631 Bently Parkway South, Minden, Nevada USA 89423
Phone: 1.775.782.3611 or 1.800.227.5514 (US only)
[Bently.com](https://www.bently.com)