

Emerson™ Smart Wireless Gateway



WirelessHART

- Gateway connects wireless self-organizing networks with any host system
- Easy configuration and management of self-organizing networks
- Easy integration into control systems and data applications through serial and Ethernet LAN connections
- Seamless integration into AMS® Device Manager and DeltaV™ automation system
- Greater than 99% reliability with industry proven security
- Smart Wireless capabilities extends the full benefit of PlantWeb® architecture to previously inaccessible locations

Emerson Smart Wireless Gateway

Gain real-time process information with greater than 99% wireless data reliability

- The Smart Wireless Gateway automatically manages wireless communications in constantly changing environments.
- Native integration with DeltaV and Ovation automation systems provides simple and fast commissioning for wireless field networks.
- Connect to data historians, legacy host systems, and other via a LAN applications through Ethernet, Modbus®, Serial, OPC, EtherNet/IP™, and HART® outputs.



Guarantee system availability with redundant Smart Wireless Gateways

- Never lose the wireless network with hot standby capability and automatic fault detection.
- Smart Wireless Gateways function as a single system, eliminating the need for duplicate host integration.
- One-click configuration and plug-and-play architecture

Complete wireless network configuration tools provided with each Gateway

- The integrated web interface allows easy configuration of the wireless network and data integration without the need to install additional software.
- Complimentary AMS Wireless Configurator software provides Emerson Device Dashboards to configure devices and view diagnostic data.
- Drag and drop device provisioning enables a secure method to add new wireless devices to the wireless field network.



Contents

Emerson’s Smart Wireless Solution	3	Specifications	6
Ordering Information	4	Product Certifications	8
Accessories and spare parts	5	Dimensional Drawings	10

Emerson's Smart Wireless Solution

IEC 62591 (WirelessHART®)... The industry standard

Self-organizing, adaptive mesh routing

- No wireless expertise required, network automatically finds the best communication paths
- The self-organizing, self-healing network manages multiple communication paths for any given device. If an obstruction is introduced into the network, data will continue to flow because the device already has other established paths. The network will then lay in more communication paths as needed for that device.

Reliable wireless architecture

- Standard IEEE 802.15.4 radios
- 2.4 GHz ISM band sliced into 15 radio-channels
- Time Synchronized Channel Hopping to avoid interference from other radios, Wi-Fi, and EMC sources and increase reliability
- Direct sequence spread spectrum (DSSS) technology delivers high reliability in challenging radio environment

Emerson's Smart Wireless

Seamless integration via LAN to all existing host systems

- Native integration into DeltaV and Ovation is transparent and seamless
- Gateways interface with existing host systems via a LAN, using industry standard protocols including OPC, Modbus TCP/IP, Modbus RTU, and EtherNet/IP

Layered security keeps your network safe

- Ensures data transmissions are received only by the Smart Wireless Gateway
- Network devices implement industry standard Encryption, Authentication, Verification, Anti-Jamming, and Key Management
- Third party security verification including Achilles and FIPS197- User based login and enforced password strength. Password strength monitoring, user based log in, password reset requirements, automatic lockout, password expiration requirements. Based on guidelines from ISA99.03.03 standard approved level two.

SmartPower™ solutions

- Optimized Emerson instrumentation, both hardware and software, to extend power module life
- SmartPower technologies enable predictable power life

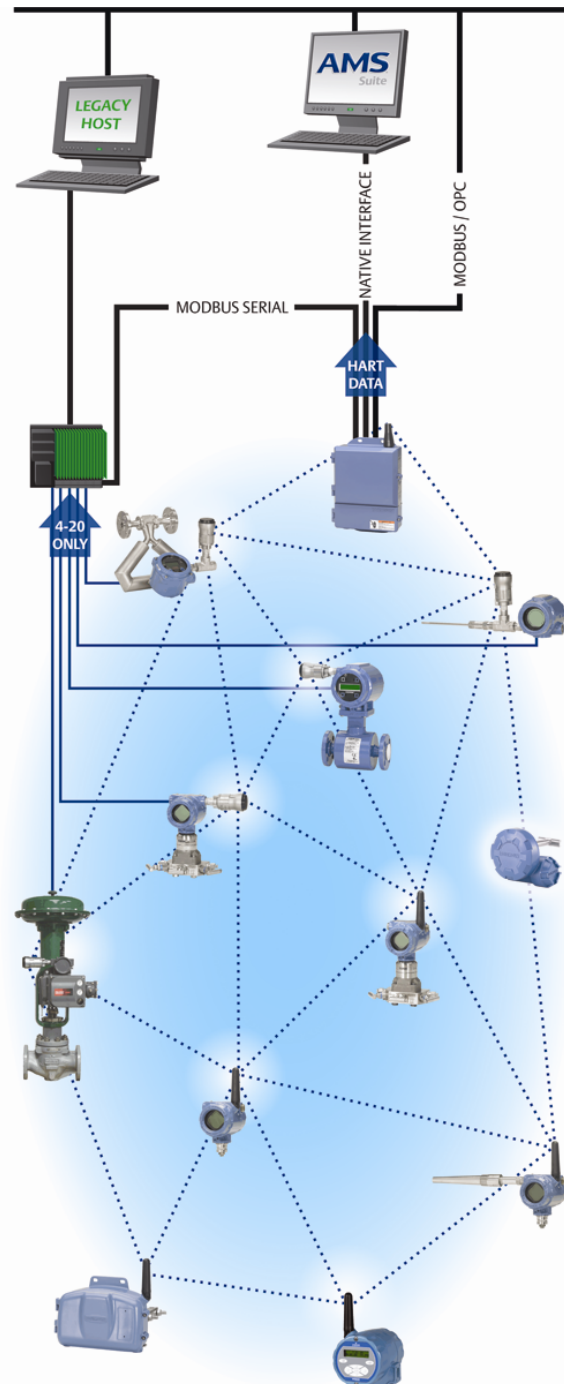

Ordering Information

Specification and selection of product materials, options, or components must be made by the purchaser of the equipment. See [page 6](#) for more information on Material Selection.

Table 1. Smart Wireless Gateway Ordering Information

★ The Standard offering represents the most common options. The starred options (★) should be selected for best delivery.
The Expanded offering is subject to additional delivery lead time.

Model	Product description	
1420	Smart Wireless Gateway	
Power input		
A	24 VDC nominal (10.5-30 VDC)	★
Ethernet communications - physical connection		
1 ⁽¹⁾⁽²⁾	Ethernet	★
2 ⁽³⁾⁽⁴⁾	Dual Ethernet	★
Wireless update rate, operating frequency, and protocol		
A3	User configurable update rate, 2.4 GHz DSSS, <i>WirelessHART</i>	★
Serial communication		
N	None	★
A ⁽⁵⁾	Modbus RTU via RS485	★
Ethernet communication - data protocols		
2	Webserver, Modbus TCP/IP, AMS ready, HART-IP™	★
4	Webserver, Modbus TCP/IP, AMS ready, HART-IP, OPC	★
5 ⁽⁶⁾	DeltaV ready	★
6 ⁽⁶⁾	Ovation ready	★
8	Webserver, EtherNet/IP, AMS ready, HART-IP	★
9	Webserver, EtherNet/IP, Modbus TCP/IP, AMS ready, HART-IP	★

Options (include with selected model number)

Product certifications		
N5	U.S.A. Division 2	★
N6	CSA Division 2, Non-incendive	★
N1 ⁽⁷⁾	ATEX Type n	★
ND ⁽⁷⁾	ATEX Dust	★
N7 ⁽⁷⁾	IECEX Type n	★
NF ⁽⁷⁾	IECEX Dust	★
KD ⁽⁷⁾	FM & CSA Division 2, Non-incendive and ATEX Type n	★
N3 ⁽⁷⁾	China Type n	★
N4 ⁽⁷⁾	TIIS Type n	★
NM	Technical Regulation Customs Union (EAC) Type N	★

Table 1. Smart Wireless Gateway Ordering Information

★ The Standard offering represents the most common options. The starred options (★) should be selected for best delivery.

The Expanded offering is subject to additional delivery lead time.

Redundancy options ⁽⁸⁾⁽⁹⁾⁽¹⁰⁾		
RD	Gateway redundancy	★
Adapters		
J1	CM 20 conduit adapters	★
J2	PG 13.5 conduit adapters	★
J3	³ / ₄ NPT conduit adapters	★
Antenna options ⁽¹¹⁾		
WL2	Remote antenna kit, 50-ft. (15.2 m) cable, lightning arrester	★
WL3	Remote antenna kit, 20-ft. (6.1 m) and 30-ft. (9.1 m) cables, lightning arrester	★
WL4	Remote antenna kit, 10-ft. (3.0 m) and 40-ft. (12.2 m) cables, lightning arrester	★
WN2 ⁽¹²⁾	High-gain, remote antenna kit, 25-ft. (7.6m) cable, lightning arrester	
Typical model number: 1420 A 2 A3 A 2 N5		

1. Single active 10/100 baseT Ethernet port with RJ45 connector.
2. Additional ports disabled.
3. Dual active 10/100 baseT Ethernet ports with RJ45 connectors.
4. Multiple active ports have separate IP addresses, firewall isolation, and no packet forwarding.
5. Convertible to RS232 via adaptor, not included with Gateway.
6. Includes Webserver, Modbus TCP, AMS Ready, HART-IP, and OPC.
7. Options may or may not come with POE. See terminal block configuration for determination if the device is compatible with POE or see the 1420 Manual.
8. Requires the selection of Dual Ethernet option code 2.
9. Not available with DeltaV Ready option code 5.
10. Not available with EtherNet/IP option codes 8 and 9
11. The WL2, WL3, WL4, and WN2 options require minor assembly.
12. Not available in all countries.

Accessories and spare parts

Table 2. Spare Parts

Item description	Part number
Spare kit, WL2 replacement ⁽¹⁾ , remote antenna, 50-ft. (15.2 m) cable, and lightning arrester	01420-1615-0302
Spare kit, WL3 replacement ⁽¹⁾ , remote antenna, 20/30-ft. (6.1/9.1 m) cables, and lightning arrester	01420-1615-0303
Spare kit, WL4 replacement ⁽¹⁾ , remote antenna, 10/40-ft. (3.0/12.2 m) cables, and lightning arrester	01420-1615-0304
Spare kit, WN2 replacement ⁽¹⁾ , high gain, remote antenna, 25-ft. (7.6 m) cable, and lightning arrester ⁽²⁾	01420-1615-0402

1. Can not upgrade from integral to remote antenna.
2. Not available in all countries.

Specifications

Functional specifications

Input power

10.5 - 30 VDC

Current draw

For non-POE enabled Gateways, the operation current draw is based on 3.6 Watts average power consumption.

Momentary startup Current Draw up to twice Operating Current Draw.

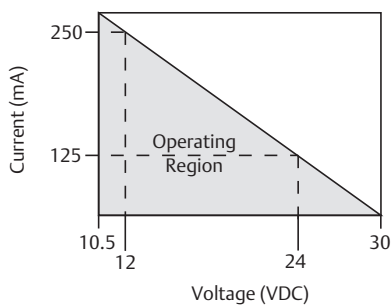

Power and Ethernet

PSE mode

50v - 57 vDC Output 9per IEEE 802.3at-2009)
25.5 W maximum

Radio frequency power output from antenna

Maximum of 10 mW (10 dBm) EIRP
Maximum of 40 mW (16 dBm) EIRP for WN2 High Gain option

Environmental

Operating Temperature Range

-40 to 158 °F (-40 to 70 °C)

Operating Humidity Range

10-90% relative humidity

EMC performance

Complies with EN61326-1:2006.

Antenna options

Integrated Omni-directional Antenna
Optional remote mount Omni-directional Antenna

Physical specifications

Material selection

Emerson provides a variety of Rosemount product with various product options and configurations including materials of construction that can be expected to perform well in a wide range of applications. The Rosemount product information presented is intended as a guide for the purchaser to make an appropriate selection for the application. It is the purchaser's sole responsibility to make a careful analysis of all process parameters (such as all chemical components, temperature, pressure, flow rate, abrasives, contaminants, etc.), when specifying product, materials, options and components for the particular application. Emerson Process Management is not in a position to evaluate or guarantee the compatibility of the process fluid or other process parameters with the product, options, configuration or materials of construction selected.

Weight

10 lb (4.54 kg)

Material of construction

Housing

Low-copper aluminum, NEMA 4X

Paint

Polyurethane

Cover gasket

Silicone Rubber

Antenna

Integrated Antenna: PBT/PC

Remote Antenna: Fiber Glass

Certifications

Class I Division 2 (U.S.)

Equivalent Worldwide

Communication specifications

Isolated RS485

2-wire communication link for Modbus RTU multi drop connections

Baud rate: 57600, 38400, 19200, or 9600

Protocol: Modbus RTU

Wiring: Single twisted shielded pair, 18 AWG. Wiring distance up to 4,000 ft. (1,524 m)

Ethernet

10/100base-TX Ethernet communication port

Protocols: EtherNet/IP Modbus TCP, OPC, HART-IP, HTTPS (for Web Interface)

Wiring: Cat5E shielded cable. Wiring distance 328 ft. (100 m).

Modbus

Supports Modbus RTU and Modbus TCP with 32-bit floating point values, integers, and scaled integers.

Modbus Registers are user-specified.

OPC

OPC server supports OPC DA v2, v3

EtherNet/IP

Supports EtherNet/IP protocol with 32 bit Floating Point values and Integers.

EtherNet/IP Assembly Input-Output instances are user configurable.

EtherNet/IP specifications are managed and distributed by ODVA.

Self-organizing network specifications

Protocol

IEC 62591 (*WirelessHART*), 2.4 - 2.5 GHz DSSS.

Maximum network size

100 wireless devices @ 8 sec or higher.

50 wireless devices @ 4 sec.

25 wireless devices @ 2 sec.

12 wireless devices @ 1 sec.

Supported device update rates

1, 2, 4, 8, 16, 32 seconds or 1 - 60 minutes

Network size/latency

100 Devices: less than 10 sec.

50 Devices: less than 5 sec.

Data reliability

>99%

PoE

Supports IEEE 802.11 PoE as a PD or a PSE on either Port; jumper selectable. PSE ratings: IEEE 802.11af for 12VDC input and IEEE 802.11at for 24VDC input

System security specifications

Ethernet

Secure Sockets Layer (SSL)- enabled (default) TCP/IP communications

Smart Wireless Gateway Access

Role-based Access Control (RBAC) including Administrator, Maintenance, Operator, and Executive. Administrator has complete control of the gateway and connections to host systems and the self-organizing network.

Self-organizing network

AES-128 Encrypted *WirelessHART*, including individual session keys. Drag and drop device provisioning, including unique join keys and white listing.

Internal firewall

User Configurable TCP ports for communications protocols, including Enable/Disable and user specified port numbers. Inspects both incoming and outgoing packets.

Third party certification

Worldtech: Achilles Level 1 certified for network resiliency.

National Institute of Standards and Technology (NIST): Advanced Encryption Standard (AES) Algorithm conforming to Federal Information Processing Standard Publication 197 (FIPS-197)

Product Certifications

Rev 1.1

European Directive Information

A copy of the EC Declaration of Conformity can be found at the end of the Quick Start Guide. The most recent revision of the EC Declaration of Conformity can be found at www.rosemount.com.

Telecommunication Compliance

All wireless devices require certification to ensure that they adhere to regulations regarding the use of the RF spectrum. Nearly every country requires this type of product certification.

Emerson is working with governmental agencies around the world to supply fully compliant products and remove the risk of violating country directives or laws governing wireless device usage.

FCC and IC

This device complies with Part 15 of the FCC Rules. Operation is subject to the following conditions: This device may not cause harmful interference. This device must accept any interference received, including interference that may cause undesired operation. This device must be installed to ensure a minimum antenna separation distance of 20 cm from all persons.

Ordinary Location Certification

As standard, the transmitter has been examined and tested to determine that the design meets the basic electrical, mechanical, and fire protection requirements by a nationally recognized test laboratory (NRTL) as accredited by the Federal Occupational Safety and Health Administration (OSHA).

Installing Equipment in North America

The US National Electrical Code (NEC) and the Canadian Electrical Code (CEC) permit the use of Division marked equipment in Zones and Zone marked equipment in Divisions. The markings must be suitable for the area classification, gas, and temperature class. This information is clearly defined in the respective codes.

USA

- N5** U.S.A. Division 2
 Certificate: CSA 70010780
 Standards: FM Class 3600 - 2011, FM Class 3611 - 2004, FM Class 3616 - 2011, UL 50 - 11th Ed, ANSI/ISA 61010-1 - 2012
 Markings: NI CL 1, DIV 2, GP A, B, C, D T4;
 Suitable for use in CL II, III, DIV 2, GP F, G T4;
 T4(-40 °C ≤ T_a ≤ +60 °C);
 Nonincendive outputs to remote antenna when connected per Rosemount drawing 01420-1011; Type 4X

Special Condition for Safe Use:

1. Explosion Hazard. Do not disconnect equipment when a flammable or combustible atmosphere is present.

Canada

- N6** Canada Division 2
 Certificate: CSA 70010780
 Standards: CAN/CSA C22.2 No. 0-M91 (R2001), CAN/CSA Std C22.2 No. 94-M91 (R2001), CSA Std C22.2 No. 142-M1987, CSA Std C22.2 No. 213-M1987, CSA C22.2 No. 61010-1 – 2012
 Markings: Suitable for Class 1, Division 2, Groups A, B, C, and D, T4; when connected per Rosemount drawing 01420-1011; Type 4X

Special Condition for Safe Use:

1. Explosion Hazard. Do not disconnect equipment when a flammable or combustible atmosphere is present.

Europe

- N1** ATEX Type n
 Certificate: Baseefa07ATEX0056X
 Standards: EN 60079-0: 2012, EN 60079-15: 2010
 Markings:  II 3 G Ex nA IIC T4 Gc,
 T4(-40 °C ≤ T_a ≤ +65 °C), V_{MAX} = 28 Vdc

Special Conditions for Safe Use (X):

1. The equipment is not capable of withstanding the 500V insulation test required by clause 6.5.1 of EN 60079-15:2010. This must be taken into account when installing the3 equipment.
2. The surface resistivity of the antenna is greater than 1GΩ. To avoid electrostatic charge build-up, it must not be rubbed with a dry cloth or cleaned with solvents.

ND ATEX Dust
 Certificate: Baseefa07ATEX0057X
 Standards: EN 60079-0: 2012, EN 60079-31: 2009
 Markings:  II 3 D Ex tc IIIC T135 °C Dc,
 (-40 °C ≤ T_a ≤ +65 °C)

Special Condition for Safe Use (X):

1. The surface resistivity of the antenna is greater than 1GΩ. To avoid electrostatic charge build-up, it must not be rubbed with a dry cloth or cleaned with solvents.

International

N7 IECEx Type n
 Certificate: IECEx BAS 07.0012X
 Standards: IEC 60079-0: 2011, IEC 60079-15: 2010
 Markings: Ex nA IIC T4 Gc, T4(-40 °C ≤ T_a ≤ +65 °C),
 V_{MAX} = 28 Vdc

Special Conditions for Safe Use (X):

1. The apparatus is not capable of withstanding the 500 V electrical strength test as defined in Clause 6.5.1 of IEC 60079-15:2012. This must be taken into account during installation.
2. The surface resistivity of the antenna is greater than 1GΩ. To avoid electrostatic charge build-up, it must not be rubbed with a dry cloth or cleaned with solvents.

NF IECEx Dust
 Certificate: IECEx BAS 07.0013
 Standards: IEC 60079-0: 2011, IEC 60079-31: 2008
 Markings: Ex tc IIIC T135 °C Dc, (-40 °C ≤ T_a ≤ +65 °C)

Special Condition for Safe Use (X):

1. The surface resistivity of the antenna is greater than 1GΩ. To avoid electrostatic charge build-up, it must not be rubbed with a dry cloth or cleaned with solvents.

Brazil

N2 INMETRO Type n
 Certificate: CEPEL 09.1844X
 Standards: ABNT NBR IEC 60079-0:2008,
 IEC 60079-15:2010,
 ABNT NBR IEC 60529:2009;
 Markings: Ex nA nL IIC T4 Gc

Special Condition for Safe Use (X):

1. See certificate for special conditions.

China

N3 China Type n
 Certificate: CNEx13.1929X
 Standards: GB3836.1 – 2010, GB3836.8 - 2003
 Markings: Ex nA nL IIC T4 Gc

Special Condition for Safe Use (X):

1. See certificate for special conditions.

Japan

N4 TIIS Type n
 Certificate: T64855
 Markings: Ex nA nL IIC T4

EAC – Belarus, Kazakhstan, Russia

NM Technical Regulation Customs Union (EAC) Type n
 Certificate: RU C-US.ГБ05.B.00578
 Markings: 2Ex nA IIC T4 X;
 T4(-40 °C ≤ T_a ≤ +65 °C)
 IP66;

Combinations

KD Combination of N1, N5, and N6

Dimensional Drawings

Figure 1. Smart Wireless Gateway

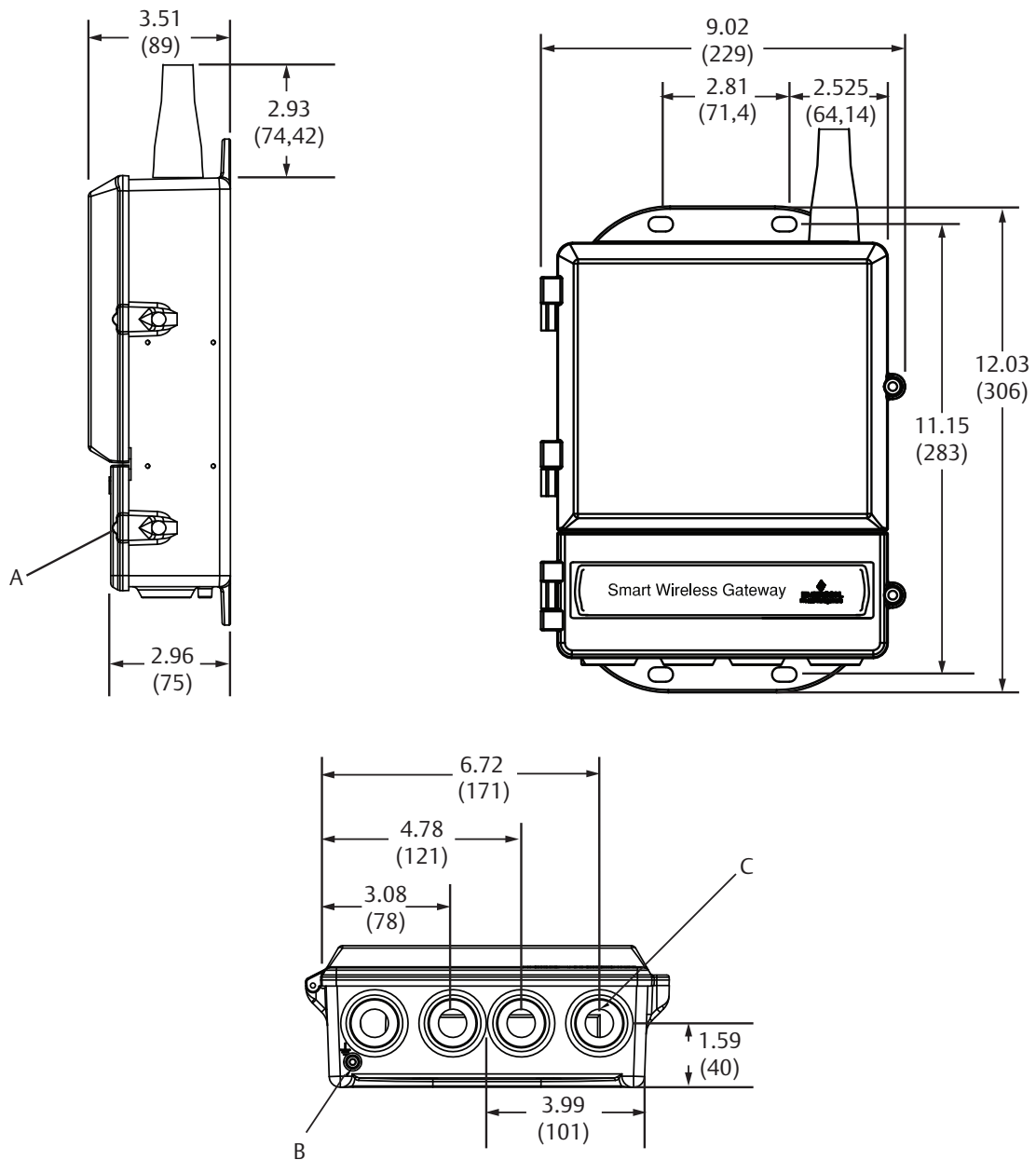

- A. Lower cover (remove for electrical connections)
- B. Ground lug
- C. 1/2-in. NPT conduit connection (4 places)

Dimensions are in inches (millimeters).

Figure 2. Remote Antenna Kit

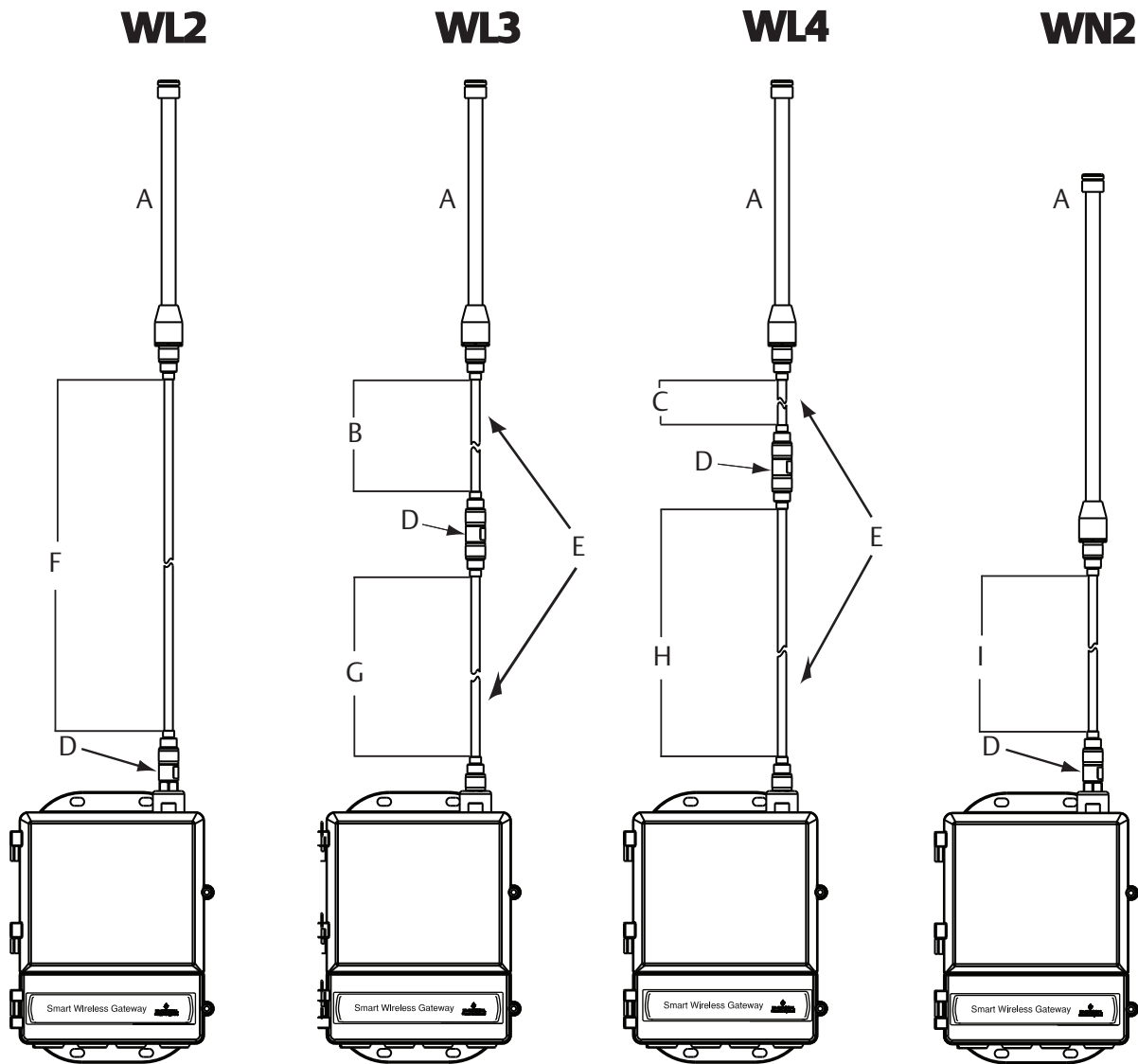

- A. Antenna
- B. 20-ft. (6,1 m) cable
- C. 10-ft. (3,0 m) cable
- D. Lightning arrestor
- E. Interchangeable cables

- F. 50-ft. (15,2 m) cable
- G. 30-ft. (9,1 m) cable
- H. 40-ft. (12,2 m) cable
- I. 25-ft. (7,6 m) cable

The Remote Antenna kit includes sealant tape for remote antenna connection, as well as mounting brackets for the antenna, Lightning Arrestor, and the Smart Wireless Gateway.

Lightning protection is included on all the options.

Note

The cables lengths on the remote antenna options WL3 and WL4 are interchangeable for installation convenience.

Global Headquarters

Emerson Process Management

6021 Innovation Blvd.

Shakopee, MN 55379, USA

+1 800 999 9307 or +1 952 906 8888

+1 952 949 7001

RFQ.RMD-RCC@EmersonProcess.com

North America Regional Office

Emerson Process Management

8200 Market Blvd.

Chanhassen, MN 55317, USA

+1 800 999 9307 or +1 952 906 8888

+1 952 949 7001

RMT-NA.RCCRFQ@Emerson.com

Latin America Regional Office

Emerson Process Management

1300 Concord Terrace, Suite 400

Sunrise, Florida, 33323, USA

+1 954 846 5030

+1 954 846 5121

RFQ.RMD-RCC@EmersonProcess.com

Europe Regional Office

Emerson Process Management Europe GmbH

Neuhofstrasse 19a P.O. Box 1046

CH 6340 Baar

Switzerland

+41 (0) 41 768 6111

+41 (0) 41 768 6300

RFQ.RMD-RCC@EmersonProcess.com

Asia Pacific Regional Office

Emerson Process Management Asia Pacific Pte Ltd

1 Pandan Crescent

Singapore 128461

+65 6777 8211

+65 6777 0947

Enquiries@AP.EmersonProcess.com

Middle East and Africa Regional Office

Emerson Process Management

Emerson FZE P.O. Box 17033,

Jebel Ali Free Zone - South 2

Dubai, United Arab Emirates

+971 4 8118100

+971 4 8865465

RFQ.RMTMEA@Emerson.com

Standard Terms and Conditions of Sale can be found at:
www.rosemount.com/terms_of_sale.

The Emerson logo is a trademark and service mark of Emerson Electric Co.

AMS is a registered trademark of Emerson Electric Co.

Rosemount and Rosemount logotype are registered trademarks of Rosemount Inc.

SmartPower is a trademark of Rosemount Inc.

PlantWeb and DeltaV are registered trademarks of one of the Emerson Process Management group of companies.

HART and *Wireless*HART are registered trademarks of FieldComm Group.

HART-IP is a trademark of the FieldComm Group.

EtherNet/IP is a trademark of ControlNet International under license by ODVA.

Modbus is a registered trademark of Modicon, Inc.

All other marks are the property of their respective owners.

© 2015 Rosemount Inc. All rights reserved.