

Model 1151 Alphaline[®] Pressure Transmitters

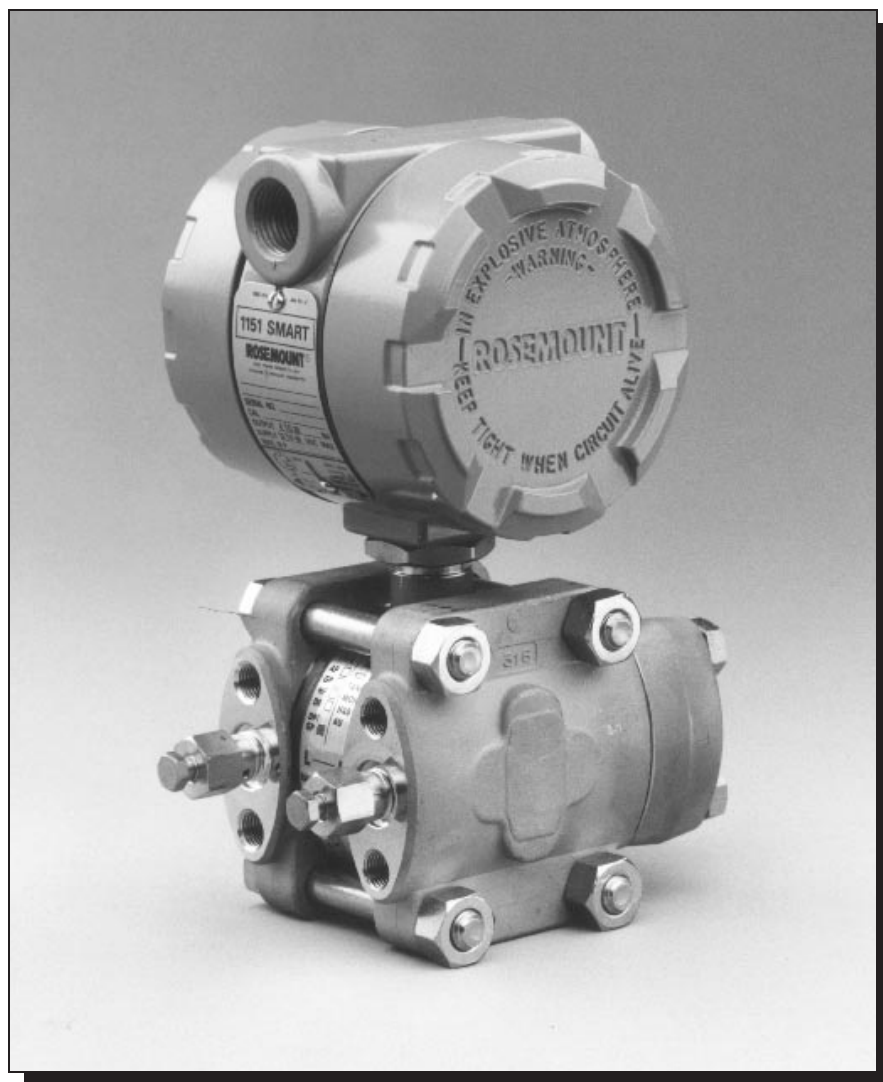

ROSEMOUNT[®]

FISHER-ROSEMOUNT™ Managing The Process Better.™

Model 1151 Alphaline[®] Pressure Transmitters

NOTICE

Read this manual before working with the product. For personal and system safety, and for optimum product performance, make sure you thoroughly understand the contents before installing, using, or maintaining this product.

Within the United States, Rosemount Inc. has two toll-free assistance numbers.

Customer Central: 1-800-999-9307 (7:00 a.m. to 7:00 p.m. CST)
Technical support, quoting, and order-related questions.

North American Response Center: 1-800-654-7768 (24 hours a day – Includes Canada)
Equipment service needs.

For equipment service or support needs outside the United States, contact your local Rosemount representative.

⚠ CAUTION

The products described in this document are NOT designed for nuclear-qualified applications.

Using non-nuclear qualified products in applications that require nuclear-qualified hardware or products may cause inaccurate readings.

For information on Rosemount nuclear-qualified products, contact your local Rosemount Sales Representative.

SNF-0004

May be protected by one or more of the following U.S. Patent Nos. 3,195,028; 3,271,669; 3,318,153; 3,618,390; 3,646,538; 3,793,885; 3,800,413; 3,854,039; 3,859,594; 3,975,719; 4,339,750; 5,237,285; Re. 30,603. May Depend on Model. Other U.S. and Foreign Patents Issued and Pending.

Rosemount, the Rosemount logotype, Alphaline, and SMART FAMILY are registered trademarks of Rosemount Inc.

HART is a registered trademark of the HART Communication Foundation.

δ-Cell is a trademark of Rosemount Inc.

Hastelloy, Hastelloy C, and Hastelloy C-276 are registered trademarks of Cabot Corp.

Monel is a registered trademark of International Nickel Co.

Teflon is a registered trademark of E.I. du Pont de Nemours & Co.

Aflas is a registered trademark of Asahi Glass Co., Ltd.

Kynar is a trademark of Pennwalt Inc.

Fluorolube is a registered trademark of Hooker Chemical Co.

Loctite is a registered trademark of Loctite Corporation.

Cover Photo: 1151-001AB

CE Fisher-Rosemount satisfies all obligations coming from legislation to harmonize product requirements in the European Union.

Rosemount Inc.
8200 Market Boulevard
Chanhassen, MN 55317 USA
Tel 1-800-999-9307
Telex 4310012
Fax (612) 949-7001
© 1997 Rosemount, Inc.



<http://www.rosemount.com>

ROSEMOUNT[®]

FISHER-ROSEMOUNT™ Managing The Process Better.™



Table of Contents

Introduction	Using This Manua.	9
	Model 1151 Alphasine® Pressure Transmitters	9
	Transmitter overview	10
Installation	General Considerations	11
	Mechanical Considerations.	11
	Environmental Requirements	13
	Access Requirements	13
	Process Flange Orientation	13
	Housing Rotation	13
	Terminal Side of Electronics Housing	13
	Circuit Side of Electronics Housing	13
	Exterior of Electronics Housing	13
	Mounting Effects.	14
	Process Connections	14
	Mounting Brackets.	15
	Mounting Requirements (for Steam, Liquid, Gas)	17
	Taps	17
	Drain/Vent Valves	17
	Impulse Piping	18
	Electrical Considerations	18
	Wiring	19
	Conduit Sealing	20
	Power Supply	20
	Grounding	22
	Signal Wiring	22
	Transmitter Case	22
	Grounding Effects	22
	Hazardous Locations Certifications.	24
	Liquid Level Measurement	24
	Open Vessels	24
Closed Vessels	24	
Dry Leg Condition	24	
Wet Leg Condition	25	
Bubbler System in Open Vessel	26	
Calibration	Quick Calibration Procedure (for E, G, and J Electronics).	29
	Quick Calibration Procedure (For L and M Electronics)	29
	Data Flow with Calibration Options	31
	Span Adjustment Range	32
	Zero Adjustment Range	32
	Zero and Span Adjustment	34
	Elevated or Suppressed Zeros	35
	Linearity Adjustment	35
	Damping Adjustment	36
	Static Pressure Span Correction Factor	37

Options	Mounting Brackets 39 (Option Codes B1–B7 and B9) 39 Analog Meters (4–20 ma only) 41 LCD Meters (4–20 ma only) 41 LCD Meter Configuration 41 Remove the Cove 42 Position the Decimal Point and Select the Meter Function 42 Store the Information. 43 Set the Display Equivalent to a 4 mA Signal 43 Set the Display Equivalent to a 20 mA Signal. 43 Replace the Cover. 43 LCD Meter Assembly 43 LCD Meter Specifications 44 Terminal Blocks. 45 Filter Terminal Block (Option Code R2) 46 Transient Protection and Filter Terminal Block (Option Code R1) 46 Retrofitable Transient Terminal Block(Option Code R9) . . . 46 R9 Terminal Block Installation 47 Terminal Block Specifications (for R1, R2, and R9) 49
Maintenance and Troubleshooting	Hardware Diagnostics. 51 Transmitter Disassembly 54 54 Process Sensor Body Removal 55 Removing the Sensor from the Electrical Housing 56 Sensor Module Checkout 57 Reassembly Procedure 58 Preliminary Precaution 58 Connecting the Electrical Housing to the Sensor. 58 Backup Ring and O-ring Installation 58 Optional Plug-in Meter. 60 Return of Material 60
Specifications and Reference Data	Functional Specifications 61 Performance Specifications. 66 Physical Specifications (Standard Configuration). 68

Introduction

USING THIS MANUAL

This manual is designed to assist in installing, operating, and maintaining the Rosemount Model 1151 Analog Pressure Transmitter Family.

Section 2 Installation

provides mechanical and electrical installation instructions.

Section 3 Calibration

explains technique for calibration of the device.

Section 4 Options

explains the options available for the Model 1151, including mounting brackets, LCD meters, custom configuration, transient protection, and filter terminal blocks.

Section 5 Maintenance and Troubleshooting

describes trim procedures and offers troubleshooting instructions for dealing with potential mechanical or electrical difficulties.

Section 6 Specifications and Reference Data

lists functional, performance, and physical specifications data as well as ordering information for the transmitter.

Appendix A Approval Drawings

contains approval drawings for Canadian Standards Association (CSA) and Factory Mutual (FM) intrinsic safety drawings.

Glossary

provides brief definitions of the terms used in this manual and tells where to find more information.

Index

contains a comprehensive, standard index.

MODEL 1151 ALPHALINE® PRESSURE TRANSMITTERS

This manual describes the following Model 1151 Alphaline® Pressure Transmitters.

- **Model 1151DP**— Differential Pressure Transmitter measures differential pressure from 6 inH₂O to 1,000 psi (1.493 to 6895 kPa).
- **Model 1151HP**— Differential Pressure Transmitter for High Line Pressures measures high line pressures from 25 inH₂O to 300 psi (6.22 to 2668 kPa).
- **Model 1151GP**— Gage Pressure Transmitter measures gage pressure from 6 inH₂O to 6,000 psi (1.493 to 41369 kPa).
- **Model 1151AP**— Absolute Pressure Transmitter measures absolute pressure from 25 inH₂O to 1,000 psi (6.22 to 6895 kPa).

TRANSMITTER OVERVIEW

The Rosemount Model 1151 Alphaline® series of pressure transmitters has set an industry standard as the largest-selling transmitter in the world. It brings true precision to the measurement of flow, level, gage and absolute pressures, vacuum, and specific gravity.

With proven performance, quality, and reliability, the Model 1151 provides accurate measurement using the variable capacitance principle. It is virtually unaffected by changes in temperature, static pressure, vibration, and power supply voltage.

Installation, calibration, and commissioning are simplified by the transmitter's compact design, integral junction box, and local span and zero adjustments. Its modular design and high degree of interchangeability result in a minimal investment for spare parts.

Installation

This section covers areas to consider when installing the Model 1151 Analog Transmitter:

- General Considerations
- Mechanical Considerations
- Environmental Requirements
- Electrical Considerations
- Liquid Level Measurement

GENERAL CONSIDERATIONS

The accuracy of a flow, pressure, or level measurement depends on proper installation of the transmitter and impulse piping. The piping between the process and transmitter must accurately transmit process pressure to the transmitter. Mount the transmitter close to the process and use a minimum of piping to achieve best accuracy. Keep in mind, however, the need for easy access, safety of personnel, practical field calibration, and a suitable transmitter environment. In general, install the transmitter so as to minimize vibration, shock, and temperature fluctuations.

Installations in food, beverage, and pharmaceutical processes may require sanitary seals and fittings. Regulations may dictate special installation requirements needed to maintain sanitation and cleanability considerations. See Product Data Sheet 00813-0100-4016 for more information about sanitary pressure instruments from Rosemount Inc.

MECHANICAL CONSIDERATIONS

Rosemount Model 1151DP, GP, HP, and AP transmitters may be mounted in several ways. They may be panel-mounted, wall-mounted, or attached to a 2-inch pipe through an optional mounting bracket. Figure 2-1 shows the transmitter dimensions. The following paragraphs discuss factors necessary for a successful transmitter installation.

Model 1151 Alphasine® Pressure Transmitters

FIGURE 2-1. Dimensional Drawing for Model 1151 Transmitter.

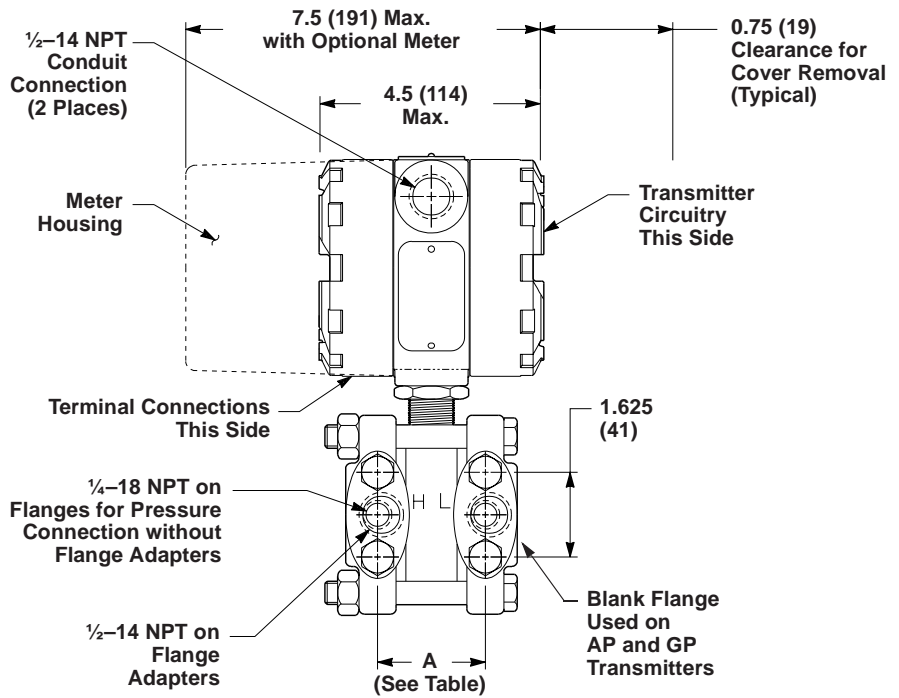

Range	Flange Distance "A" Center to Center	
	inches	mm
3, 4, 5	2.125	54
6, 7	2.188	56
8	2.250	57
9	2.281	58
0	2.328	59

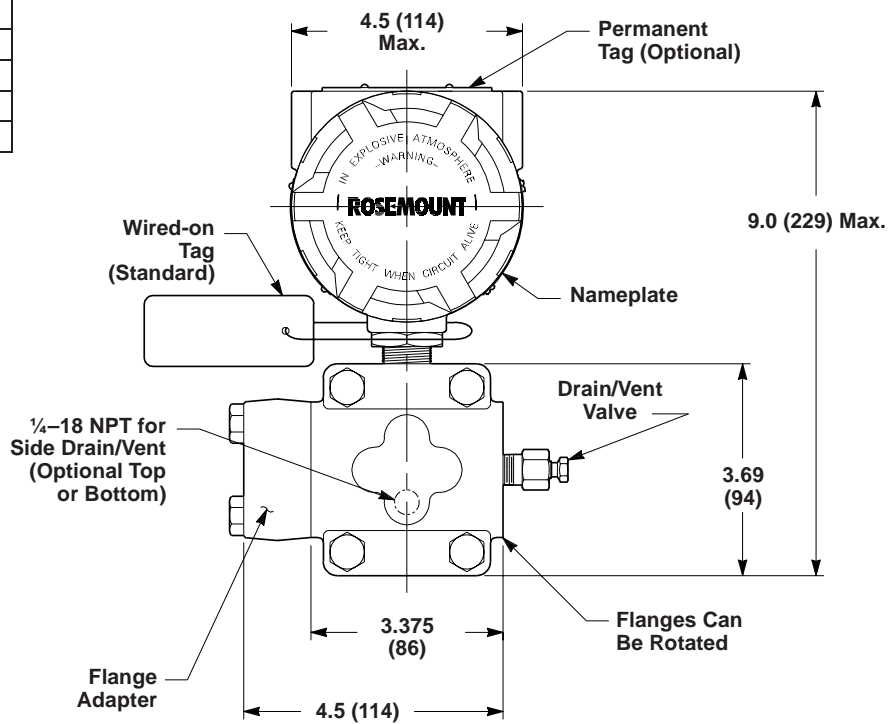

NOTE
Dimensions are in inches (millimeters).

1151-1151A, B05A

ENVIRONMENTAL REQUIREMENTS

Mount the transmitter to minimize ambient temperature changes. The transmitter electronics temperature operating limits are -40 to 200 °F (-40 to 85 °C) for “E” output options, -20 to 150 °F (-29 to 66 °C) for “J” output options, and -20 to 200 °F (-29 to 93 °C) for G, L, and M output options. **Section 5 Maintenance and Troubleshooting** lists the sensing element operating limits. Mount the transmitter to avoid vibration and mechanical shock, and to avoid external contact with corrosive materials.

Access Requirements

When choosing an installation location and position, take into account the need for access to the transmitter.

Process Flange Orientation

Orient the process flanges to enable process connections to be made. For safety reasons, orient the drain/vent valves so that process fluid is directed down and away from technicians when the valves are used. This can be accomplished by pointing the hole in the outside valve body downward and away. In addition, consider the need for a testing or calibration input.

⚠ CAUTION

Do not rotate the transmitter housing more than 90 degrees without disconnecting the header board. Exceeding 90 degrees rotation will damage the internal sensor module wiring. Refer to **Removing the Sensor from the Electrical Housing** on page 5-6 for further information.

Housing Rotation

The electronics housing may be rotated up to 90 degrees to improve field access to the two housing compartments. To rotate the housing less than 90 degrees, loosen the housing lock nut and turn the housing not more than 90 degrees from the orientation shown in Figure 2-1. To rotate the housing more than 90 degrees, follow the transmitter disassembly procedures in **Section 5 Maintenance and Troubleshooting**.

Terminal Side of Electronics Housing

Make wiring connections through the conduit openings on the top side of the housing. The terminal side of the housing is marked on the nameplate located on the side of the transmitter. Mount the transmitter so that the terminal side is accessible. A $\frac{3}{4}$ -inch clearance is required for cover removal with no meter. A 3-inch clearance is required for cover removal if a meter is installed. If practical, provide approximately 6 inches clearance so that a meter may be installed later.

Circuit Side of Electronics Housing

The circuit compartment should not routinely need to be opened when the unit is in service; however, provide 6 inches clearance if possible to allow access for on-site maintenance. The circuit side of the housing is marked on the nameplate located on the side of the transmitter.

Exterior of Electronics Housing

The analog Model 1151 uses local span and zero screws, which are located under the nameplate on the side of the transmitter. Please allow 6 inches clearance if possible to allow access for on-site maintenance.

Mounting Effects

The analog Model 1151 weighs 12 lb (5.4 kg) for AP, DP, GP, and HP transmitters, excluding options. This weight must be securely supported; see Figure 2-2 on page 2-6 for mounting bracket information. The transmitter is calibrated in an upright position at the factory. If this orientation is changed during mounting, the zero point will shift by an amount equivalent to the liquid head caused by the mounting position. **Zero and Span Adjustment** on page 3-6 describes how to correct this shift.

WARNING

Process leaks can cause death or serious injury. Only use bolts supplied with the transmitter or sold by Rosemount Inc. as a spare part. Using unauthorized bolts may reduce pressure retaining capabilities and render the instrument dangerous.

CAUTION

Do not plug the low side with a solid plug. Plugging the low side will cause an output shift.

Process Connections

Model 1151AP, DP, GP, and HP process connections on the transmitter flanges are ¼–18 NPT. Flange adapter unions with ½–14 NPT connections are supplied as standard. These are Class 2 threads; use plant-approved lubricant or sealant when making the process connections. The flange adapters allow users to disconnect from the process by removing the flange adapter bolts. Figure 2-1 on page 2-2 shows the distance between pressure connections. This distance may be varied $\pm 1/8$ inch (3.2 mm) by rotating one or both of the flange adapters.

To ensure a tight seal on the flange adapters or three-valve manifold, first finger-tighten both bolts, then wrench-tighten the first bolt to approximately 29 ft-lbs (34 Nm). Wrench-tighten the second bolt to approximately 29 ft-lbs (34 Nm).

⚠ WARNING

Process leaks can cause death or serious injury. Install and tighten all four flange bolts before applying pressure, or process leakage may result. When properly installed, the flange bolts will protrude through the top of the module housing. Attempting to remove the flange bolts while the transmitter is in service may cause process fluid leaks.

⚠ WARNING

Failure to install flange adapter O-rings can cause process leaks, which can result in death or serious injury.

There are two styles of Rosemount flange adapters, each requiring a unique O-ring, as shown below. Each flange adapter is distinguished by its unique groove.

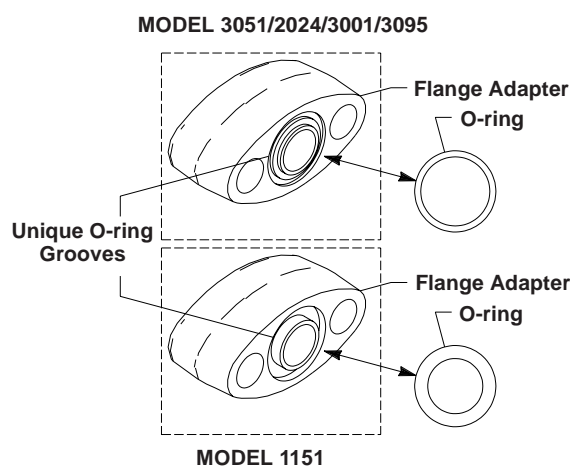

Use only the O-ring designed to seal with the corresponding flange adapter.

Refer to the Spare Parts List on page 6-13 for the part numbers of the flange adapters and O-rings designed for the Model 1151 Pressure Transmitter.

NOTE

If Teflon O-rings are used, they should be replaced if the flange adapter is removed.

The low-side process flange has a $\frac{1}{4}$ -18 NPT connection. A flange adapter union is supplied for $\frac{1}{2}$ -14 NPT process connections. The flange adapter allows the transmitter to be easily disconnected from the process by removing the flange adapter bolts. On open vessels the low-side process flange is open to atmosphere and should be mounted with the threaded hole pointed down. On closed vessels this connection is used for the dry or wet leg.

Mounting Brackets

An optional mounting bracket permits mounting the transmitter to a wall, a panel, or a 2-inch horizontal or vertical pipe. Figure 2-2 illustrates some typical configurations using these mounting brackets.

FIGURE 2-2. Mounting Bracket Options.

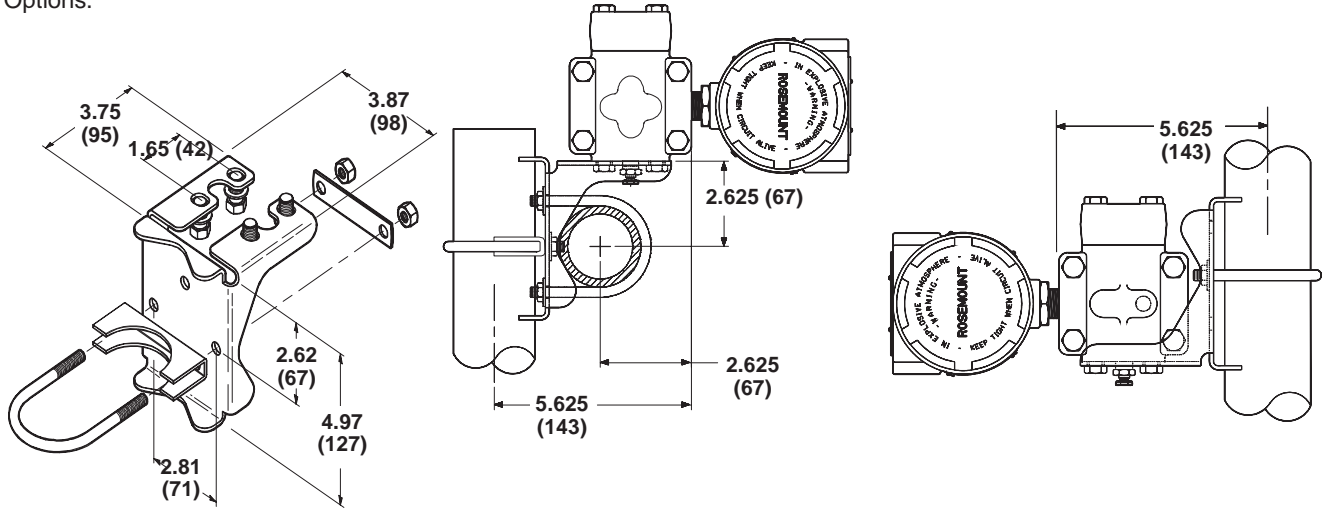

PIPE MOUNTING BRACKET OPTION CODES B1, B4, AND B7

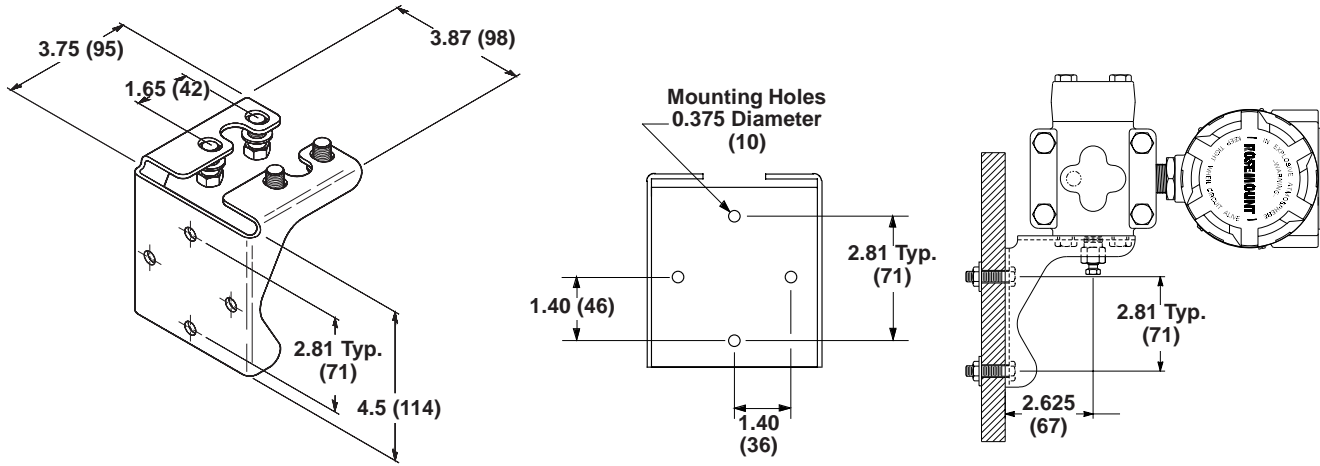

PANEL MOUNTING BRACKET OPTION CODES B2 AND B5

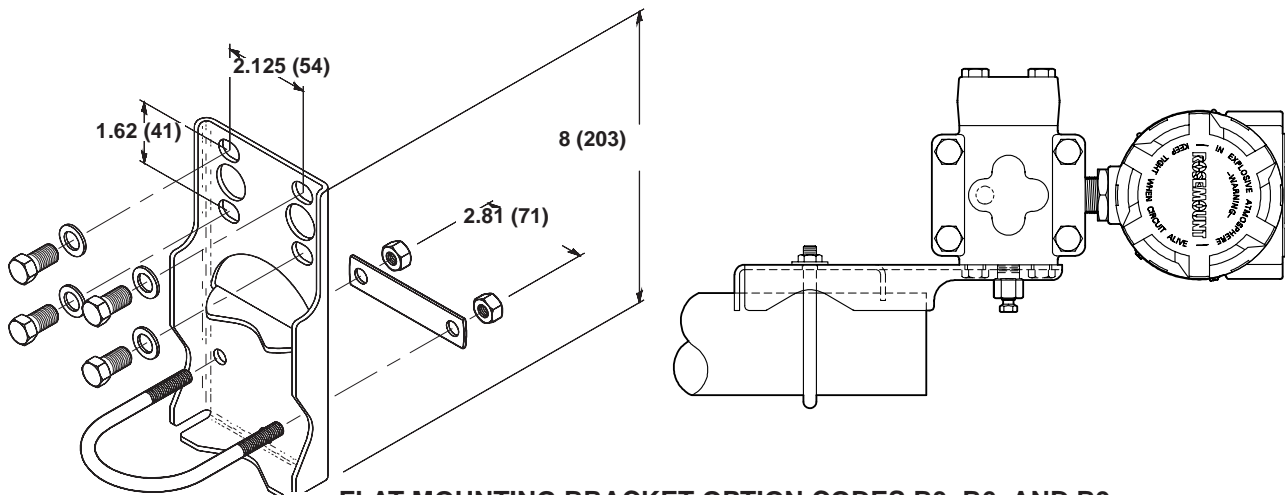

FLAT MOUNTING BRACKET OPTION CODES B3, B6, AND B9

NOTE
Dimensions are in inches (millimeters).

3051-3051D19A, 1151-1151D,B06C

3051-3051B19A, 1151-0244A, 1151-1151E06A

3051-3051H19B, 1151-1151F06B

Mounting Requirements (for Steam, Liquid, Gas)

Taps

The following information applies to steam, liquid, and gas installations.

Different measurement conditions call for different piping configurations. For liquid flow measurement, place taps to the side of the line to prevent sediment deposits, and mount the transmitter beside or below these taps so gases can vent into the process line. For gas flow measurement, place taps in the top or side of the line and mount the transmitter beside or above the taps so liquid will drain into the process line. For steam flow measurement, place taps to the side of the line with the transmitter mounted below them to ensure that the impulse piping stays filled with condensate. See Figure 2-3 for a diagram of these arrangements.

FIGURE 2-3. Steam, Liquid, and Gas Service Installation Diagrams.

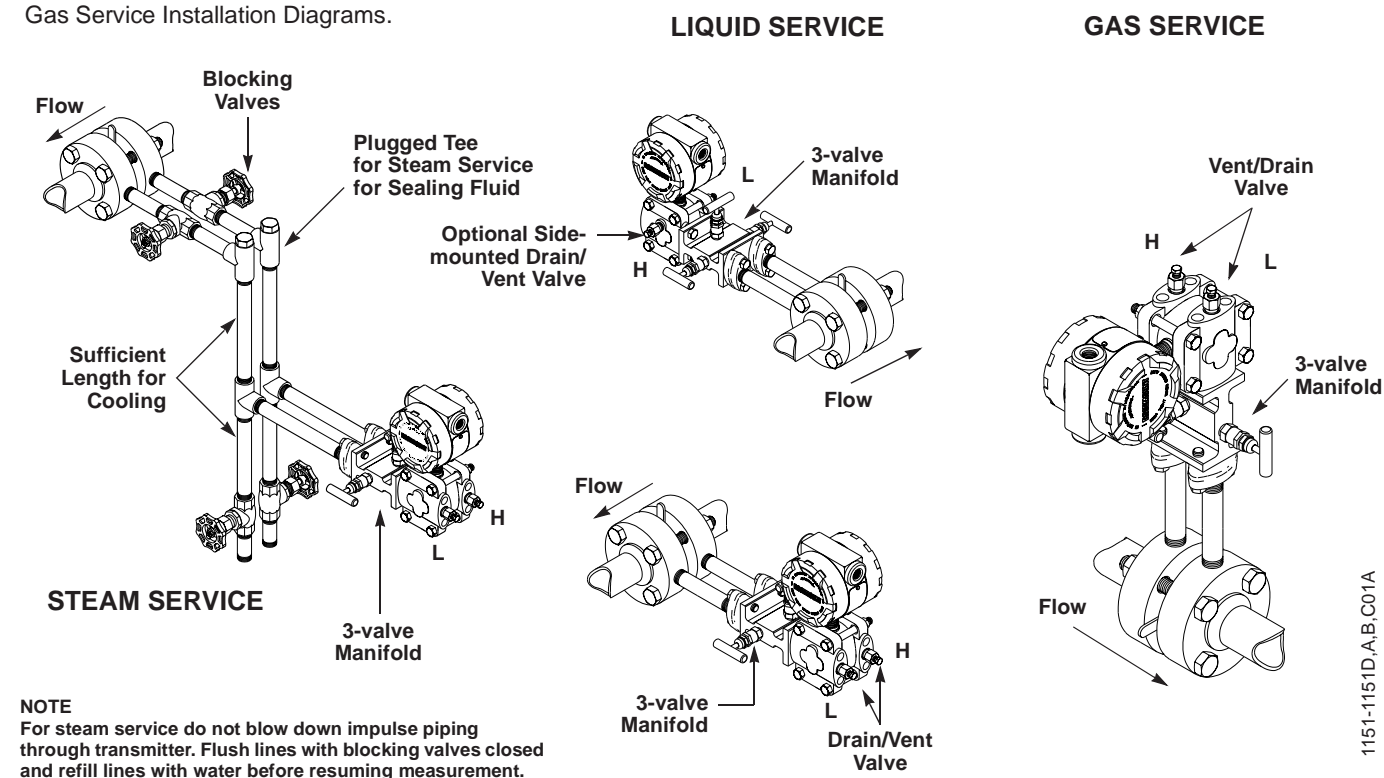

Drain/Vent Valves

For transmitters with side drain/vent valves, place taps to the side of the line. For liquid service, mount the side drain/vent valve upward to allow the gases to vent. For gas service, mount the drain/vent valve down to allow any accumulated liquid to drain. To change the drain/vent valve orientation from top to bottom, rotate the process flange 180 degrees.

CAUTION

Steam or other elevated temperature processes can cause damage to the sensor. Do not allow the temperature inside the process flanges to exceed the transmitter limit of 220 °F (104 °C).

In steam service, lines should be filled with water to prevent contact of the live steam with the transmitter.

Impulse Piping

The piping between the process and the transmitter must accurately transfer the pressure in order to obtain accurate measurements. In this pressure transfer, there are five possible sources of error: leaks, friction loss (particularly if purging is used), trapped gas in a liquid line, liquid in a gas line, and temperature-induced or other density variation between the legs.

The best location for the transmitter in relation to the process pipe depends on the process itself. Consider the following general guidelines in determining transmitter location and placement of impulse piping:

- Keep impulse piping as short as possible.
- Slope the impulse piping at least 1 inch per foot (8 centimeters per meter) upward from the transmitter toward the process connection for liquid.
- Slope the impulse piping at least 1 inch per foot (8 centimeters per meter) downward from the transmitter toward the process connection for gas.
- Avoid high points in liquid lines and low points in gas lines.
- Make sure both impulse legs are the same temperature.
- Use impulse piping large enough to avoid friction effects and prevent blockage.
- Vent all gas from liquid piping legs.
- When using a sealing fluid, fill both piping legs to the same level.
- When purging is necessary, make the purge connection close to the process taps and purge through equal lengths of the same size pipe. Avoid purging through the transmitter.
- Keep corrosive or hot process material out of direct contact with the sensor module and flanges.
- Prevent sediment deposits in the impulse piping.
- Keep the liquid head balanced on both legs of the impulse piping.

ELECTRICAL CONSIDERATIONS

Before making any electrical connections to the Model 1151 analog, consider the following standards and be sure to have proper power supply, conduit, and other accessories. Make sure all electrical installation is in accordance with national and local code requirements, such as the NEC (NFPA 70).

WARNING

Explosions can cause death or serious injury. Do not remove the instrument cover in explosive atmospheres when the circuit is alive.

CAUTION

Do not connect the power signal wiring to the test terminals. Voltage may burn out the reverse-polarity protection diode in the test connection. If the test diode is destroyed, then the transmitter can still be operated without local indication by jumping the test terminals.

CAUTION

High voltage (greater than 55 Volts for “E” electronics, 85 Volts for “G” electronics, 12 Volts for “L” electronics, and 14 Volts for “M” electronics.) can cause damage to the transmitter. Do not apply high voltage to the test terminals.

Wiring

The signal terminals and test terminals are located in a compartment of the electronics housing separate from the transmitter electronics. The nameplate on the side of the transmitter indicates the locations of the terminal and electronics compartments. The upper pair of terminals are the signal terminals and the lower pair are the test terminals. The test terminals have the same 4–20 mA output as the signal terminals and are only for use with the optional integral meter or for testing.

To make connections, remove the cover on the side marked “Terminal” on the nameplate. All power to the transmitter is supplied over the signal wiring. Connect the lead that originates at the positive side of the power supply to the terminal marked “+” and the lead that originates at the negative side of the power supply to the terminal marked “-” as shown in Figure 2-4. No additional wiring is required.

Shielded cable should be used for best results in electrically noisy environments.

FIGURE 2-4. Terminal Connections.

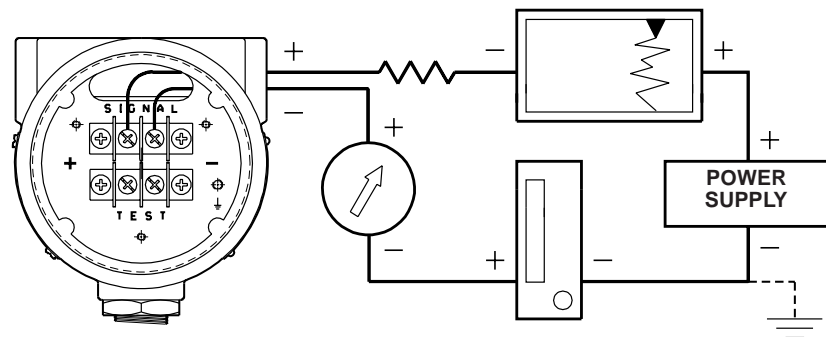

The signal loop may be grounded at any point or left ungrounded.

1151-1151G05A

FIGURE 2-5. Wiring Connections for Low Power Output Codes L and M.

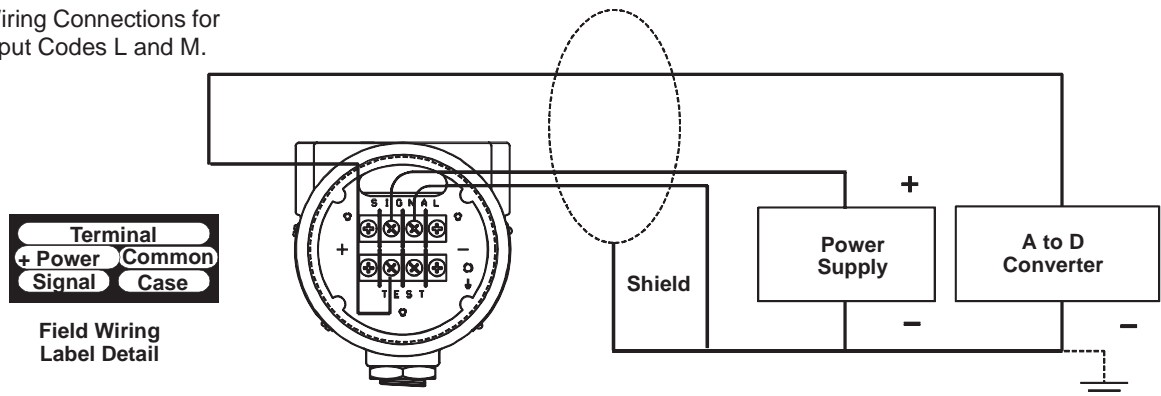

1151-1151H05A

NOTE

An alternate location to connect an ammeter is on the set of terminals labelled “TEST.” Connect the positive lead of the ammeter to the positive test terminal, and the negative lead of the ammeter to the negative test terminal.

NOTE

When conduit lines are used, signal wiring need not be shielded, but twisted pairs should be used for best results. Wiring should be 12-24 AWG.

Conduit Sealing

The 1151 has been rated as “Factory Sealed” by Factory Mutual (FM) and Canadian Standards Association (CSA). It is therefore not necessary to install conduit seals near the transmitter enclosure.

Do not run signal wiring in conduit or open trays with power wiring, or near heavy electrical equipment. Signal wiring may be grounded at any one point on the signal loop, or it may be left ungrounded. The negative terminal of the power supply is a recommended grounding point. The transmitter case must be grounded through the process or conduit connections.

Power Supply

The dc power supply should provide power with less than 2 percent ripple. The total resistance load is the sum of the resistance of the signal leads and the load resistance of the controller, indicator, and related pieces. Note that the resistance of intrinsic safety barriers, if used, must be included.

To power the loop, connect the leads at the set of terminal screws labeled “Signal.” Figure 2-6 illustrates power supply load limitations for the transmitter:

FIGURE 2-6. Power Supply Load Limitations.

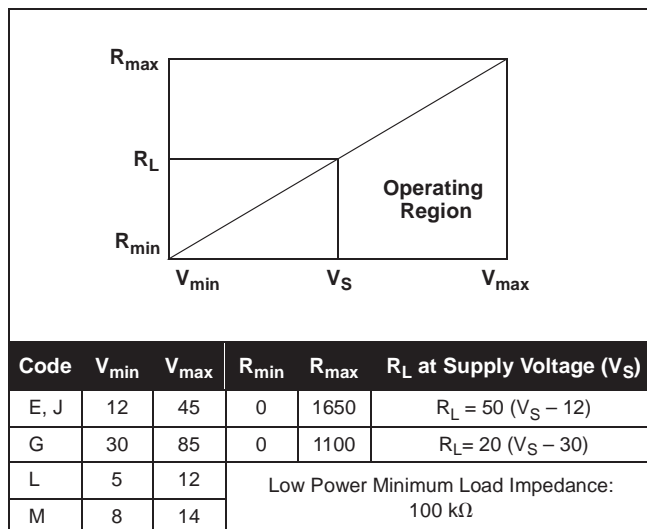

NOTE

For CSA Approvals (codes E and J), V_{max} = 42.4 V dc.

FIGURE 2-7. Conduit Installation Diagrams.

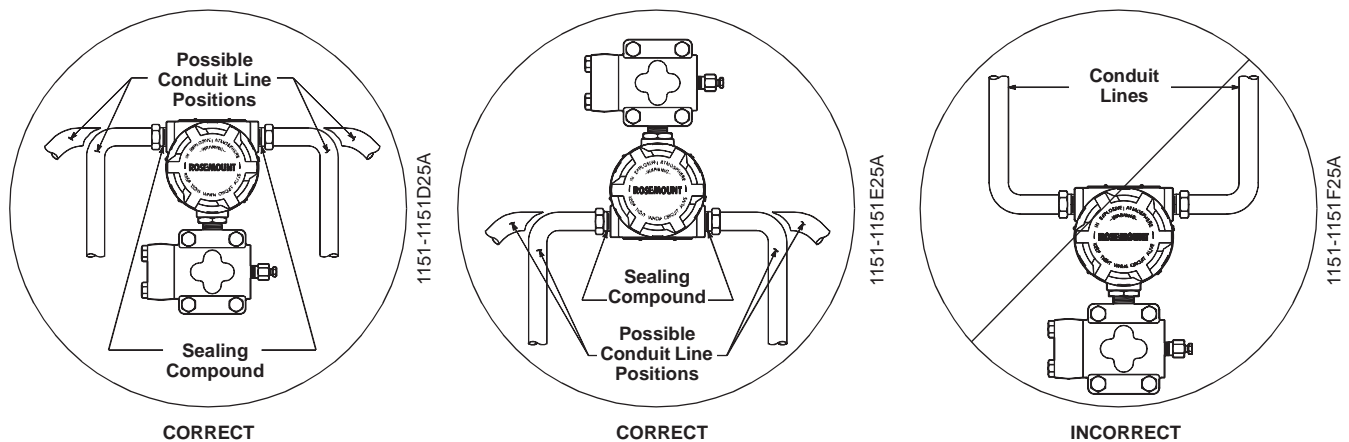

Unused conduit connections on the transmitter housing should be plugged and sealed to avoid moisture accumulation in the terminal side of the housing. The recommended connections of conduit are shown in Figure 2-7.

⚠ WARNING

All explosion proof, flameproof, and dust-ignition proof installations require insertion of conduit plugs in all unused openings with a minimum of 40 ft-lbs (54 N-m) of torque. This will maintain five full threads of engagement.

⚠ CAUTION

If all connections are not sealed, excess moisture accumulation can damage the transmitter. Make sure to mount the transmitter with the electrical housing positioned downward for drainage. To avoid moisture accumulation in the housing, install wiring with a drip loop, and ensure the bottom of the drip loop is mounted lower than the conduit connections or the transmitter housing.

Grounding

Use the following techniques to properly ground the transmitter signal wiring and case:

Signal Wiring

Do not run signal wiring in conduit or open trays with power wiring, or near heavy electrical equipment. Signal wiring may be grounded at any one point on the signal loop, or it may be left ungrounded. The negative terminal of the power supply is a recommended grounding point.

Transmitter Case

The transmitter case must be grounded in accordance with national and local electrical codes. The most effective transmitter case grounding method is a direct internal connection to earth ground with minimal impedance.

Internal Ground Connection: Inside the FIELD TERMINALS side of the electronics housing is the Internal Ground Connection screw. This screw is identified by a ground symbol: .

NOTE

Grounding the transmitter case via threaded conduit connection may not provide sufficient ground continuity.

NOTE

The transient protection terminal block (See Figure 4-4 on page 4-8) does not provide transient protection unless the transmitter case is properly grounded. Use the preceding guidelines to ground the transmitter case.

Do not run the transient protection ground wire with signal wiring as the ground wire may carry excessive current if a lightning strike occurs.

Grounding Effects

The capacitance sensing module requires alternating current to generate a capacitance signal. This alternating current is developed in an oscillator circuit with a frequency of approximately 32 kHz. This signal is capacitor-coupled to transmitter-case ground through the sensing module. Because of this coupling, a voltage may be imposed across the load, depending on the choice of grounding. See Figure 2-8.

This impressed voltage, which is seen as high frequency noise, will have no effect on most instruments. Computers with short sampling times will detect a significant noise signal, which should be filtered out by using a large capacitor (1 μ F) or by using a 32 kHz LC filter across the load. Computers are negligibly affected by this noise and do not need filtering

Hazardous Locations Certifications

The Model 1151 was designed with an explosion-proof housing and circuitry suitable for intrinsically safe and non-incendive operation. Factory Mutual explosion-proof certification is standard for the Model 1151 Transmitter. Individual transmitters are clearly marked with a tag indicating the approvals they carry. Transmitters must be installed in accordance with all applicable codes and standards to maintain these certified ratings. Refer to **Hazardous Locations Certifications** on page 6-2 for information on the approvals associated with the analog Model 1151.

FIGURE 2-8. Typical Effects of Grounding on Accuracy for Fast Sample Computers (4-20 mA loops only).

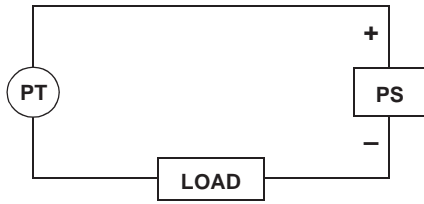

Ungrounded System

Impressed Voltage: 12 to 22 mVp-p
32 kHz

Effect: 0.01% of span.

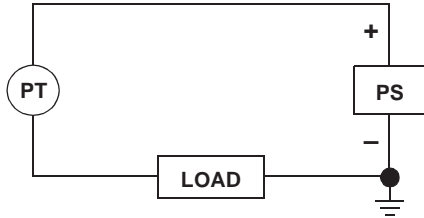

Ground Between Negative Side of Power Supply and Load

Impressed Voltage: 35 to 60 mVp-p
32 kHz

Effect: 0.03% of span.

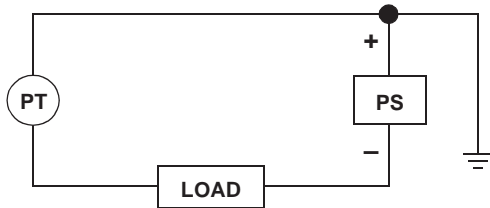

Ground Between Positive Side of Transmitter and Power Supply

Impressed Voltage: 35 to 60 mVp-p
32 kHz

Effect: 0.03% of span.

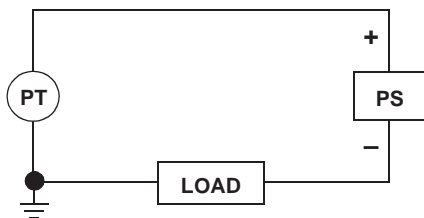

Ground Between Negative Terminal of Transmitter and Load

Impressed Voltage: 500 to 600 mVp-p
32 kHz

Effect: 0.27% of span.

NOTE

Typical effects caused by the impressed voltage on a computer with a sampling time of 100 microseconds using a 2 to 10 volt signal.

LIQUID LEVEL MEASUREMENT

Differential pressure transmitters used for liquid level applications measure hydrostatic pressure head. Liquid level and specific gravity of a liquid are factors in determining pressure head. This pressure is equal to the liquid height above the tap multiplied by the specific gravity of the liquid. Pressure head is independent of volume or vessel shape.

Open Vessels

A pressure transmitter mounted near a tank bottom measures the pressure of the liquid above.

Make a connection to the high pressure side of the transmitter, and vent the low pressure side to the atmosphere. Pressure head equals the liquid's specific gravity multiplied by the liquid height above the tap.

Zero range suppression is required if the transmitter lies below the zero point of the desired level range. Figure 2-9 shows a liquid level measurement example.

Closed Vessels

Pressure above a liquid affects the pressure measured at the bottom of a closed vessel. The liquid specific gravity multiplied by the liquid height plus the vessel pressure equals the pressure at the bottom of the vessel.

To measure true level, the vessel pressure must be subtracted from the vessel bottom pressure. To do this, make a pressure tap at the top of the vessel and connect this to the low side of the transmitter. Vessel pressure is then equally applied to both the high and low sides of the transmitter. The resulting differential pressure is proportional to liquid height multiplied by the liquid specific gravity.

Dry Leg Condition

Low-side transmitter piping will remain empty if gas above the liquid does not condense. This is a dry leg condition. Range determination calculations are the same as those described for bottom-mounted transmitters in open vessels, as shown in Figure 2-9.

FIGURE 2-9. Liquid Level Measurement Example.

Let **X** equal the vertical distance between the minimum and maximum measurable levels (500 in.).
 Let **Y** equal the vertical distance between the transmitter datum line and the minimum measurable level (100 in.).
 Let **SG** equal the specific gravity of the fluid (0.9).
 Let **h** equal the maximum head pressure to be measured in inches of water.
 Let **e** equal head pressure produced by **Y** expressed in inches of water.
 Let **Range** equal **e** to **e + h**.
 Then $h = (X)(SG)$
 $= 500 \times 0.9$
 $= 450 \text{ inH}_2\text{O}$
 $e = (Y)(SG)$
 $= 100 \times 0.9$
 $= 90 \text{ inH}_2\text{O}$
Range = 90 to 540 inH₂O

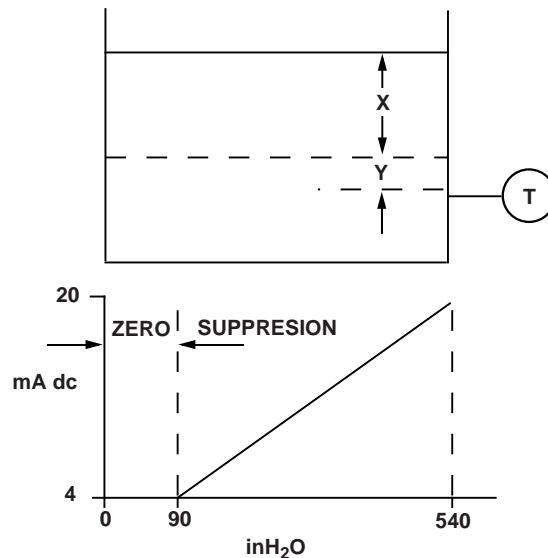

2024-0171A, 0172A

Wet Leg Condition

Condensation of the gas above the liquid slowly causes the low side of the transmitter piping to fill with liquid. The pipe is purposely filled with a convenient reference fluid to eliminate this potential error. This is a wet leg condition.

The reference fluid will exert a head pressure on the low side of the transmitter. Zero elevation of the range must then be made. See Figure 2-10.

FIGURE 2-10. Wet Leg Example.

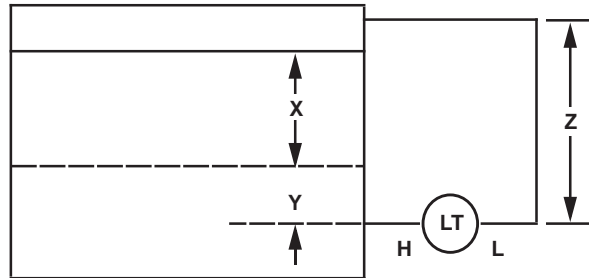

2024-0168A

Let **X** equal the vertical distance between the minimum and maximum measurable levels (500 in.).
 Let **Y** equal the vertical distance between the transmitter datum line and the minimum measurable level (50 in.).
 Let **z** equal the vertical distance between the top of the liquid in the wet leg and the transmitter datum line (600 in.).
 Let **SG₁** equal the specific gravity of the fluid (1.0).
 Let **SG₂** equal the specific gravity of the fluid in the wet leg (1.1).
 Let **h** equal the maximum head pressure to be measured in inches of water.
 Let **e** equal the head pressure produced by **Y** expressed in inches of water.
 Let **s** equal head pressure produced by **z** expressed in inches of water.
 Let **Range** equal **e - s** to **h + e - s**.

$$\begin{aligned} \text{Then } h &= (\mathbf{X})(\mathbf{SG}_1) \\ &= 500 \times 1.0 \\ &= 500 \text{ in H}_2\text{O} \\ e &= (\mathbf{Y})(\mathbf{SG}_1) \\ &= 50 \times 1.0 \\ &= 50 \text{ inH}_2\text{O} \\ s &= (\mathbf{z})(\mathbf{SG}_2) \\ &= 600 \times 1.1 \\ &= 660 \text{ inH}_2\text{O} \end{aligned}$$

$$\begin{aligned} \text{Range} &= \mathbf{e - s} \text{ to } \mathbf{h + e - s} \\ &= 50 - 660 \text{ to } 500 + 50 - 660 \\ &= -610 \text{ to } -110 \text{ inH}_2\text{O} \end{aligned}$$

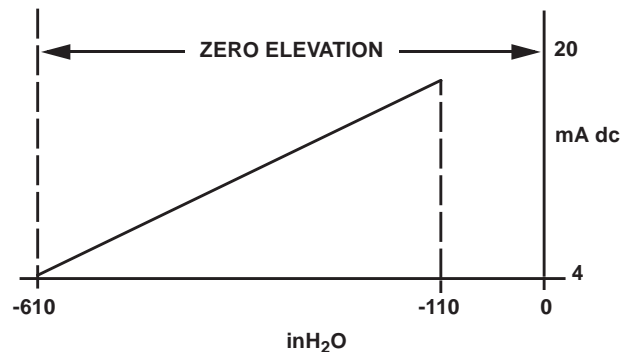

2024-0167A

Bubbler System in Open Vessel

A bubbler system that has a top-mounted pressure transmitter can be used in open vessels. This system consists of an air supply, pressure regulator, constant flow meter, pressure transmitter, and a tube that extends down into the vessel.

Bubble air through the tube at a constant flow rate. The pressure required to maintain flow equals the liquid's specific gravity multiplied by the vertical height of the liquid above the tube opening. Figure 2-11 shows a bubbler liquid level measurement example.

FIGURE 2-11. Bubbler Liquid Level Measurement Example.

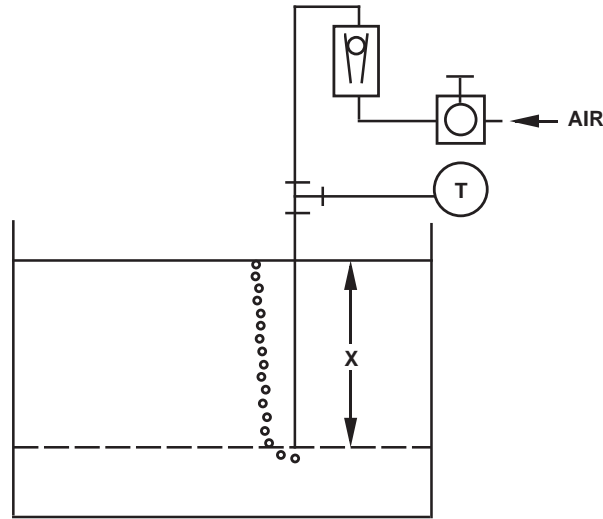

2024-0165A

Let **X** equal the vertical distance between the minimum and maximum measurable levels (100 in.).
 Let **SG** equal the specific gravity of the fluid (1.1).
 Let **h** equal the maximum head pressure to be measured in inches of water.
 Let **Range** equal zero to **h**.
 Then $h = (X)(SG)$
 $= 100 \times 1.1$
 $= 110 \text{ inH}_2\text{O}$
Range = 0 to 110 inH₂O

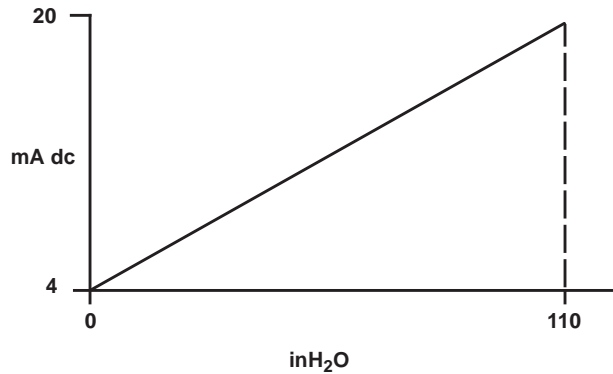

2024-0166A

Calibration

Calibration of the Rosemount Model 1151 Pressure Transmitter is simplified by its compact and explosion-proof design, external span and zero adjustments, separate compartments for electronics and wiring, and weatherproof construction. Descriptions of span, linearity, zero adjustments, and damping follow.

⚠ WARNING

Explosions can cause death or serious injury. Both transmitter covers must be fully engaged to meet explosion-proof requirements.

⚠ CAUTION

When replacing housing covers, tighten the covers enough to make contact with the O-ring seals. If the covers are not tightened enough, moisture can enter the housing and cause transmitter failure.

QUICK CALIBRATION PROCEDURE (FOR E, G, AND J ELECTRONICS)

The following Quick Calibration Procedures are for those users who are already familiar with the analog Model 1151.

NOTE

The zero and span adjustments are interactive. For applications requiring large elevated or suppressed values, refer to **Elevated or Suppressed Zeros** on page 3-7.

1. Apply 4 mA-point pressure and turn zero screw to output 4 mA.
2. Apply 20 mA-point pressure.
3. Subtract actual output from desired output.
4. Divide difference by 3.
5. Turn span screw above or below desired output by value in Step 4.
6. Repeat Steps 1 through 5 until calibrated.

QUICK CALIBRATION PROCEDURE (FOR L AND M ELECTRONICS)

1. Apply 1 V dc-point pressure for M electronics (0.8 V dc for L electronics) and turn zero screw to output 1 V dc (0.8 V dc for L electronics).
2. Apply 5 V dc-point pressure (M electronics) or 3.2 V dc (L electronics).
3. Subtract actual output from desired output.
4. Divide difference by 3.
5. Turn span screw above or below desired output by value in Step 4.
6. Repeat Steps 1 through 5 until calibrated.

Example for a Model 1151DP Range 4: For a desired calibration of 0 to 100 inH₂O, use the following procedure:

1. Adjust the zero. With zero input applied to the transmitter, turn the zero adjustment screw until the transmitter reads 4 mA.
2. Adjust the span. Apply 100 inH₂O to the transmitter high side connection. Turn the span adjustment screw until the transmitter output reads approximately 20 mA.
3. Release the input pressure and readjust the zero output to read 4 mA ± 0.032 mA.
4. Re-apply 100 inH₂O to the transmitter. If the output reading is greater than 20 mA, divide the difference by 3, and subtract the result from 20 mA. Adjust the 100% output to this value.

If the output reading is less than 20 mA, divide the difference by 3 and add the result to 20 mA. Adjust the 100% output to this value.

Example: The full scale transmitter output is 20.100 mA. Dividing 0.100 by 3.0 gives the product 0.033. Subtracting the product 0.033 from 20.00 mA gives the difference 19.967 mA. Adjust the 100% output to this value.

5. Release input pressure and readjust the zero.
6. Apply 100% input and repeat Steps 3 through 5 if the full scale output is not 20 ± 0.032 mA.

NOTE

Under operating conditions that subject the transmitter to temperature extremes or significant vibration, mechanical backlash may occur in the zero and span adjustment screws. To improve the stability of zero and span settings in these circumstances, back off the adjustment screws slightly after final adjustment to break contact between the potentiometer blades and the adjustment screw slot surfaces.

DATA FLOW WITH CALIBRATION OPTIONS

Figure 3-1 illustrates the Model 1151 Transmitter data flow with calibration tasks.

FIGURE 3-1. Model 1151 Transmitter Data Flow with Calibration Options.

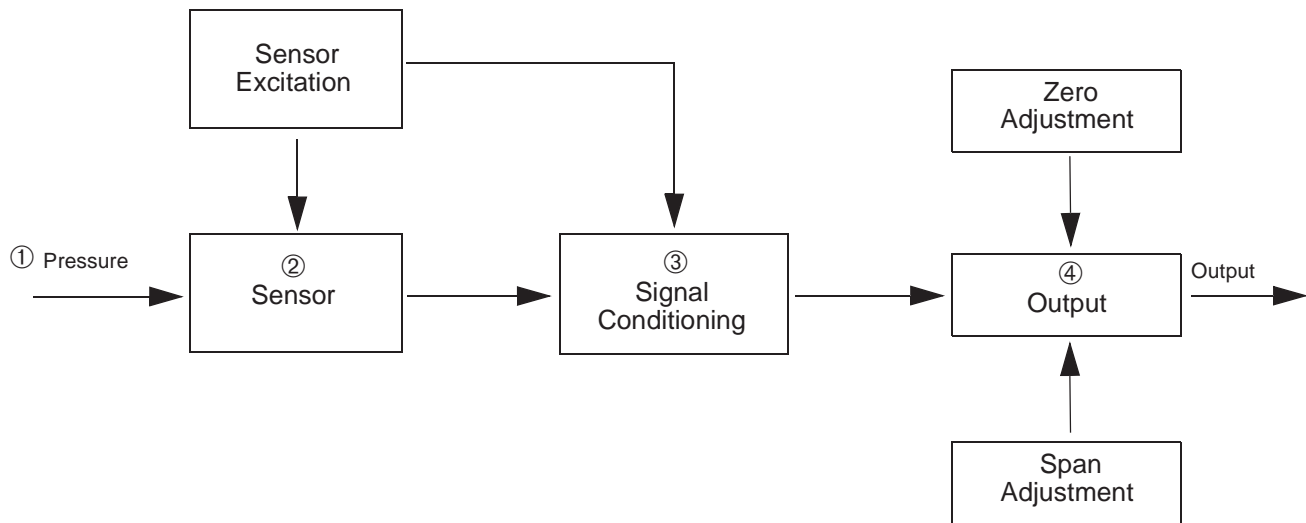

This data flow can be summarized in four major steps:

1. Pressure is applied to the sensor.
2. A change in pressure is measured by a change in the sensor output.
3. The sensor signal is conditioned for various parameters.
4. The conditioned signal is converted to an appropriate analog output.

SPAN ADJUSTMENT RANGE

The span on a Model 1151 with E, G, and J output options is continuously adjustable to allow calibration anywhere between maximum span and one-sixth of maximum span. For example, the span on a Range 4 transmitter can be adjusted between 25 and 150 inH₂O (6.2 and 37.2 kPa).

ZERO ADJUSTMENT RANGE

The zero on a Model 1151 with the E or G output options can be adjusted for up to 500% suppression or 600% elevation. See Figure 3-2.

FIGURE 3-2. Zero Adjustment Range.

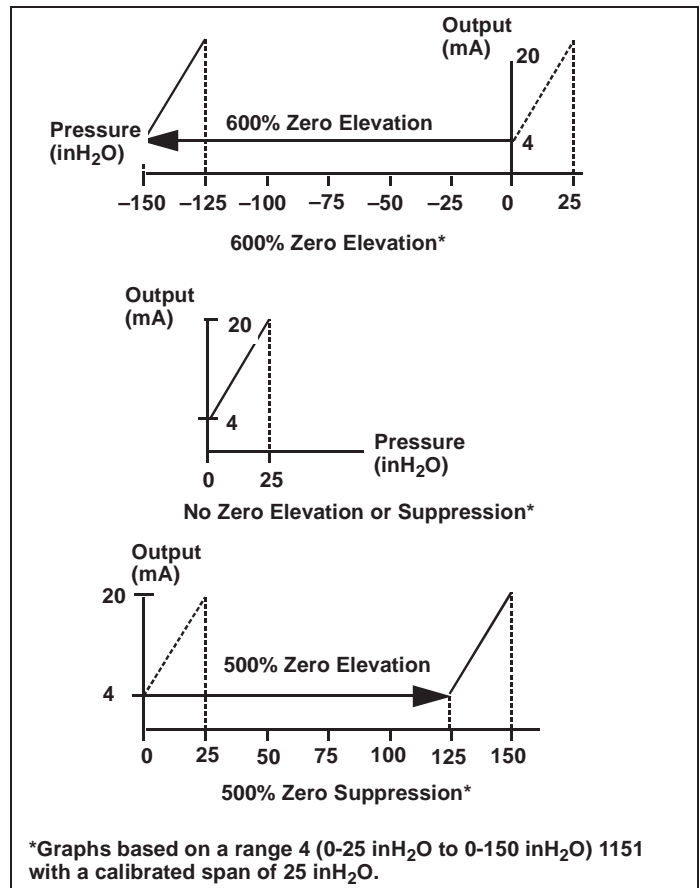

1151-0193A

The zero may be elevated or suppressed to these extremes with the limitation that no pressure within the calibrated range exceeds the full-range pressure limit. For example, a Range 4 transmitter cannot be calibrated for 100 to 200 inH₂O (24.8 to 49.7 kPa) (only 100% zero suppression) because 200 inH₂O exceeds the 150 inH₂O full-range pressure limit of a Range 4.

To make large elevation or suppression adjustments, it is necessary to move the jumper on the component side of the amplifier board. Figure 3-3 on page 3-5 shows elevation and suppression jumper settings. The jumper has three positions. The middle position allows normal levels of elevation or suppression. For larger adjustments, move the jumper to the ELEVATE ZERO (EZ) or SUPPRESS ZERO (SZ) as marked.

NOTE

Always make sure that the jumper is fully seated on its pins. If the jumper has not been placed in any of the three positions, the amplifier board will provide normal levels of elevation or suppression. A slide switch replaces the jumper pin on some versions of the amplifier board.

FIGURE 3-3. Elevation and Suppression Jumper Settings.

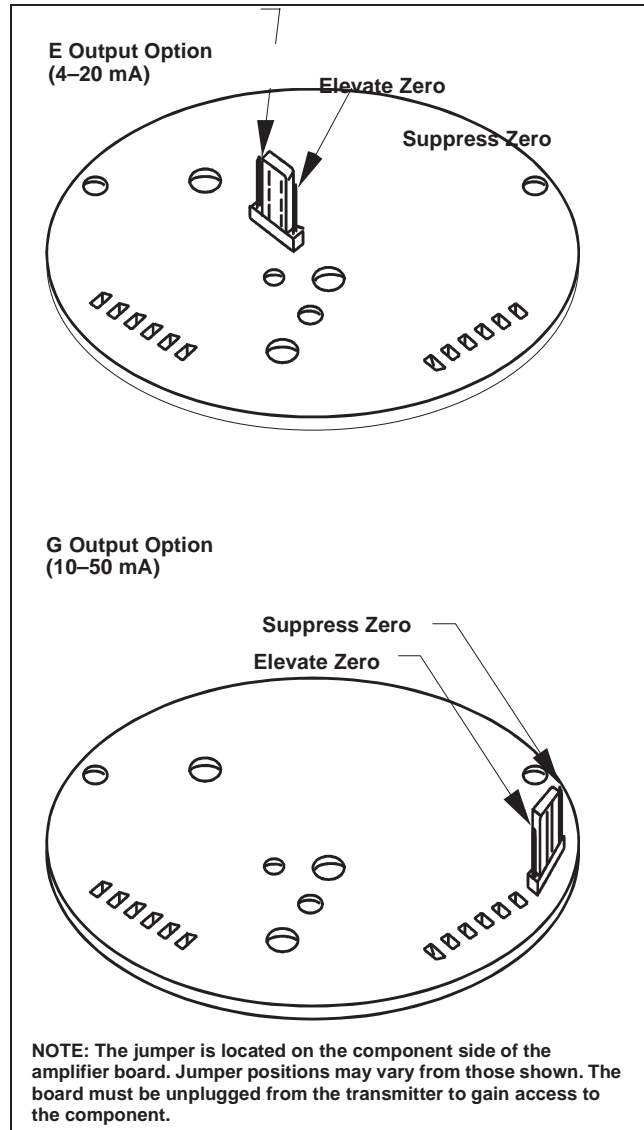

1151-0194A

ZERO AND SPAN ADJUSTMENT

The zero and span adjustment screws are accessible externally behind the nameplate on the terminal side of the electronics housing. See Figure 3-4. The output of the transmitter increases with clockwise rotation of the adjustment screws. The zero adjustment screw and ELEVATE ZERO/SUPPRESS ZERO jumper do not affect the span. Span adjustment, however, does affect zero. This effect is minimized with zero-based spans. Therefore, when calibrations having elevated or suppressed zeros are made, it is easier to make a zero-based calibration and achieve the required elevation or suppression by adjusting the zero adjustment screw (and ELEVATE ZERO/SUPPRESS ZERO jumper as required).

A degree of mechanical backlash is present in the zero and span adjustments, so there will be a dead band when the direction of adjustment is changed. Because of the backlash, the simplest procedure is to purposely overshoot a larger amount before reversing the direction of the adjustment.

FIGURE 3-4. Zero and Span Adjustment Screws.

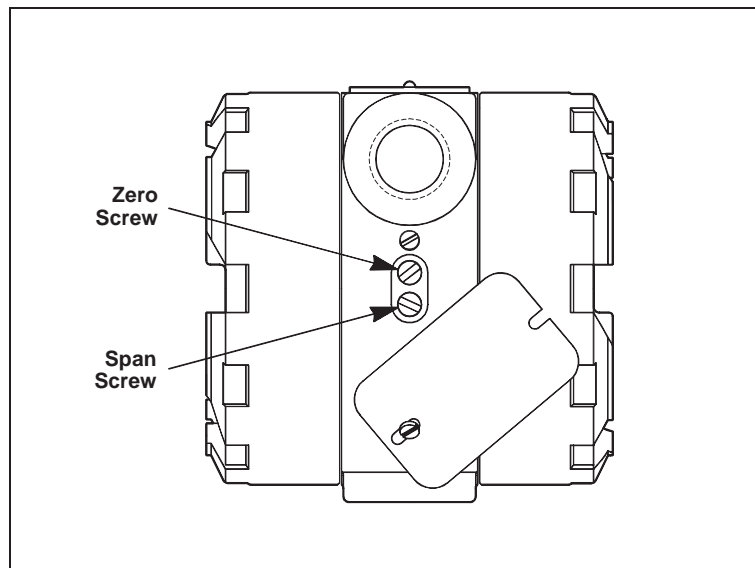

1151-1151A25A

ELEVATED OR SUPPRESSED ZEROS

Non-zero-based calibrations are termed as having “elevated” or “suppressed” zeros. Calibrations that have a lower calibrated value below zero are termed elevated. Compound ranges are included in this category. Calibrations that have a lower calibrated value above zero are termed suppressed.

The easiest way to calibrate transmitters with elevated or suppressed zeros is to perform a zero-based calibration and then elevate or suppress the zero by adjusting the zero adjustment screw.

Model 1151DP Range 4 Suppression Example: For a desired calibration of 20 to 120 inH₂O (4.9 to 29.8 kPa), proceed as follows:

1. Calibrate the transmitter to 0 to 100 inH₂O (0 to 24.8 kPa) as described in the zero and span adjustment information.
2. Apply 20 inH₂O (4.9 kPa) to the high side process connection, and adjust the zero until the transmitter output reads 4 mA.

Do not use the span adjustment.

Model 1151DP Range 4 Elevation Example: For a calibration of -120 to -20 inH₂O (-29.8 to -4.9 kPa), proceed as follows:

1. Calibrate the transmitter to 0 to 100 inH₂O (0 to 24.8 kPa) as described in the zero and span adjustment information.
2. Apply 120 inH₂O (29.8 kPa) to the low side process connection, and adjust the zero until the transmitter output reads 4 mA.

Do not use the span adjustment.

NOTE

For large amounts of elevation or suppression, it may be necessary to reposition the ELEVATE/SUPPRESS ZERO jumper. To do this, remove the amplifier board, and move the jumper to the ELEVATE or SUPPRESS position as required. See Figure 3-3 on page 3-5.

LINEARITY ADJUSTMENT

In addition to the span and zero adjustments, a linearity adjustment screw (marked LIN) is located on the solder side of the amplifier board. See Figure 3-5. This is a factory calibration adjusted for optimum performance over the calibrated range of the instrument and normally is not readjusted in the field. The user may, however, maximize linearity over a particular range using the following procedure:

1. Apply mid-range pressure and note the error between the theoretical and actual output signal.
2. Apply full-scale pressure. Multiply the error noted in Step 1 by six and then that product by the Range Down Factor, which is calculated as shown below:

$$\text{Range Down Factor} = \frac{\text{Maximum Allowable Span}}{\text{Calibrated Span}}$$

Add this result to the full-scale output (for negative errors), or subtract the result from the full-scale output (for positive errors) by turning the linearity adjustment screw.

Example: At 4 to 1 Range Down Factor, the mid-scale point is low by 0.05 mA. Therefore, turn the linearity adjustment screw until full-scale output increases by $(0.05 \text{ mA} \times 6 \times 4) = 1.2 \text{ mA}$.

3. Readjust the zero and span.

FIGURE 3-5. Damping and Linearity Adjustment Screws.

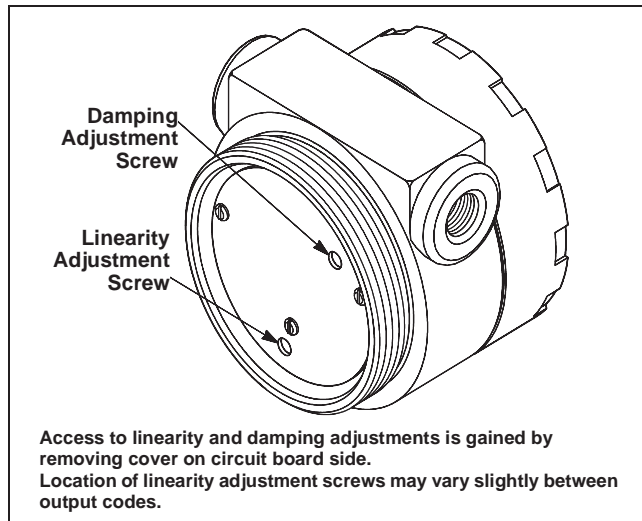

DAMPING ADJUSTMENT

The amplifier boards for output options E, G, and J are designed to permit damping of rapid pulsations in the pressure source through adjustment of the damping screw shown in Figure 3-5 on page 3-8. The adjustment is marked DAMP on the solder side of the amplifier board.

The settings available provide time constant values between 0.2 and 1.66 seconds. The instrument is calibrated and shipped with this control set at the counterclockwise stop (0.2 second time constant). It is recommended that the shortest possible time constant setting be selected. Since the transmitter calibration is not influenced by the time constant setting, the damping may be adjusted with the transmitter connected to the process. Turn the damping control clockwise until the desired damping is obtained.

⚠ CAUTION

The adjustment screw has positive stops at both ends. Forcing it beyond the stops may cause permanent damage.

STATIC PRESSURE SPAN CORRECTION FACTOR

High static pressure causes a systematic span shift in the transmitter. It is linear and easily correctable during calibration. Table 3-1 shows the amount of span shift for range codes 3 through 8.

TABLE 3-1. Model 1151 DP/HP Span Shift.

Range Code	Span Shift % Input Per 1,000 psi		
	316L SST	Hastelloy	Monel
3	-1.75%	-1.00%	-1.00%
4	-0.87%	-0.60%	-0.50%
5	-0.81%	-0.70%	-0.75%
6	-1.45%	-1.45%	-1.45%
7	-1.05%	-1.05%	-1.05%
8	-0.55%	-0.55%	-0.55%

The following examples illustrate a compensation method of accounting for the span shift. For more complicated calibration conditions, refer to Rosemount Report D8500141 or contact Customer Central at 1-800-999-9307.

Example 1 - Refer to Table 3-1: One method is to adjust the input and allow the transmitter output to remain at 20 mA. Use the following formula:

Corrected Input

$$= \text{Desired URV} + [(S \times \text{URV}) \times (P/1000)],$$

Where S = Value from Table 3-1, divided by 100.

To calibrate a Range 4 transmitter 0 to 150 inH₂O (0 to 37.2 kPa) and correct for 1,500 psi static line pressure, use the following correction:

Corrected Input

$$= 150 + [(-0.0087 \times 150) \times (1500/1000)]$$

$$= 148.04 \text{ inches}$$

With 148.04 inches applied as input at atmospheric pressure, set the transmitter to 20 mA. When the transmitter is exposed to 1,500 psi static line pressure, output will be 20 mA at 150 inches input.

Where computers or microprocessor receivers are used, the mathematical definitions used in the preceding tables can be used to automatically and continuously make the correction.

All transmitters should be rezeroed under line pressure to remove zero

error.

Example 2 - Refer to Table 3-2: A Model 1151DP Range 4 with a 4–20 mA output operating at 1,200 psi static pressure requires the output at 100% to be corrected to 20.168 mA. Therefore, the transmitter should be adjusted from 4–20.168 mA during calibration. After installation, and with both process inputs pressurized to 1,200 psi, readjust the zero to 4.000 mA to remove the small zero error.

TABLE 3-2. Model 1151DP Static Pressure 4–20 mA Output Code E Corrected Output Calibration at 100% Input SST Isolators.

Static Pressure (psi)	Static Pressure (kPa)	Range 3	Range 4	Range 5
100	689	20.029	20.014	20.013
200	1379	20.057	20.028	20.026
300	2068	20.086	20.042	20.039
400	2758	20.114	20.056	20.052
500	3447	20.143	20.070	20.066
600	4137	20.171	20.084	20.079
700	4826	20.200	20.098	20.092
800	5516	20.228	20.112	20.104
900	6205	20.257	20.126	20.118
1000	6895	20.285	20.140	20.131
1100	7584	20.314	20.154	20.144
1200	8274	20.342	20.168	20.157
1300	8963	20.371	20.182	20.170
1400	9653	20.399	20.196	20.183
1500	10342	20.428	20.210	20.197
1600	11032	20.456	20.224	20.210
1700	11721	20.485	20.238	20.223
1800	12411	20.513	20.252	20.236
1900	13100	20.542	20.266	20.250
2000	13790	20.570	20.280	20.262

Example 3 - Refer to Table 3-3: The correction factor at 100% input shift for a Range 5 transmitter with a 4–20 mA output operating at 1,500 psi static pressure would be:

$$S = 0.131 \times 1.5 = 0.197 \text{ mA}$$

Therefore, the calibration for this transmitter would be from 4–20.197 mA.

TABLE 3-3. Output Correction Factors SST Isolators.

Range Code	E Output 4–20 mA	G Output 10–50 mA
3	S = 0.285 P	S = 0.712 P
4	S = 0.140 P	S = 0.350 P
5	S = 0.131 P	S = 0.327 P
6	S = 0.235 P	S = 0.588 P
7	S = 0.170 P	S = 0.425 P
8	S = 0.088 P	S = 0.220 P

NOTE

Correction factors apply to E and G outputs at 100% input (P = static pressure in 1,000 psi).

Options

Model 1151 options can simplify installation and operation. This section describes the following options:

- Mounting Brackets
- Analog and LCD Indicating Meters
- Terminal Blocks (Transient Protection and Filter)

MOUNTING BRACKETS

(OPTION CODES B1–B7 AND B9)

Optional mounting brackets available with the Model 1151 allow mounting to a 2-inch pipe or panel. Figure 4-1 shows bracket dimensions and mounting configurations for the various bracket options.

Pipe Mounting Brackets

Option Codes B1, B4, and B7 are sturdy, epoxy-polyester-painted brackets designed for 2-inch pipe mounting. Option Code B1 is constructed of carbon steel with carbon steel bolts. Option Code B4 is the same bracket as Option Code B1, with 316 SST bolts. Option Code B7 is also the same bracket as Option Code B1 with a 316 SST bracket and 316 SST bolts.

Flat Mounting Brackets

Option Codes B3, B6, and B9 are flat brackets designed for 2-inch pipe mounting. Option Code B3 is constructed of carbon steel with a carbon steel U-bolt. Option Codes B6 and B9 are the same bracket configuration as Option Code B3. Option Code B6 provides 316 SST bolts and Option Code B9 provides a 316 SST bracket and 316 SST bolts.

Panel Mounting Brackets

Option codes B2 and B5 are panel brackets designed for bolting to any flat surface.

FIGURE 4-1. Mounting Bracket Options.

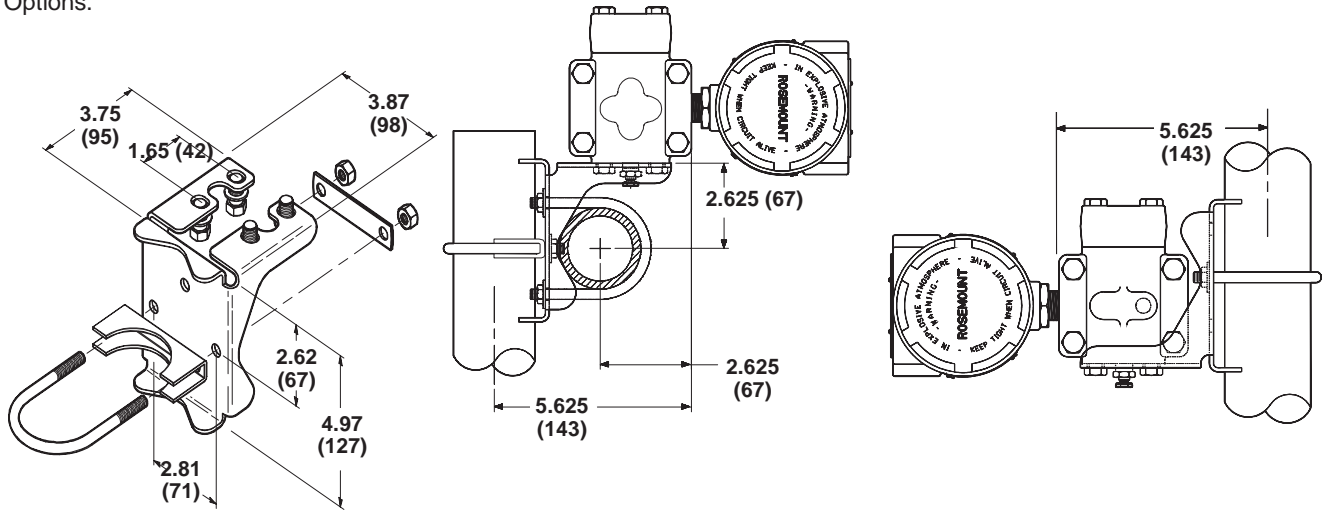

PIPE MOUNTING BRACKET OPTION CODES B1, B4, AND B7

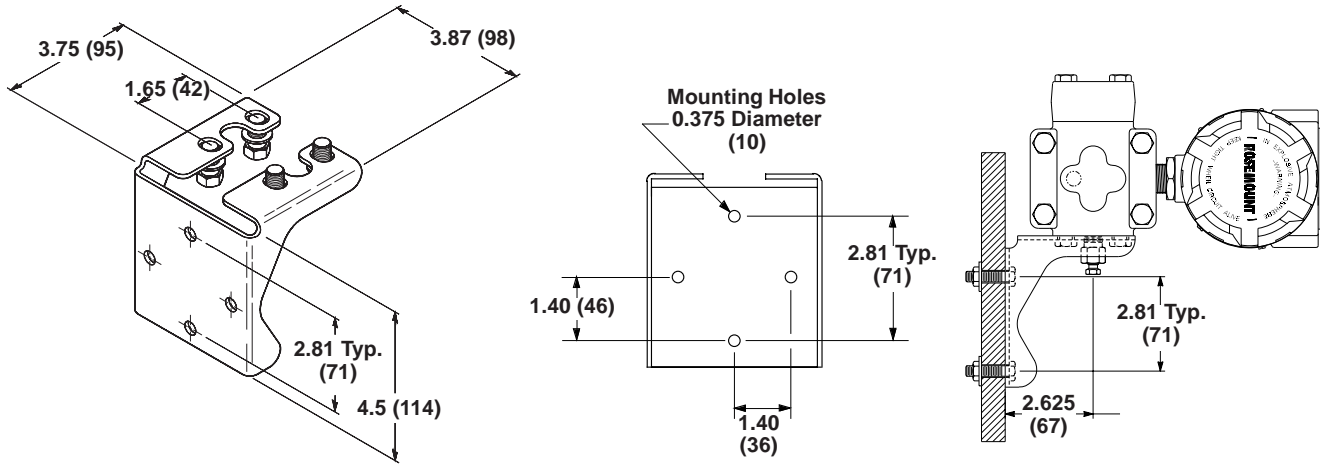

PANEL MOUNTING BRACKET OPTION CODES B2 AND B5

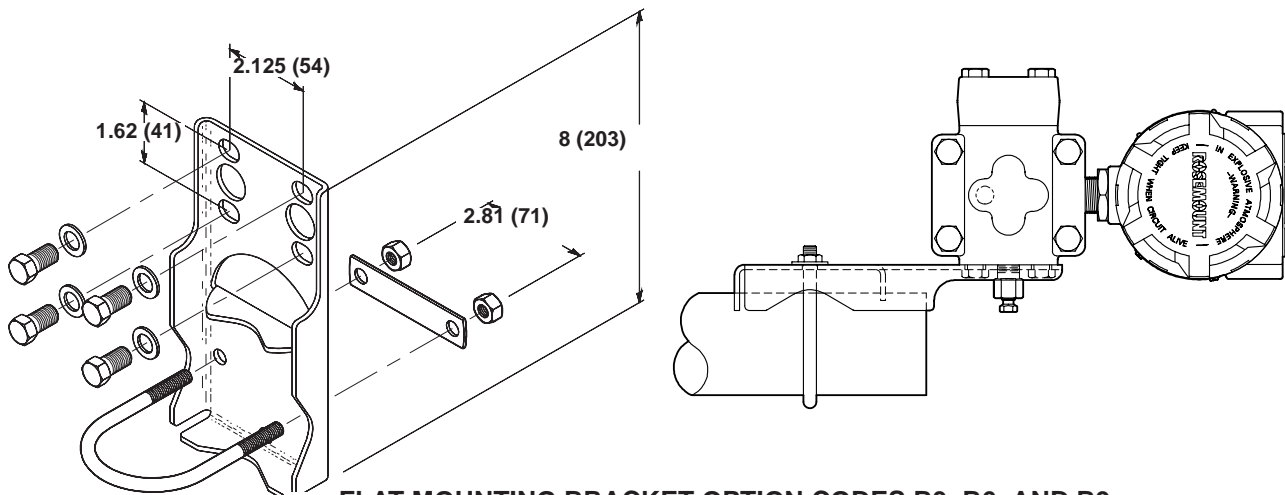

FLAT MOUNTING BRACKET OPTION CODES B3, B6, AND B9

NOTE
Dimensions are in inches (millimeters).

3051-3051D19A, 1151-1151D,B06C

3051-3051B19A, 1151-0244A, 1151-1151E06A

3051-3051H19B, 1151-1151F06B

ANALOG METERS (4–20 mA ONLY)

Option Codes M1–M3 and M6 provide local indication of the transmitter output in a variety of scaling configurations with an indicator accuracy of ± 2 percent. The plug-in mounting configuration allows for simple installation and removal of the analog meters. The meter scaling options are shown below.

- M1 Linear analog meter, 0-100% scale
- M2 Square-root analog meter, 0-100% flow scale
- M3 Special scaling analog meter, (specify range)
- M6 Square-root analog meter, 0-10 $\sqrt{\quad}$ scale

⚠ WARNING

Explosions can cause death or serious injury. To meet hazardous location requirements, any transmitter with a tag specifying Option Codes I5, I1, N1, I8, I7, or N7 requires an intrinsically safe analog meter (Part No. 01151-0744-XXXX) or an LCD Meter (Part No. 01151-1300-XXXX).

LCD METERS (4–20 mA ONLY)

The LCD meter options, M4 and M7–M9 provide a highly accurate local display of the process variable. A variety of scaling configurations are available and listed as follows:

- M4 Linear LCD Meter, 0 to 100%, User Selectable
- M7 Special scale LCD meter (specify range, mode, and engineering units)
- M8 Square-root LCD meter, 0 to 100%
- M9 Square-root LCD meter, 0 to 10 $\sqrt{\quad}$

⚠ WARNING

Explosions can cause death or serious injury. When adding a meter option to a Model 1151 with an Option Code R1 or R2 terminal block, make sure to change to cemented meter covers with a glass window. Make sure a sticker is located inside the cover that indicates a "cemented cover." This cover is required to maintain explosion-proof approval.

LCD Meter Configuration

The Rosemount LCD meter plugs directly into the Model 1151 to provide a highly accurate digital display of the process variable. The following explains the configuration and assembly of the LCD meter and includes the applicable functional, performance, and physical specifications. This meter adds no voltage drop in the 4–20 mA current loop when connected directly across the transmitter test terminals.

The LCD meter may be configured to meet specific requirements by using the left and right calibration buttons located on the meter face as shown in Figure 4-2. The analog bar graph is also shown in Figure 4-2. The 20-segment bar graph is factory calibrated and represents 4–20 mA directly.

FIGURE 4-2. LCD Meter.

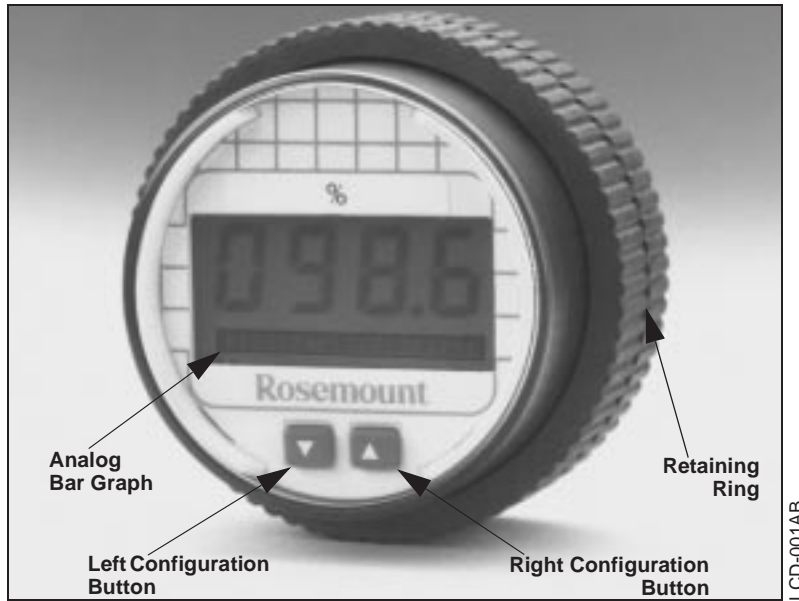

No calibration equipment is required to configure the LCD meter, but there must be a current (between 4 and 20 mA) flowing through the loop. The actual value of the current is not significant. In addition, meter configuration does not affect the transmitter/loop current. Use the following meter configuration procedure to properly configure the LCD meter.

Remove the Cover

1. Unscrew the retaining ring shown in Figure 4-2 and lift the transparent cover off of the housing.

NOTE

The LCD meter time-out is approximately 16 seconds. If keys are not pressed within this period, the indicator reverts to reading the current signal.

Position the Decimal Point and Select the Meter Function

2. Press the left and right configuration buttons simultaneously and release them immediately.
3. To move the decimal point to the desired location, press the left configuration button. Note that the decimal point wraps around.
4. To scroll through the mode options, press the right configuration button repeatedly until the desired mode is displayed. See Table 4-1.

TABLE 4-1. LCD Meter Modes.

Options	Relationship between Input Signal and Digital Display
L in	Linear
L inF	Linear with five-second filter
Srt	Square root
SrtF	Square root with five-second filter
<p>Square root function only relates to the digital display. The bar graph output remains linear with the current signal.</p> <p>Square root response The digital display will be proportional to the square root of the input current where 4 mA=0 and 20 mA=1.0, scaled per the calibration procedure. The transition point from linear to square root is at 25% of full scale flow.</p> <p>Filter response operates upon “present input” and “input received in the previous five second interval” in the following manner: $\text{Display} = (0.75 \times \text{previous input}) + (0.25 \times \text{present input})$ This relationship is maintained provided that the previous reading minus the present reading is less than 25% of full scale.</p>	

Store the Information

5. Press both configuration buttons simultaneously for two seconds. Note that the meter displays “----” for approximately 7.5 seconds while the information is being stored.

Set the Display Equivalent to a 4 mA Signal

6. Press the left button for two seconds.
7. To decrement the display numbers, press the left configuration button and to increment the numbers, press the right configuration button. Set the numbers between -999 and 1000.
8. To store the information, press both configuration buttons simultaneously for two seconds.

Set the Display Equivalent to a 20 mA Signal

9. Press the right button for two seconds.
10. To decrement the display numbers, press the left configuration button on the display and to increment the numbers, press the right configuration button. Set the numbers between -999 and 9999. The sum of the 4 mA point and the span must not exceed 9999.
11. To store the information, press both configuration buttons simultaneously for two seconds. The LCD meter is now configured.

Replace the Cover

12. Make sure the rubber gasket is seated properly, replace the transparent cover, and replace the retaining ring.

LCD Meter Assembly

Figure 4-3 shows the mounting hardware required to properly install the LCD meter on a transmitter or in the field signal indicator. This mounting hardware may also be used with the Rosemount universal (analog) meter.

FIGURE 4-3. LCD Meter Exploded View.

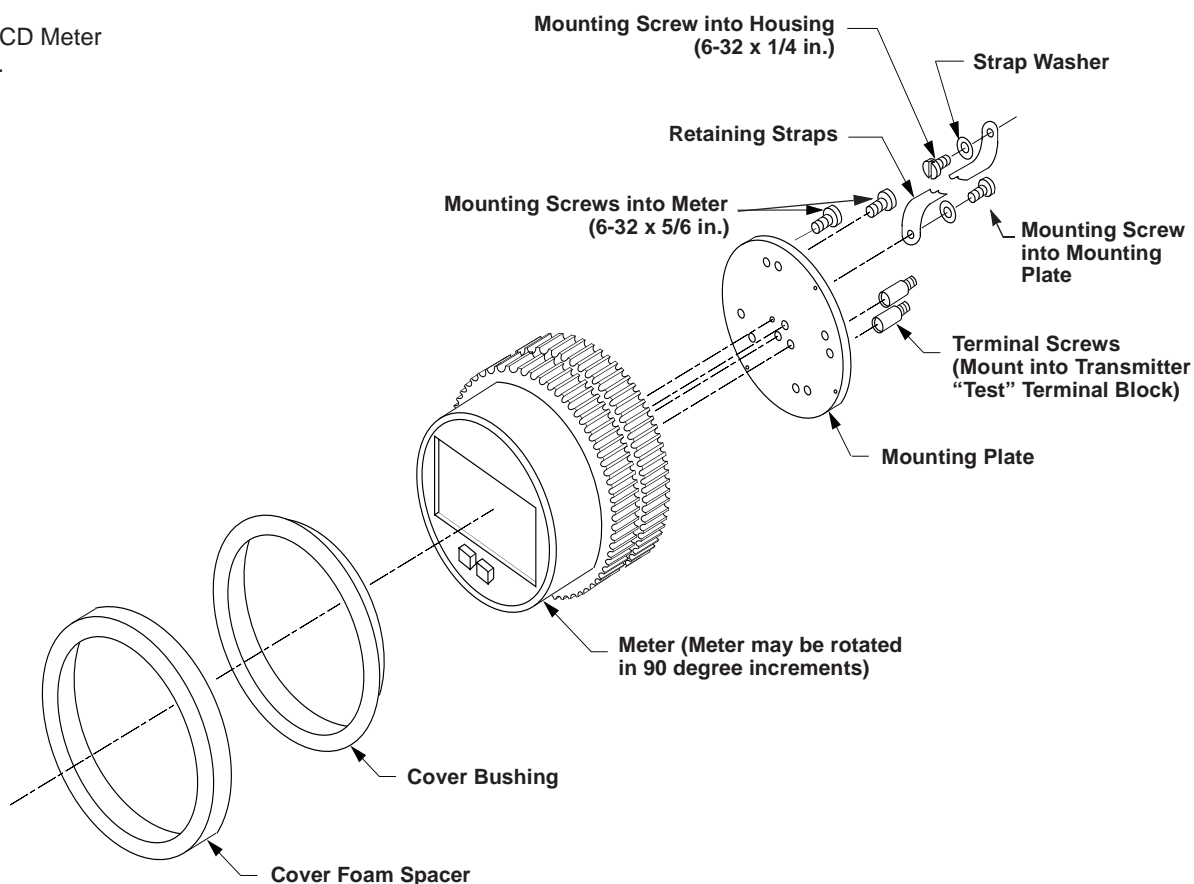

LCD Meter Specifications

Input Signal

4–20 mA dc.

Meter Indication

4-digit LCD showing –999 to 9999. A 20-segment bar graph directly represents the 4–20 mA current.

Scaling/Calibration

4 mA Point Limits: –999 to 1000.

Span limits: 0200 to 9999.

The sum of the 4 mA point and span must not exceed 9999.

Adjustments are made using non-interactive zero and span buttons.

Hazardous Locations Certifications

Approved for use with Model 1151.

WARNING

Explosions can cause death or serious injury. When adding a meter option to a Model 1151 with an Option Code R1 or R2 terminal block, make sure to change to cemented meter covers with a glass window. Make sure a sticker is located inside the cover that indicates a “cemented cover.” This cover is required to maintain explosion-proof approval.

Overload Limitation

666 mA.

Temperature Limits

Storage: –40 to 185 °F (–40 to 85 °C).

Operating: –4 to 158 °F (–20 to 70 °C).

Between temperatures –40 to –4 °F (–40 to –20 °C), the loop is intact and the meter is not damaged.

Humidity Limitation

0 to 95% non-condensing relative humidity.

Update Period

750 ms.

Response Time

Responds to changes in input within a maximum of two update periods. If the filter is activated, then the display responds to the change within nine update periods.

Digital Display Resolution

0.05% of calibrated range ± 1 digit.

Analog Bar Graph Resolution

5.0% of calibrated range.

Indication Accuracy

0.25% of calibrated range ± 1 digit.

Stability

Over Time: 0.1% of calibrated range ± 1 digit per 6 months.

Temperature Effect

0.01% of calibrated range per °C on zero.

0.02% of calibrated range per °C on span over the operating temperature range.

Power Interrupt

All calibration constants are stored in EEPROM memory and are not affected by power loss.

Failure Mode

LCD meter failure will not affect transmitter operation.

Under/Over Range Indication

Input current < 3.5 mA: Display blank.

Input current > 22.0 mA: Display flashes 112.5% of full scale value or 9999, whichever is less.

Meter Size

2¼-inch diameter face with ½-inch high characters.

TERMINAL BLOCKS

The terminal block options can increase the Model 1151 (output code "E" only) Pressure Transmitter's ability to withstand electrical transients induced by lightning, welding, heavy electrical equipment, or switch gears. The Model 1151, with the integral transient protection option, meets the standard performance specifications as outlined in this product manual. In addition, the transient protection circuitry meets IEEE Standard 587, Category B and IEEE Standard 472, Surge Withstand Capability.

NOTE

For a transient protection terminal block, specify Option Code R1 or R9.

FIGURE 4-4. Terminal Blocks.

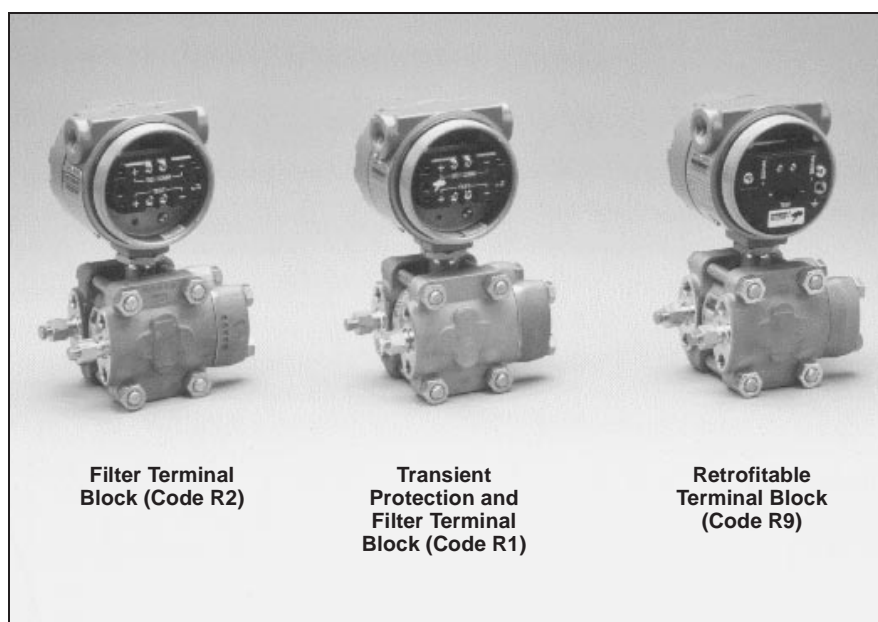

1151-040AB

**Filter Terminal Block
(Option Code R2)**

Option Code R2 provides enhanced performance in extremely harsh EMI and RFI environments. This option cannot be retrofitted.

**Transient Protection and
Filter Terminal Block
(Option Code R1)**

Option Code R1 provides EMI/RFI protection and the benefit of integral transient protection. (This terminal block can be ordered as a spare part to retrofit existing Model 1151 Transmitters with Option Code R2.)

NOTE

Options R1 and R2 do not require the use of shielded cable in most electrically noisy environments.

**Retrofitable Transient
Terminal Block
(Option Code R9)**

The retrofitable transient protection terminal block (Option Code R9) protects any Rosemount Model 1151 Analog Pressure Transmitter (E electronics only without the R1 or R2 option). The terminal block module installs directly into a transmitter providing highly reliable transient protection. Included with the Retrofitable Transient Protection Terminal Block is a hardware kit containing two short mounting screws with two lock washers, one long grounding screw with a square washer, and one label indicating an option has been installed. If any parts of the hardware kit are missing, contact Rosemount North American Response Center at 1-800-THE-RSMT (1-800-654-7768).

R9 Terminal Block Installation

Use a phillips and a flat-blade screwdriver and the following steps to install the Retrofitable Transient Protection Terminal Block:

1. Turn off all power to the Model 1151 on which the terminal block is being installed.

⚠ WARNING

Explosion can cause death or serious injury. Do not remove the instrument cover in explosive atmospheres when the circuit is alive.

2. Unscrew the transmitter terminal-side (indicated on the housing nameplate) cover (on the high side of the transmitter) exposing the standard terminal block.
3. Disconnect wiring to the terminal block.
4. Remove the single grounding screw and the two signal terminal screws, with terminal eyelet washers, from the standard terminal block.
5. Set the Retrofitable Transient Protection Terminal Block into the housing, making sure the ground and signal terminals are properly aligned. See Figure 4-5 on page 4-9.
6. Insert the two short mounting screws with washers in the mounting holes and tighten the terminal block to the transmitter. See Figure 4-5 on page 4-9.
7. Turn the transient protector grounding sleeve, located in the grounding hole, just enough to stabilize the unit on the transmitter. See Figure 4-5 on page 4-9. Over tightening the grounding sleeve will shift the terminal block out of alignment.

FIGURE 4-5. Terminal Block
Exploded View (Option Code R9).

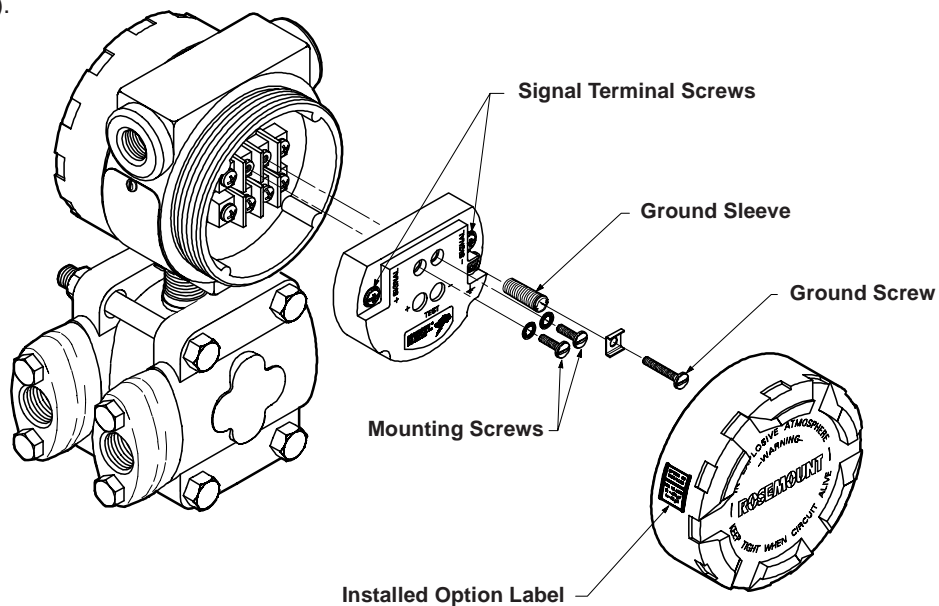

1151-1085A01A

8. Insert the long grounding screw with the square washer into the grounding hole and tighten.
9. Connect the positive power supply wire to the transient protector terminal screw labeled "+ SIGNAL", and the negative power supply wire to the terminal screw labeled "- SIGNAL."
10. Attach the supplied label to the terminal side transmitter cover as shown in Figure 4-5.

⚠ WARNING

Explosions can cause death or serious injury. Both transmitter covers must be fully engaged to meet explosion-proof requirements.

11. Replace the terminal side cover on the transmitter.

**Terminal Block
Specifications
(for R1, R2, and R9)**

Hazardous Locations Certifications

Approved for use with I5, K5, I6, C6, E6, E8, I8⁽¹⁾, I1⁽¹⁾⁽²⁾, N1, E7, I7, and N7 approved transmitters.

Materials of Construction

Noryl plastic.

Loop Resistance

6 Ω.

Transient Protection Limits (for R1 and R9)

IEEE 587 Category B

6 kV Crest ($1.2 \times 50 \mu\text{s}$).

3 kV Crest ($8 \times 20 \mu\text{s}$).

6 kV ($0.5 \mu\text{s}$ at 100 kHz).

IEEE 472

SWC 2.5 kV Crest,

1 MHz waveform.

Accuracy Specification

Same as specified electronics accuracy when transmitter is calibrated with installed Retrofittable Transient Protection Terminal Block.

(1) When the transient version of the filter module is used in an intrinsically safe installation, supply transmitter from a galvanically isolated barrier.

(2) I1 and R1/R9 are not compatible.

Maintenance and Troubleshooting

This section describes a variety of troubleshooting options associated with the Model 1151 Alphaline® transmitter and is divided into the following sections.

Hardware Maintenance

- Hardware Diagnostics
- Transmitter Disassembly
- Sensor Module Checkout
- Transmitter Reassembly
- Optional Plug-in Meters
- Return of Material

Contact Customer Central at 1-800-999-9307 for further technical support and the North American Response Center at 1-800-654-7768 for equipment service assistance.

WARNING

Use only the procedures and new parts specifically referenced in this manual. Unauthorized procedures or parts can affect product performance and the output signal used to control a process, and may render the instrument dangerous. Direct any questions concerning these procedures or parts to Rosemount Inc.

HARDWARE DIAGNOSTICS

If you suspect a malfunction, see Table 5-1 on page 5-2 to verify that transmitter hardware and process connections are in good working order. Under each of the five major symptoms, you will find specific suggestions for solving the problem. Always deal with the most likely and easiest to check conditions first.

WARNING

Isolate a failed transmitter from its pressure source as soon as possible. Pressure that may be present could cause death or serious injury to personnel if the transmitter is disassembled or ruptures under pressure.

Model 1151 Alphaline® Pressure Transmitters

TABLE 5-1. Troubleshooting Symptoms and Corrective Action.

Symptom	Potential Source	Corrective Action
High Output	Primary Element	Check for restrictions at primary element.
	Impulse Piping	Check for leaks or blockage. Ensure that blocking valves are fully open. Check for entrapped gas in liquid lines and for liquid in dry lines. Ensure that the density of fluid in impulse lines is unchanged. Check for sediment in transmitter process flanges.
	Power Supply	Check the power supply output voltage at the transmitter.
	Transmitter electronics	Make sure that post connectors are clean. If the electronics are still suspect, substitute new electronics.
	Sensing Element	The sensing element is not field repairable and must be replaced if found to be defective. See "Transmitter Disassembly" later in this section for instructions on disassembly. Check for obvious defects, such as punctured isolating diaphragm or fill fluid loss, and contact Rosemount North American Response Center at 1-800-THE-RSMT (1-800-654-7768).
Erratic Output	Loop Wiring	Check for adequate voltage to the transmitter. Check for intermittent shorts, open circuits and multiple grounds. <div style="border: 1px solid black; padding: 5px; text-align: center;"> <p>⚠ CAUTION</p> <p>Do not use higher than the specified voltage to check the loop, or damage to the transmitter electronics may result.</p> </div>
	Process Pulsation	Adjust Damping
	Transmitter Electronics	Make sure the post connectors are clean. If the electronics are still suspect, substitute new electronics.
	Impulse Piping	Check for entrapped gas in liquid lines and for liquid in dry lines.

TABLE 5-1. (continued).

Symptom	Potential Source	Corrective Action
Low Output or No Output	Primary Element	Check the insulation and condition of primary element. Note any changes in process fluid properties that may affect output.
	Loop Wiring	<p>Check for adequate voltage to the transmitter. Check the milliamp rating of the power supply against the total current being drawn for all transmitters being powered. Check for shorts and multiple grounds. Check for proper polarity at the signal terminal. Check loop impedance. Check whether the transmitter is in multidrop mode, thus locking the output at 4 mA.</p> <div style="border: 1px solid black; padding: 5px; text-align: center;"> <p>⚠ CAUTION</p> <p>Do not use higher than the specified voltage to check the loop, or damage to the transmitter electronics may result.</p> </div> <p>Check wire insulation to detect possible shorts to ground.</p>
	Impulse Piping	<p>Ensure that the pressure connection is correct. Check for leaks or blockage. Check for entrapped gas in liquid lines. Check for sediment in the transmitter process flange. Ensure that blocking valves are fully open and that bypass valves are tightly closed. Ensure that density of the fluid in the impulse piping is unchanged.</p>
	Sensing Element	<p>The sensing element is not field repairable and must be replaced if found to be defective. See "Transmitter Disassembly" later in this section for instructions on disassembly. Check for obvious defects, such as punctured isolating diaphragm or fill fluid loss, and contact Rosemount North American Response Center at 1-800-THE-RSMT (1-800-654-7768).</p>
Transmitter Does Not Calibrate Properly	Pressure Source/Correction	<p>Check for restrictions or leaks. Check for proper leveling or zeroing of the pressure source. Check weights/gauge to ensure proper pressure setting. Determine if the pressure source has sufficient accuracy.</p>
	Meter	Determine if the meter is functioning properly.
	Power Supply	Check the power supply output voltage at transmitter.
	Transmitter Electronics	<p>Make sure the post connectors are clean. If electronics are still suspect, substitute with new electronics.</p>
	Sensing Element	<p>The sensing element is not field repairable and must be replaced if found to be defective. See "Transmitter Disassembly" later in this section for instructions on disassembly. Check for obvious defects, such as punctured isolating diaphragm or fill fluid loss, and contact Rosemount North American Response Center at 1-800-THE-RSMT (1-800-654-7768).</p>

TRANSMITTER DISASSEMBLY

Read the following information carefully before you disassemble a transmitter. General information concerning the process sensor body, electrical housing, and a procedure for their separation follow. Figure 5-1 shows an exploded view of the transmitter.

WARNING

The following performance limitations may inhibit efficient or safe operation. Critical applications should have appropriate diagnostic and backup systems in place.

Pressure transmitters contain an internal fill fluid. It is used to transmit the process pressure through the isolating diaphragms to the pressure sensing element. In rare cases, oil leak paths in oil-filled pressure transmitters can be created. Possible causes include: physical damage to the isolator diaphragms, process fluid freezing, isolator corrosion due to an incompatible process fluid, etc.

A transmitter with an oil fill fluid leak can continue to perform normally for a period of time. Sustained oil loss will eventually cause one or more of the operating parameters to exceed published specifications while a small drift in operating point output continues. Symptoms of advanced oil loss and other unrelated problems include:

- Sustained drift rate in true zero and span or operating point output or both
- Sluggish response to increasing or decreasing pressure or both
- Limited output rate or very nonlinear output or both
- Change in output process noise
- Noticeable drift in operating point output
- Abrupt increase in drift rate of true zero or span or both
- Unstable output
- Output saturated high or low

WARNING

Explosion can cause death or serious injury. Do not remove the instrument cover in explosive atmospheres when the circuit is alive.

WARNING

Explosions can cause death or serious injury. Do not break the housing seal in explosive environments. Breaking the housing seal invalidates the explosion-proof housing rating.

Electrical connections are located in a compartment identified as **TERMINAL SIDE** on the nameplate. The signal and test terminals are accessible by unscrewing the cover on the terminal side. The terminals to the housing must not be removed, or the housing seal between compartments will be broken. (Not applicable to R1 and R2 Options.)

Process Sensor Body Removal

Be aware of the following guidelines:

- The transmitter should be removed from service before disassembling the sensor body.
- Process flanges can be detached by removing the four large bolts.

CAUTION

Do not scratch, puncture, or depress the isolating diaphragms. Damaging the isolating diaphragms can inhibit transmitter performance.

- Isolating diaphragms may be cleaned with a soft rag, mild cleaning solution, and clear water rinse.

CAUTION

Do not use chlorine or acid solutions to clean the diaphragms. Damaging the isolating diaphragms can inhibit transmitter performance.

- Flange adapters and process flanges may be rotated or reversed for mounting convenience.

FIGURE 5-1. Differential Pressure (DP) Transmitter Exploded View.

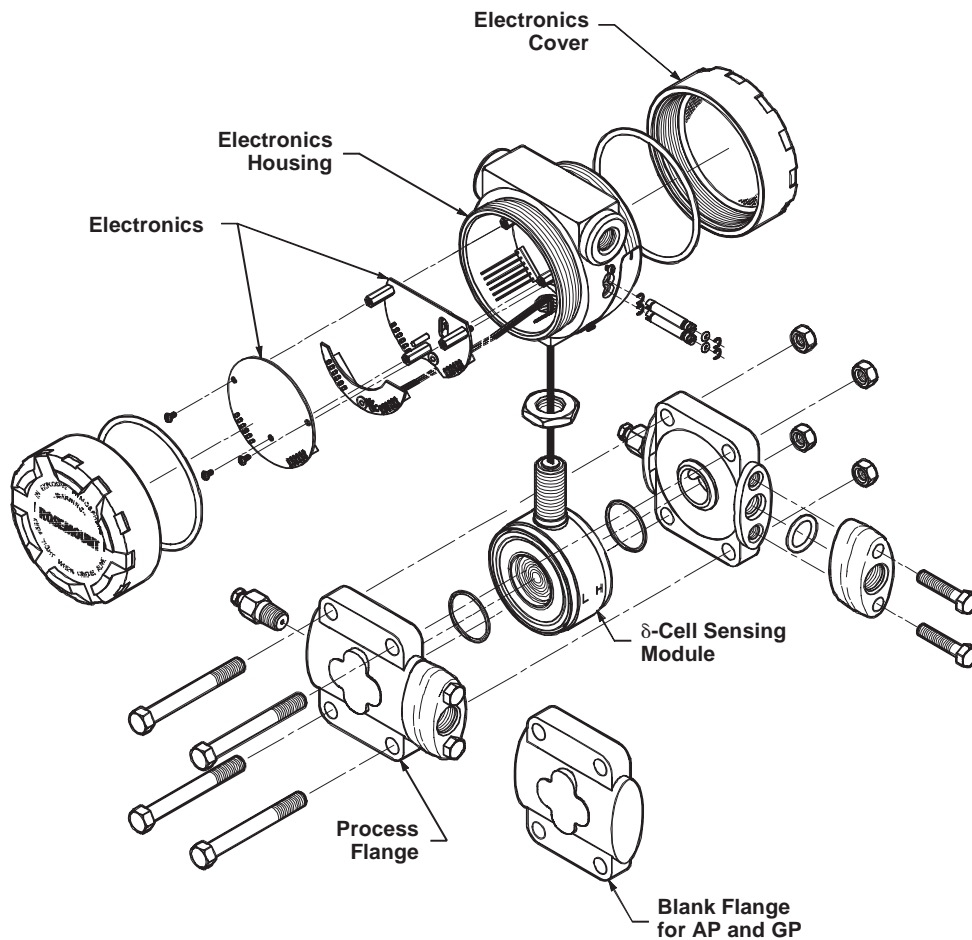

Removing the Sensor from the Electrical Housing

1. Disconnect the power source from the transmitter.
2. Unscrew the cover on the terminal side of the transmitter.
3. Remove the screws and unplug the electronics; see Figure 5-2.
4. Loosen the lock nut.
5. Remove the standoffs.

⚠ CAUTION

Do not damage the isolating diaphragms when unscrewing the sensor module. Damaging the isolating diaphragms can inhibit transmitter performance.

6. Unscrew the sensing module from the electronics housing, being careful not to damage the sensor leads. Carefully pull the header assembly board through the hole. The threaded connection has a sealing compound on it and must be broken loose.

The sensing module is a welded assembly and cannot be further disassembled.

FIGURE 5-2. Removal of Electronics.

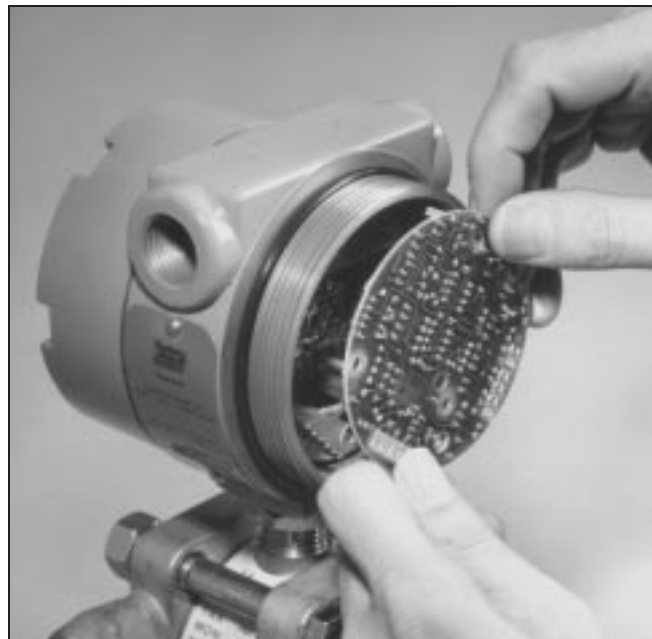

1151-029AB

Sensor Module Checkout

The sensor module is not field repairable and must be replaced if found to be defective. If no obvious defect is observed (such as a punctured isolating diaphragm or fill fluid loss), the sensor module can be checked as follows.

1. Carefully pull the header assembly board off of the post connectors. Rotate the board 180 degrees about the axis formed by the connecting leads. The sensor module and electronics housing can remain attached for checkout.

NOTE

Do not touch the transmitter housing when checking resistances, or a faulty reading can result.

2. Check the resistance between the sensor module housing and pins one through four. This checks the resistance between both capacitor plates and the sensing diaphragm, which is grounded to the housing. This resistance should be greater than 10 M Ω .
3. Check the resistance between pin eight and the sensor module to ensure that the module is grounded. Resistance should be zero.

NOTE

The above procedure does not completely test the sensor module. If circuit board replacement does not correct the abnormal condition, and no other problems are obvious, replace the sensor module.

FIGURE 5-3. Header Board Connections.

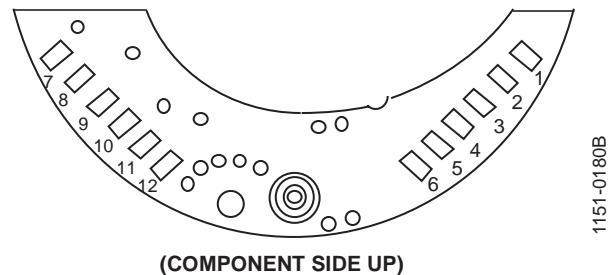

REASSEMBLY PROCEDURE

Follow these procedures carefully to ensure proper reassembly.

Preliminary Precaution

Inspect all O-rings and replace if necessary. Lightly grease with silicone oil to ensure a good seal. Use halocarbon grease for inert fill options.

⚠ WARNING

Explosions can cause death or serious injury. Both transmitter covers must be fully engaged to meet explosion-proof requirements.

Connecting the Electrical Housing to the Sensor

1. Insert the header assembly board through the electronics housing.
2. Use a sealing compound (*Loctite 222 - Small Screw Threadlocker*) on the threads of the sensor module to ensure a watertight seal on the housing.
3. Screw the sensor module into the electrical housing making sure that the threads are fully engaged. Be careful not to damage or twist the sensor leads.
4. Align the sensor module with the high and low pressure sides oriented for convenient installation.
5. Tighten the lock nut.

Backup Ring and O-ring Installation

All HP transmitters and GP Range 9 and 0 transmitters require metal backup rings to ensure O-ring integrity. Figure 5-4 on page 5-8 illustrates the position and orientation of the metal backup rings. (Backup rings are not required on AP or DP transmitters or GP Range 3-8 transmitters.)

FIGURE 5-4. Detail Showing Process O-ring and Backup Ring Installation of Module Seal for Model 1151HP and GP Range 9 (GP Range 0 Requires Only One O-ring and Backup O-ring).

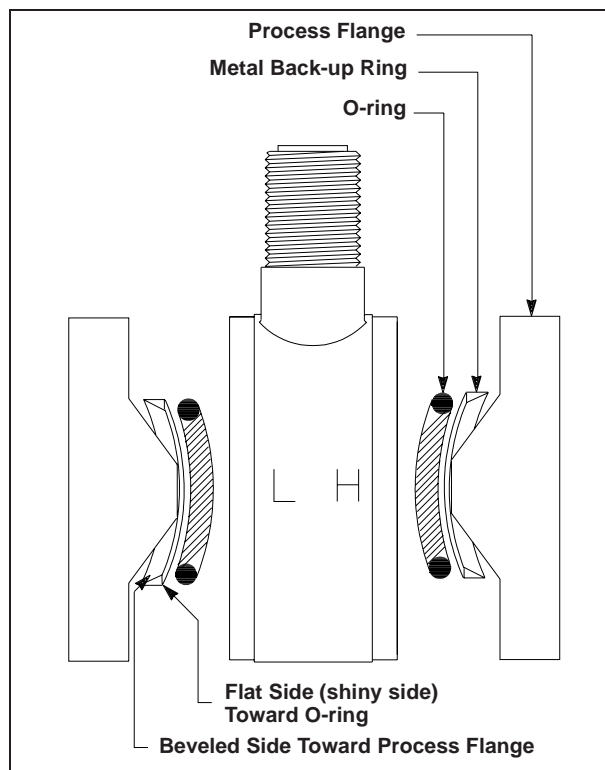

1151-0983A01A

NOTE

Handle the backup ring carefully, as it is fragile. Examine the ring carefully. One side is beveled, while the other side is flat. The flat side appears more shiny when viewed from above.

1. Clean the sealing surfaces carefully.
2. Place the module on a flat surface, “H” side up.
3. Place the greased flange O-ring around the isolator and push it into the cavity.

⚠ WARNING

Process leaks can cause death or serious injury. An incorrectly installed backup ring can destroy the o-ring and cause process leaks. Install the backup ring using the following procedure.

4. For all HP transmitters and GP transmitters Ranges 9 and 0, place the backup ring, shiny side down, on top of the O-ring. This places the flat side of the backup ring against the O-ring.
5. Carefully place the flange on top of the module, beveled side down so that the beveled flange surface mates with the beveled surface of the backup ring.
6. Keeping the flange and module together, turn them over so the “L” side is up. Repeat Steps 3 through 5. As before, the flat side of the backup ring must rest against the O-ring.
7. Insert the four flange bolts.
8. Tighten the nuts finger tight, making sure the flanges remain parallel. The transmitter may now be moved without disturbing the O-rings.
 - a. Tighten one bolt until the flanges seat.
 - b. Torque down the bolt diagonally across.
 - c. Torque down the first bolt.
 - d. Torque down the two remaining bolts.
 - e. Inspect the flange-to-sensor seating to be sure that the flanges are not cocked.
 - f. Check that all four bolts are tightened to approximately 33 ft-lb (39 Nm).
9. Recalibrate the transmitter.

NOTE

If the Model 1151 Range 3 transmitter sensor module serial number is below 2,900,000, it must be temperature cycled whenever changing or rebolting flanges.

Optional Plug-in Meters

The optional indicating meters available for Rosemount Model 1151 transmitters are listed in **Section 4 Options**. Please be aware of the following information while assembling the meter assembly. Refer to Table 6-6 on page 6-13 for part references.

- The meter may be rotated in 90-degree increments for convenient reading.

WARNING

Explosions can cause death or serious injury. Do not disassemble the glass in the meter cover in explosive atmospheres. Disassembling the glass in the meter cover invalidates the explosion-proof meter rating.

- If the meter cover is removed for any reason, be sure the O-ring is in place between the cover and housing before reattachment. To maintain an explosion-proof condition, the glass in the meter cover must not be disassembled for any reason.

RETURN OF MATERIAL

To expedite the return process, call the Rosemount North American Response Center using our 800-654-RSMT (7768) toll-free number. This center, available 24 hours a day, will assist you with any needed information or materials.

The center will ask for product model and serial numbers, and will provide a Return Material Authorization (RMA) number. For safety reasons, the center will also ask for the name of the process material the product was last exposed to.

WARNING

Exposure to hazardous substances can cause death or serious injury. If a hazardous substance is identified, a Material Safety Data Sheet (MSDS), required by law to be available to people exposed to specific hazardous substances, must be included with the returned goods.

The North American Response Center will detail the additional information and procedures necessary to return goods exposed to hazardous substances.

Specifications and Reference Data

FUNCTIONAL SPECIFICATIONS

Service

Liquid, gas, and vapor applications.

Ranges

Minimum span equals the upper range limit (URL) divided by rangedown. Rangedown varies with the output code. See Table 6-1.

Outputs

Code E, Analog

4–20 mA dc, linear with process pressure.

Code G, Analog

10–50 mA dc, linear with process pressure.

Code J, Analog

4–20 mA dc, square root of differential input pressure between 4 and 100% of input. Linear with differential input pressure between 0 and 4% of input.

Code L, Low Power

0.8 to 3.2 V dc, linear with process pressure.

Code M, Low Power

1 to 5 V dc, linear with process pressure.

TABLE 6-1. Rangeability.

Output Code	Minimum Span	Maximum Span
E, G, J	URL/6	URL
L	URL/1.1	URL
M	URL/2	URL

TABLE 6-2. Model 1151 Transmitter Range Availability by Model (URL = Upper Range Limit).

Range Code	Model 1151 Ranges (URL)	DP	HP	GP	AP
3	30 inH ₂ O (7.46 kPa)	•	NA	•	NA
4	150 inH ₂ O (37.3 kPa)	•	•	•	•
5	750 inH ₂ O (186.4 kPa)	•	•	•	•
6	100 psi (689.5 kPa)	•	•	•	•
7	300 psi (2068 kPa)	•	•	•	•
8	1,000 psi (6895 kPa)	•	NA	•	•
9	3,000 psi (20684 kPa)	NA	NA	•	NA
0	6,000 psi (41369 kPa)	NA	NA	•	NA

Model 1151 Alphaline® Pressure Transmitters

TABLE 6-3. Model 1151 Output Code Availability.

Code	Model 1151 Output Options/Damping	DP	HP	GP	DP/GP/Seals	AP
E	4–20 mA, linear, analog/variable	•	•	•	•	•
G	10–50 mA, linear, analog/variable	•	•	•	•	•
J ⁽¹⁾	4–20 mA, square root, analog/variable	•	•	NA	NA	NA
L	0.8 to 3.2 V, linear, low power/fixd	•	•	•	•	•
M	1 to 5 V, linear, low power/fixd	•	•	•	•	•

(1) Available with Ranges 3–5.

Power Supply

External power supply required. Transmitter operates on:

12 to 45 V dc with no load for Output Codes E and J.

30 to 85 V dc with no load for Output Code G.

5 to 12 V dc for Output Code L.

8 to 14 V dc for Output Code M.

Where:

FIGURE 6-1. Power Supply Load Limitations.

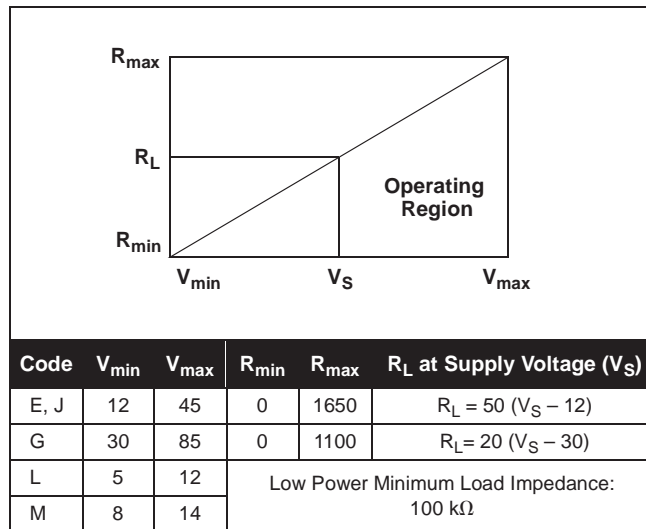

NOTE

For CSA Approvals (codes E and J), $V_{max} = 42.4$ V dc.

Current Consumption (Low Power Only) Under Normal Operating Conditions

Output Code L

1.5 mA dc.

Output Code M

2.0 mA dc.

Span and Zero

Output Codes E, G, J, L, and M

Span and zero are continuously adjustable.

Hazardous Locations Certifications

Stainless steel certification tag is provided.

Factory Mutual (FM) Approvals

FM Explosion proof tag is standard. Appropriate tag will be substituted if optional certification is selected.

Default Explosion proof: Class I, Division 1, Groups B, C, D.
Dust-Ignition proof: Class II, Division 1, Groups E, F, G; Class III, Division 1. Indoor and outdoor use (NEMA 4X). Factory Sealed.

I5 Intrinsically Safe: Class I, Division 1, Groups A, B, C, D; Class II, Division 1, Groups E, F, G; Class III, Division 1 when connected in accordance with Rosemount drawing 01151-0214 (See Appendix A).
Non-incendive: Class I, Division 2, Groups A, B, C, D.

K5 Explosion proof, Intrinsic Safety, and Non-incendive combination.

Canadian Standards Association (CSA) Approvals

E6 Explosion proof for Class I, Division 1, Groups C and D.
Dust-Ignition proof: Class II, Division 1, Groups E, F, and G; Class III, Division 1. Suitable for Class I, Division 2, Groups A, B, C, D. CSA Enclosure type 4X. Factory sealed.

I6 Intrinsically Safe: Class I, Division 1, Groups A, B, C, D; Temperature Code T2D when connected in accordance with Rosemount drawing 01151-2575. (See Appendix A.)

C6 Explosion proof, Division 2, and Intrinsic Safety combination.

K6 Combined **E6**, **I6**, **E8**, and **I8**.

Standards Association of Australia (SAA)**E7 Flameproof**

Ex d IIB + H₂ T6.
Class I, Zone 1.

Dust-Ignition proof

DIP T6.
Class II.

Special Conditions: For transmitters having NPT or PG cable entry threads, an appropriate flame proof thread adaptor shall be used to facilitate application of certified flame proof cable glands.

I7 Intrinsically Safe

Ex ia IIC T6 ($T_{amb} = 40\text{ }^{\circ}\text{C}$).
Ex ia IIC T5 ($T_{amb} = 70\text{ }^{\circ}\text{C}$).
Class I, Zone 0. (See Appendix A.)

Special Conditions: Observe electrical connection parameters when installing transmitter.

N7 Type N

Ex n IIC T6 ($T_{amb} = 40\text{ }^{\circ}\text{C}$).
Ex n IIC T5 ($T_{amb} = 70\text{ }^{\circ}\text{C}$).
Class I, Zone 2.

Special Conditions: The equipment must be connected to a supply voltage which does not exceed the rated voltage. The enclosure endcaps must be correctly fitted whilst the equipment is energized.

CESI/CENELEC Approvals

E8 Flame proof

EEx d IIC T6.

I8 Intrinsically Safe

EEx ia IIC T6 ($T_{amb} = 40\text{ }^{\circ}\text{C}$); $P_{max} = 0.75\text{ W}$.

EEx ia IIC T5 ($T_{amb} = 55\text{ }^{\circ}\text{C}$); $P_{max} = 1.00\text{ W}$.

EEx ia IIC T5 ($T_{amb} = 80\text{ }^{\circ}\text{C}$); $P_{max} = 1.00\text{ W}$.

Special Conditions: When transient protection terminal options R1 or R9 are installed, the transmitter must be supplied from a galvanically isolated intrinsic safety barrier.

BASEEFA/CENELEC Approvals

I1 Intrinsically Safe

EEx ia IIC T5 ($T_{amb} = 40\text{ }^{\circ}\text{C}$).

EEx ia IIC T4 ($T_{amb} = 80\text{ }^{\circ}\text{C}$).

N1 Type N

Output Code E

Ex N II T6; $U_n = 28\text{ V}$.

Output Code F

Ex N II T5; $U_n = 45\text{ V}$.

Output Code J

Ex N II T5; $U_n = 30\text{ V}$; $I_n = 30\text{ mA}$.

Other Approvals

The Rosemount 1151 carries many other national and international approvals/certifications. Consult factory for other available options.

TABLE 6-4. Intrinsic Safety Entity Parameters.

BASEEFA (United Kingdom)	CESI (Italy)	SAA (Australia)
$U_{max,in} = 28\text{ V dc}$ $I_{max,in} = 120\text{ mA}$	$U_i = 30\text{ V}$ $I_i = 200\text{ mA}$ $P_i = 0.75\text{ W (T6)}$ $P_i = 1.0\text{ W (T4 and T5)}$ $C_i = 0.01\text{ }\mu\text{F}$ $L_i = 20\text{ }\mu\text{F}$	$U_i = 30\text{ V}$ $I_i = 200\text{ mA}$ $C_i = 0.034\text{ }\mu\text{F}$ $L_i = 20\text{ }\mu\text{H}$

Zero Elevation and Suppression**Output Codes E and G**

Zero elevation and suppression must be such that the lower range value is greater than or equal to the (-URL) and the upper range value is less than or equal to the (+URL). The calibrated span must be greater than or equal to the minimum span.

Output Code J

Zero is adjustable up to 10% of the calibrated flow span.

Output Code L

Zero is adjustable $\pm 10\%$ of URL and span is adjustable from 90 to 100% of URL.

Output Code M

Zero is adjustable $\pm 50\%$ of URL and span is adjustable from 50 to 100% of URL.

Temperature Limits**Electronics Operating**

Code E -40 to 200 °F (-40 to 93 °C).

Code G, L, M -20 to 200 °F (-29 to 93 °C).

Code J -20 to 150 °F (-29 to 66 °C).

Sensing element operating

Silicone fill: -40 to 220 °F (-40 to 104 °C).

Inert fill: 0 to 160 °F (-18 to 71 °C).

NOTE

When specifying Option Codes W4 and W6, sensing element operating temperatures are 32 to 200 °F (0 to 93 °C) for silicone fill and 32 to 160 °F (0 to 71 °C) for inert fill.

Storage

Codes E, G, L, M: -60 to 250 °F (-51 to 121 °C).

Code J: -60 to 180 °F (-51 to 82 °C).

Static Pressure Limits

Transmitters operate within specifications between the following limits:

Model 1151DP

0.5 psia (3.45 kPa) to 2,000 psig (13790 kPa).

Model 1151HP

0.5 psia (3.45 kPa) to 4,500 psig (31027 kPa).

Model 1151AP

0 psia to the URL.

Model 1151GP

0.5 psia (3.45 kPa) to the URL.

Overpressure Limits

Transmitters withstand the following limits without damage:

Model 1151DP

0 psia to 2,000 psig (0 to 13790 kPa).

Model 1151HP

0 psia to 4,500 psig (0 to 31027 kPa).

Model 1151AP

0 psia to 2,000 psia (0 to 13790 kPa).

Model 1151GP

Ranges 3–8: 0 psia to 2,000 psig (0 to 13790 kPa).

Range 9: 0 psia to 4,500 psig (31027 kPa).

Range 0: 0 psia to 7,500 psig (51710 kPa).

Burst Pressure Limit

All models: 10,000 psig (68.95 MPa) burst pressure on the flanges.

Humidity Limits

0 to 100% relative humidity.

Volumetric Displacement

Less than 0.01 in³ (0.16 cm³).

Damping

Numbers given are for silicone fill fluid at room temperature. The minimum time constant is 0.2 seconds (0.4 seconds for Range 3). Inert-filled sensor values would be slightly higher.

Output Codes E and G

Time constant continuously adjustable between minimum and 1.67 seconds.

Output Code J

Time constant continuously adjustable between minimum and 1.0 second.

Output Codes L, M

Damping is fixed at minimum time constant.

Turn-on Time

Maximum of 2.0 seconds with minimum damping. Low power output is within 0.2% of steady state value within 200 ms after application of power.

**PERFORMANCE
SPECIFICATIONS**

(Zero-based calibrated ranges, reference conditions, silicone oil fill, 316 SST isolating diaphragms.)

Accuracy

Output Codes E, G, L, and M

±0.2% of calibrated span for Model 1151DP Ranges 3 through 5.

All other ranges and transmitters, ±0.25% of calibrated span.

Output Code J

±0.25% of calibrated span.

Stability

Output Codes E and G

±0.2% of URL for six months for Ranges 3 through 5. (±0.25 for all other ranges.)

Output Codes J, L, and M

±0.25% of URL for six months.

Temperature Effect**Output Code E, G, L, and M**

[-20 to 200 °F (-29 to 93 °C)]

For Ranges 4 through 0Zero Error = $\pm 0.5\%$ URL per 100 °F.Total Error = $\pm(0.5\%$ URL + 0.5% of calibrated span) per 100 °F (56 °C); double the effect for Range 3.**Output Code J**The total output effect, whether at zero or full scale, including zero and span errors is $\pm 1.5\%$ of URL per 100 °F (56 °C), or $\pm 2.5\%$ of URL per 100 °F (56 °C) for Range 3.**Static Pressure Effect****DP Transmitters****Zero Error:** $\pm 0.25\%$ of URL for 2,000 psi (13790 kPa) or $\pm 0.5\%$ for Range 3, correctable through rezeroing at line pressure.**Span Error:** Correctable to $\pm 0.25\%$ of input reading per 1,000 psi (6895 kPa), or to $\pm 0.5\%$ for Range 3. For Output Code J, the span error is correctable to $\pm 0.125\%$ of output reading per 1,000 psi, or to $\pm 0.25\%$ for Range 3.**HP Transmitters****Zero Error:** $\pm 2.0\%$ of URL for 4,500 psi (31027 kPa), correctable through rezeroing at line pressure.**Span Error:** Correctable to $\pm 0.25\%$ of input reading per 1,000 psi (6895 kPa).For Output Code J, the span error is correctable to $\pm 0.125\%$ of output reading per 1,000 psi (6895 kPa), or to $\pm 0.25\%$ for Range 3.**Vibration Effect**

0.05% of URL per g to 200 Hz in any axis.

Power Supply Effect**Output Codes E, G, and J**

Less than 0.005% of output span per volt.

Output Codes L, M

Output shift of less than 0.05% of URL for a 1 V dc power supply shift.

Load Effect**Output Codes E, G, and J**

No load effect other than the change in power supplied to the transmitter.

Output Codes L, MLess than 0.05% of URL effect for a change in load from 100 k Ω to infinite ohms.**Short Circuit Condition (Output Codes L and M only)**

No damage to the transmitter will result when the output is shorted to common or to power supply positive (limit 12 V).

EMI/RFI Effect

Output shift of less than 0.1% of span when tested to IEC 801-3 from 20 to 1000 MHz and for field strengths up to 30 V/m. (Output Code J is 0.1% of flow span.)

Mounting Position EffectZero shift of up to 1 inH₂O (0.24 kPa) that can be calibrated out. Range 3 transmitters with Output Code J should be installed with the diaphragm in the vertical plane.

**PHYSICAL
SPECIFICATIONS
(STANDARD
CONFIGURATION)**

Wetted Materials

Isolating Diaphragms

316L SST, Hastelloy C-276, Monel, gold-plated Monel, or Tantalum. See ordering table for availability per model type.

Drain/Vent Valves

316 SST, Hastelloy C, or Monel. See ordering table for availability per model type.

Process Flanges and Adaptors

Plated carbon steel, 316 SST, Hastelloy C, or Monel. See ordering table for availability per model type.

Wetted O-rings

Viton (other materials also available). With gold-plated Monel diaphragms (diaphragm Code _6), special fluorocarbon O-rings are supplied.

Non-wetted Materials

Fill Fluid

Silicone oil or inert fill.

Bolts and Bolting Flange (GP and AP only)

Plated carbon steel.

Electronics Housing

Low-copper aluminium. NEMA 4X. IP 65, IP 66.

Cover O-rings

Buna-N.

Paint

Polyurethane.

Process Connections

¼-18 NPT on 2.125-in. (54-mm) centers on flanges for Ranges 3, 4, and 5.

¼-18 NPT on 2.188-in. (56-mm) centers on flanges for Ranges 6 and 7.

¼-18 NPT on 2.250-in. (57-mm) centers on flanges for Range 8.

½-14 NPT on adaptors.

For Ranges 3, 4, and 5, flange adaptors can be rotated to give centers of 2.0 in. (51 mm), 2.125 in. (54 mm), or 2.250 in. (57 mm).

Electrical Connections

½-14 NPT conduit entry with screw terminals and integral test jacks compatible with miniature banana plugs (Pomona 2944, 3690, or equivalent).

Weight

12 lb (5.4 kg) for AP, DP, GP, and HP transmitters, excluding options.

FIGURE 6-2. Dimensional Drawing for Model 1151 Transmitter.

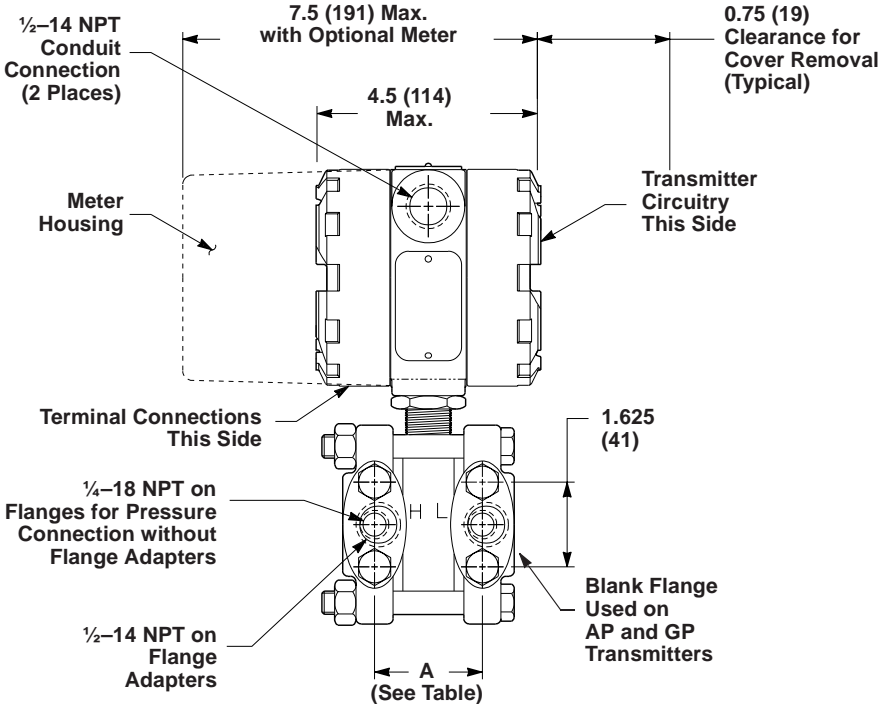

Range	Flange Distance "A" Center to Center	
	inches	mm
3, 4, 5	2.125	54
6, 7	2.188	56
8	2.250	57
9	2.281	58
0	2.328	59

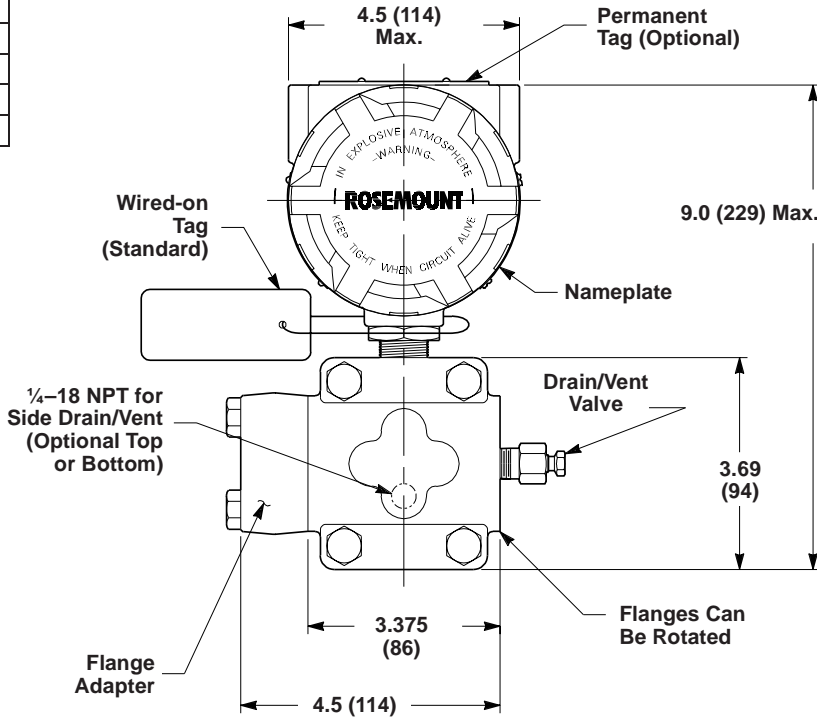

NOTE
Dimensions are in inches (millimeters).

1151-1151A,B05A

Model 1151 Alhaline® Pressure Transmitters

TABLE 6-5. Model 1151 Model Number Table.

					• = Applicable	— =Not Applicable			
Model	Transmitter Type (select one)				DP	HP	GP	AP	
1151DP	Differential Pressure Transmitter				•	—	—	—	
1151HP	Differential Pressure Transmitter for High Line Pressures				—	•	—	—	
1151GP	Gage Pressure Transmitter				—	—	•	—	
1151AP	Absolute Pressure Transmitter				—	—	—	•	
Code	Pressure Ranges (URL) (select one)				DP	HP	GP	AP	
3	30 inH ₂ O (7.46 kPa)				•	—	•	—	
4	150 inH ₂ O (37.3 kPa)				•	•	•	•	
5	750 inH ₂ O (186.4 kPa)				•	•	•	•	
6	100 psi (689.5 kPa)				•	•	•	•	
7	300 psi (2068 kPa)				•	•	•	•	
8	1,000 psi (6895 kPa)				•	—	•	•	
9	3,000 psi (20684 kPa)				—	—	•	—	
0	6,000 psi (41369 kPa)				—	—	•	—	
Code	Transmitter Output (select one)				DP	HP	GP	AP	
E	4–20 mA, Linear, Analog/Variable Damping				•	•	•	•	
G	10–50 mA, Linear, Analog/Variable Damping				•	•	•	•	
J	4–20 mA, Square Root, Analog/Variable Damping				•	•	—	—	
L	0.8 to 3.2 V, Linear, Low Power/Fixed Damping				•	•	•	•	
M	1 to 5 V, Linear, Low Power/Fixed Damping				•	•	•	•	
Code	MATERIALS OF CONSTRUCTION ⁽¹⁾				DP	HP	GP ⁽²⁾	AP ⁽²⁾	
	Flanges/Adaptors	Drain/Vents	Diaphragms	Fill Fluid					
52	Nickel-plated Carbon Steel	316 SST	316L SST	Silicone	•	•	•	•	
53	Nickel-plated Carbon Steel	316 SST	Hastelloy C	Silicone	•	•	•	•	
54	Nickel-plated Carbon Steel	316 SST	Monel	Silicone	•	•	•	•	
55	Nickel-plated Carbon Steel	316 SST	Tantalum	Silicone	•	—	•	—	
56	Nickel-plated Carbon Steel	316 SST	Gold-plated Monel	Silicone	•	—	•	—	
12	Plated Carbon Steel	316 SST	316L SST	Silicone	•	•	•	•	
22	316 SST	316 SST	316L SST	Silicone	•	•	•	•	
23	316 SST	316 SST	Hastelloy C	Silicone	•	•	•	•	
24	316 SST	316 SST	Monel	Silicone	•	•	•	•	
25	316 SST	316 SST	Tantalum	Silicone	•	—	•	—	
26	316 SST	316 SST	Gold-plated Monel	Silicone	•	—	•	—	
33	Hastelloy C	Hastelloy C	Hastelloy C	Silicone	•	•	•	•	
34	Hastelloy C	Hastelloy C	Monel	Silicone	•	—	•	—	
35	Hastelloy C	Hastelloy C	Tantalum	Silicone	•	—	•	—	
36	Hastelloy C	Hastelloy C	Gold-plated Monel	Silicone	•	—	•	—	
43	Monel	Monel	Hastelloy C	Silicone	•	•	•	•	
44	Monel	Monel	Monel	Silicone	•	•	•	•	
45	Monel	Monel	Tantalum	Silicone	•	—	•	—	
46	Monel	Monel	Gold-plated Monel	Silicone	•	—	•	—	
73 ⁽³⁾	316 SST	Hastelloy C	Hastelloy C	Silicone	•	•	•	•	
83 ⁽³⁾	Nickel-plated Carbon Steel	Hastelloy C	Hastelloy C	Silicone	•	•	•	•	
5A	Nickel-plated Carbon Steel	316 SST	316L SST	Inert	•	—	•	—	
5B	Nickel-plated Carbon Steel	316 SST	Hastelloy C	Inert	•	—	•	—	
5C	Nickel-plated Carbon Steel	316 SST	Monel	Inert	•	—	•	—	
5D	Nickel-plated Carbon Steel	316 SST	Tantalum	Inert	•	—	•	—	
1A	Plated Carbon Steel	316 SST	316L SST	Inert	•	—	•	—	
2A	316 SST	316 SST	316L SST	Inert	•	—	•	—	
2B	316 SST	316 SST	Hastelloy C	Inert	•	—	•	—	
2D	316 SST	316 SST	Tantalum	Inert	•	—	•	—	
3B	Hastelloy C	Hastelloy C	Hastelloy C	Inert	•	—	•	—	
3D	Hastelloy C	Hastelloy C	Tantalum	Inert	•	—	•	—	
4B	Monel	Monel	Hastelloy C	Inert	•	—	•	—	
4C	Monel	Monel	Monel	Inert	•	—	•	—	
4D	Monel	Monel	Tantalum	Inert	•	—	•	—	
7B ⁽³⁾	316 SST	Hastelloy C	Hastelloy C	Inert	•	—	•	—	
8B ⁽³⁾	Nickel-plated Carbon Steel	Hastelloy C	Hastelloy C	Inert	•	—	•	—	

(1) Bolts and conduit plugs are plated carbon steel.

(2) On GP and AP transmitters, the low-side flange is plated carbon steel. For a stainless-steel low-side flange, order process connections Option Code D6.

(3) These selections meet NACE material recommendations per MR01-75.

TABLE 6-5. (continued).

Code	Mounting Brackets (optional – select one)	DP	HP	GP	AP
B1	Bracket, 2-in. Pipe Mount	•	•	•	•
B2	Bracket, Panel Mount	•	•	•	•
B3	Bracket, Flat, 2-in. Pipe Mount	•	•	•	•
B4	B1 Bracket with 316 SST Bolts	•	•	•	•
B5	B2 Bracket with 316 SST Bolts	•	•	•	•
B6	B3 Bracket with 316 SST Bolts	•	•	•	•
B7	316 SST B1 Bracket with 316 SST Bolts	•	•	•	•
B9	316 SST B3 Bracket with 316 SST Bolts	•	•	•	•
Code	Meters (optional – select one)	DP	HP	GP	AP
M1 ⁽¹⁾	Analog Scale, Linear Meter, 0–100%	•	•	•	•
M2 ⁽²⁾	Analog Scale, Square Root Meter, 0–100% Flow	•	•	—	—
M3 ⁽¹⁾	Analog Scale, Linear Meter, Special Scale	•	•	•	•
M4 ⁽³⁾	LCD Display, Linear Meter, 0–100% scale, User Selectable	•	•	•	•
M6 ⁽²⁾	Analog Scale, Square Root Meter, 0–10√	•	•	—	—
M7 ⁽³⁾	LCD Display, Linear Meter, Special Configuration	•	•	•	•
M8 ⁽²⁾⁽³⁾	LCD Display Square Root Meter, 0–100% Flow	•	•	—	—
M9 ⁽²⁾⁽³⁾	LCD Display, Square Root Meter, 0–10√	•	•	—	—
Code	Certifications (optional – select one)	DP	HP	GP	AP
	NOTE FM explosion-proof approval is standard.				
I5 ⁽⁴⁾	Factory Mutual (FM) Non-incendive and Intrinsic Safety Approval	•	•	•	•
K5 ⁽⁴⁾	Combination of E5 and I5.	•	•	•	•
E6	Canadian Standards Association (CSA) Explosion-Proof Approval, 42.4 V dc max.	•	•	•	•
I6 ⁽⁴⁾	Canadian Standards Association (CSA) Intrinsic Safety Approval, 42.4 V dc max.	•	•	•	•
C6 ⁽⁴⁾	Combination of I6 and E6; CSA Explosion-Proof and Intrinsic Safety Approval (Requires 42.4 V dc max. power supply)	•	•	•	•
K6 ⁽⁴⁾	CSA/CENELEC Explosion-Proof and Intrinsic Safety Approval	•	•	•	•
E7	Standards Association of Australia (SAA) Flameproof Certification	•	•	•	•
I7 ⁽⁶⁾	Standards Association of Australia (SAA) Intrinsic Safety Certification	•	•	•	•
N7	Standards Association of Australia (SAA) Type N Certification	•	•	•	•
E8	CESI/CENELEC Flameproof Certification	•	•	•	•
I8 ⁽⁵⁾	CESI/CENELEC Intrinsic Safety Certification	•	•	•	•
I1 ⁽⁶⁾	BASEEFA/CENELEC Intrinsic Safety Certification	•	•	•	•
N1 ⁽⁷⁾	BASEEFA Type N Certification	•	•	•	•
IC ⁽⁶⁾	Schweizerischer Elektrotechnischer Verein (SEV) Intrinsic Safety Certification	•	•	•	•
Code	Housing (optional – select one)	DP	HP	GP	AP
H1	SST Non-wetted Parts on Transmitter without Meter	•	•	•	•
H2	SST Non-wetted Parts on Transmitter with Meter	•	•	•	•
H3	SST Housing, Covers, Conduit Plug, Lock-nut, Without Meter	•	•	•	•
H4	SST Housing, Covers, Conduit Plug, Lock-nut, With Meter	•	•	•	•
J1 ⁽⁸⁾	Aluminum Housing, JIS G ½ Female Electrical Connection	•	•	•	•
Code	Terminal Blocks (optional – select one)	DP	HP	GP	AP
R1 ⁽⁹⁾	Integral Transient Protection (Only Available with E Electronics)	•	•	•	•
Code	Bolts for Flanges and Adaptors (optional – select one)	DP	HP	GP	AP
L3	ASTM A193-B7 Flange and Adaptor Bolts	•	•	•	•
L4	316 SST Flange and Adaptor Bolts	•	•	•	•
L5	ASTM A193-B7M Flange and Adaptor Bolts	•	•	•	•

(1) Not available with Output Codes L or M, or Option Codes Zx, V2, or V3.
 (2) Not available with Output Codes J, L, M, or Option Codes Zx, V2, or V3.
 (3) Not available with Output Codes G, L, M, or Option Codes Zx, V2, or V3.
 (4) Not available with Output Code G or option Zx.
 (5) Not available with Output Codes G, J, L, M, S, or option Zx.
 (6) Not available with Output Codes G, J, L, M, or option Zx.
 (7) Not available with Output Codes G, L, M, or option Zx.
 (8) Valid with E4 approval, JIS Explosion-Proof. No other approvals apply.
 (9) Not available with I1.

Model 1151 Alvaline® Pressure Transmitters

TABLE 6-5. (continued).

Code	Process Connections (optional) ⁽¹⁾	DP	HP	GP	AP
D1	Side Drain/Vent, Top	•	•	•	•
	316 SST	•	•	•	•
	Hastelloy	•	•	•	•
	Monel	•	•	•	•
D2	Side Drain/Vent, Bottom	•	•	•	•
	316 SST	•	•	•	•
	Hastelloy	•	•	•	•
	Monel	•	•	•	•
D3	Process Adaptors Deleted	•	•	•	•
	316 SST	•	•	•	•
	Hastelloy	•	•	•	•
	Monel	•	•	•	•
D9 ⁽²⁾	JIS Rc ¼ flanges and Rc ½ adapters	•	•	•	•
	316 SST	•	•	•	•
	Hastelloy	•	•	•	•
	Monel	•	•	•	•
D6	316 SST Low Side Blank Flange	—	—	•	•
K1 ⁽³⁾	Kynar insert, ¼–18 NPT	•	—	•	•
K2 ⁽³⁾	Kynar insert, ½–14 NPT	•	—	•	•
S1 ⁽⁴⁾	Attachment of One Remote Seal - See PDS 00813-0100-4016 for Ordering Information	•	—	•	—
S2 ⁽⁴⁾	Attachment of Two Remote Seals - See PDS 00813-0100-4016 for Ordering Information	•	—	—	—
S4 ⁽⁵⁾	Attachment of Integral Orifice Assembly - See PDS 00813-0100-4686 for Ordering Information	•	•	—	—
Code	Wetted O-ring Material	DP	HP	GP	AP
W2	Buna-N	•	•	•	•
W3	Ethylene-Propylene	•	•	•	•
W4	Aflas	•	•	•	•
W6 ⁽⁶⁾	Spring-loaded Teflon	•	—	•	•
Code	Procedures	DP	HP	GP	AP
P1	Hydrostatic Testing, 150% Maximum Working Pressure (125% for GP 10)	•	•	•	•
P2	Cleaning for Special Service	•	•	•	—
P3 ⁽⁷⁾	Cleaning for < 1 PPM Chlorine/Fluorine	•	•	•	•
P4	Calibrate at Line Pressure	•	•	—	•
P5	Calibrate at Specific Temperature	•	•	•	•
P7 ⁽⁸⁾	Improved Temperature Coefficient	•	•	•	•
P8 ⁽⁹⁾	Calibrate to 0.1% Accuracy	•	•	•	—
Code	Outputs	DP	HP	GP	AP
V1	Reverse Output	—	—	•	—
V2 ⁽¹⁰⁾	4–20 mV Test Signal	•	•	•	•
V3 ⁽¹⁰⁾	20–100 mV Test Signal	•	•	•	•
Z1 ⁽¹¹⁾	4-wire, 0–20 mA Output	•	•	•	•
Z2 ⁽¹¹⁾	4-wire, 0–16 mA Output	•	•	•	•
Z3 ⁽¹¹⁾	4-wire, 0–10 mA Output	•	•	•	•
Typical Model Number: 1151DP 4 S 52 B3 M1					

(1) Allowable combinations are: D1-D3-D6, D2-D3-D6, and D6-S1.

(2) Valid with E4, JIS Explosion Proof approval when used in combination with J1. No other approvals apply.

(3) The Maximum working pressure on this option is 300 psig.

(4) This options may only be used on ranges 4 through 8.

(5) This option has a maximum static pressure rating of 3,000 psi, and is available for factory

assembly only without associated piping and is available only for ranges 2, 3, 4, and 5.

(6) Contains a Hastelloy spring that is wetted by the process; consult factory for Teflon O-ring without a spring (ranges 3-8 only).

(7) Flourolube grease on wetted O-rings.

(8) Not available on range 10: limited to 1,500 psi on range 9.

(9) Available only with stainless steel isolators and for span of 10 inH₂O and greater; available only with Output Codes E, G, L, or M; not available on AP or DR transmitters.

(10) Not available with Output Codes L or M.

(11) Not available with Option Codes Mx, Vx, Ix, or Ex, or Output Codes G, L, M.

TABLE 6-6. Model 1151 Spare Parts List.

Electronics – One spare part recommended for every 25 transmitters.		
Part Description	Item No.	Part Number
E Output Code, 4–20 mA dc Amplifier Circuit Board Calibration Circuit Board	4	01151-0137-0001
	6	01151-0139-0001
G Output Code, 10–50 mA dc Amplifier Circuit Board Calibration Circuit Board	4	01151-0597-0001
	6	01151-0139-0001
J Output Code, 4–20 mA dc, Square Root Amplifier Circuit Board Calibration Circuit Board	4	01151-0378-0001
	6	01151-0377-0001
L Output Code, 0.8–3.2 V, Low Power Amplifier Circuit Board Calibration Circuit Board	4	01151-0507-0001
	6	01151-0509-0001
M Output Code Amplifier Circuit Board Calibration Circuit Board	4	01151-0507-0002
	6	01151-0509-0002
Sensor Modules (Silicon Fill)–One spare part recommended for every 50 transmitters.		
Part Description	Item No.	Part Number
Range 3 DP, GP (URL=30 inH₂O) 316L SST <i>Hastelloy C-276</i> <i>Monel</i> Tantalum Gold-plated <i>Monel</i>	19	01151-0011-0032
		01151-0011-0033
		01151-0011-0034
		01151-0011-0035
		01151-0011-0036
		01151-0011-0036
Range 4 DP, GP (URL=150 inH₂O) 316L SST <i>Hastelloy C-276</i> <i>Monel</i> Tantalum Gold-plated <i>Monel</i>	19	01151-0011-0042
		01151-0011-0043
		01151-0011-0044
		01151-0011-0045
		01151-0011-0046
		01151-0011-0046
Range 4 HP (URL=150 inH₂O) 316L SST <i>Hastelloy C-276</i> <i>Monel</i>	19	01151-0112-0042
		01151-0112-0043
		01151-0112-0044
Range 4 AP (URL=11 inHgA) 316L SST <i>Hastelloy C-276</i> <i>Monel</i>	19	01151-0054-0042
		01151-0054-0043
		01151-0054-0044

(continued on next page)

Model 1151 Alphaline® Pressure Transmitters

TABLE 6-6. (continued).

Sensor Modules (Silicon Fill)—One spare part recommended for every 50 transmitters.		
Part Description	Item No.	Part Number
Range 5 DP, GP (URL=750 inH₂O) 316L SST <i>Hastelloy C-276</i> <i>Monel</i> Tantalum Gold-plated <i>Monel</i>	19	01151-0011-0052 01151-0011-0053 01151-0011-0054 01151-0011-0055 01151-0011-0056
Range 5 HP (URL=750 inH₂O) 316L SST <i>Hastelloy C-276</i> <i>Monel</i>	19	01151-0112-0052 01151-0112-0053 01151-0112-0054
Range 5 AP (URL=55 inHgA) 316L SST <i>Hastelloy C-276</i> <i>Monel</i>	19	01151-0054-0052 01151-0054-0053 01151-0054-0054
Range 6 DP (URL=100 psid) 316L SST <i>Hastelloy C-276</i> <i>Monel</i> Tantalum Gold-plated <i>Monel</i>	19	01151-0041-0062 01151-0041-0063 01151-0041-0064 01151-0041-0065 01151-0041-0066
Range 6 GP (URL=100 psig) 316L SST <i>Hastelloy C-276</i> <i>Monel</i> Tantalum Gold-plated <i>Monel</i>	19	01151-0041-0162 01151-0041-0163 01151-0041-0164 01151-0041-0165 01151-0041-0166
Range 6 HP (URL=100 psid) 316L SST <i>Hastelloy C-276</i> <i>Monel</i>	19	01151-0112-0062 01151-0112-0063 01151-0112-0064
Range 6 AP (URL=100 psia) 316L SST <i>Hastelloy C-276</i> <i>Monel</i>	19	01151-0054-0062 01151-0054-0063 01151-0054-0064
Range 7 DP (URL=300 psid) 316L SST <i>Hastelloy C-276</i> <i>Monel</i> Tantalum Gold-plated <i>Monel</i>	19	01151-0041-0072 01151-0041-0073 01151-0041-0074 01151-0041-0075 01151-0041-0076
Range 7 GP (URL=300 psig) 316L SST <i>Hastelloy C-276</i> <i>Monel</i> Tantalum Gold-plated <i>Monel</i>	19	01151-0041-0172 01151-0041-0173 01151-0041-0174 01151-0041-0175 01151-0041-0176

(continued on next page)

TABLE 6-6. (continued).

Sensor Modules (Silicon Fill) (continued) –One spare part recommended for every 50 transmitters.		
Part Description	Item No.	Part Number
Range 7 HP (URL=300 psid) 316L SST <i>Hastelloy C-276</i> <i>Monel</i>	19	01151-0112-0072 01151-0112-0073 01151-0112-0074
Range 7 AP (URL=300 psia) 316L SST <i>Hastelloy C-276</i> <i>Monel</i>	19	01151-0054-0072 01151-0054-0073 01151-0054-0074
Range 8 DP (URL=1,000 psid) 316L SST <i>Hastelloy C-276</i> <i>Monel</i> Tantalum Gold-plated <i>Monel</i>	19	01151-0041-0082 01151-0041-0083 01151-0041-0084 01151-0041-0085 01151-0041-0086
Range 8 GP (URL=1,000 psig) 316L SST <i>Hastelloy C-276</i> <i>Monel</i> Tantalum Gold-plated <i>Monel</i>	19	01151-0041-0182 01151-0041-0183 01151-0041-0184 01151-0041-0185 01151-0041-0186
Range 8 AP (URL=1,000 psia) 316L SST <i>Hastelloy C-276</i> <i>Monel</i>	19	01151-0054-0082 01151-0054-0083 01151-0054-0084
Range 9 GP (URL=3,000 psig) 316L SST <i>Hastelloy C-276</i> <i>Monel</i>	19	01151-0112-0192 01151-0112-0193 01151-0112-0194
Range 10 GP (URL=6,000 psig) 316L SST <i>Hastelloy C-276</i> <i>Monel</i>	19	01151-0112-0002 01151-0112-0003 01151-0112-0004

(continued on next page)

Model 1151 Alphaline® Pressure Transmitters

TABLE 6-6. (continued).

Sensor Modules (Inert Fill)—One spare part recommended for every 50 transmitters.		
Part Description	Item No.	Part Number
Range 3 DP, GP (URL=30 inH₂O) 316L SST <i>Hastelloy C-276</i> <i>Monel</i> Tantalum Gold-plated <i>Monel</i>	19	01151-0230-0032 01151-0230-0033 01151-0230-0034 01151-0230-0035 01151-0230-0036
Range 4 DP, GP (URL=150 inH₂O) 316L SST <i>Hastelloy C-276</i> <i>Monel</i> Tantalum Gold-plated <i>Monel</i>	19	01151-0230-0042 01151-0230-0043 01151-0230-0044 01151-0230-0045 01151-0230-0046
Range 5 DP, GP (URL=750 inH₂O) 316L SST <i>Hastelloy C-276</i> <i>Monel</i> Tantalum Gold-plated <i>Monel</i>	19	01151-0230-0052 01151-0230-0053 01151-0230-0054 01151-0230-0055 01151-0230-0056
Range 6 DP (URL=100 psid) 316L SST <i>Hastelloy C-276</i> <i>Monel</i> Tantalum	19	01151-0230-0062 01151-0230-0063 01151-0230-0064 01151-0230-0065
Range 6 GP (URL=100 psig) 316L SST <i>Hastelloy C-276</i> <i>Monel</i> Tantalum	19	01151-0230-0162 01151-0230-0163 01151-0230-0164 01151-0230-0165
Range 7 DP (URL=300 psid) 316L SST <i>Hastelloy C-276</i> <i>Monel</i> Tantalum	19	01151-0230-0072 01151-0230-0073 01151-0230-0074 01151-0230-0075
Range 7 GP (URL=300 psig) 316L SST <i>Hastelloy C-276</i> <i>Monel</i> Tantalum	19	01151-0230-0172 01151-0230-0173 01151-0230-0174 01151-0230-0175
Range 8 DP (URL=1,000 psid) 316L SST <i>Hastelloy C-276</i> <i>Monel</i> Tantalum	19	01151-0230-0082 01151-0230-0083 01151-0230-0084 01151-0230-0085
Range 8 GP (URL=1,000 psig) 316L SST <i>Hastelloy C-276</i> <i>Monel</i> Tantalum	19	01151-0230-0182 01151-0230-0183 01151-0230-0184 01151-0230-0185

(continued on next page)

TABLE 6-6. (continued).

Housings, Covers, Flanges, And Valves – One spare part recommended for every 25 transmitters.		
Part Description	Item No.	Part Number
Electronics Housing	7	01151-0060-0007
Electronics Cover	1	01151-1045-0001
Process Flange Nickel-plated Carbon Steel Plated Carbon Steel 316 SST <i>Hastelloy C-276</i> <i>Monel</i>	17	01151-0236-0005 01151-0236-0001 01151-0213-0002 01151-0213-0004 01151-0213-0003
Process Flange for Side Drain/Vent Valve Nickel-plated Carbon Steel Plated Carbon Steel 316 SST <i>Hastelloy C-276</i> <i>Monel</i>		01151-0236-0015 01151-0236-0011 01151-0213-0012 01151-0213-0014 01151-0213-0013
Blank Flange Plated Carbon Steel	23	90043-0046-0001
Flange Adapter Nickel-plated Carbon Steel Plated Carbon Steel 316 SST <i>Hastelloy C-276</i> <i>Monel</i>	21	01151-0211-0005 90001-0033-0001 01151-0211-0002 01151-0211-0004 01151-0211-0003
DP and HP Valve Stem and Seat, 316 SST ⁽¹⁾	14,15	01151-0028-0022
GP and AP Valve Stem and Seat, 316 SST ⁽¹⁾	14,15	01151-0028-0012
DP and HP Valve Stem and Seat, 316 SST, <i>Hastelloy C</i> ⁽¹⁾	14,15	01151-0028-0023
GP and AP Valve Stem and Seat, 316 SST, <i>Hastelloy C</i> ⁽¹⁾	14,15	01151-0028-0013
DP and HP Valve Stem and Seat, 316 SST, <i>Monel</i> ⁽¹⁾	14,15	01151-0028-0024
GP and AP Valve Stem and Seat, 316 SST, <i>Monel</i> ⁽¹⁾	14,15	01151-0028-0014
Plug, 316 SST (used with side drain/vent)		C50246-0002
Plug, <i>Hastelloy C</i> (used with side drain/vent)		01151-0063-0001
Plug, <i>Monel</i> (used with side drain/vent)		01151-0063-0002
Hardware—One spare part recommended for every 50 transmitters.		
Part Description	Item No.	Part Number
Adjustment Kit Adjustment Screw O-ring for Adjustment Screw Retaining Ring	10 11 12	01151-0029-0001
O-ring for Adjustment Screw (pkg of 12)	11	01151-0032-0001
O-ring for Electronics Cover (pkg of 12)	2	01151-0033-0003
O-ring for Process Flange, <i>Viton</i> (pkg of 12)	18	01151-0034-0020
O-ring for Process Flange, <i>Viton</i> and Backup Ring (pkg of 4)	18	01151-0034-0014
O-ring for Process Flange, Buna-N (pkg of 12)	18	01151-0034-0002
O-ring for Process Flange, Buna-N and Backup Ring (pkg of 4)	18	01151-0034-0016
O-ring for Process Flange, Ethylene-propylene (pkg of 12)	18	01151-0034-0004
O-ring for Process Flange, Ethylene-propylene and Backup Ring (pkg of 4)	18	01151-0034-0015
O-ring for Process Flange, <i>Aflas</i> (pkg of 4) ⁽²⁾	18	01151-0034-0019
O-ring for Flange Adapter, <i>Viton</i> (pkg of 12)	20	01151-0035-0009

(continued on next page)

(1) Package contains quantity required for one transmitter.

(2) Kit contains enough parts for two differential or four gage/absolute transmitters. Backup rings are included.

Model 1151 Alphaline® Pressure Transmitters

TABLE 6-6. (continued).

Hardware (continued)—One spare part recommended for every 50 transmitters.		
Part Description	Item No.	Part Number
O-ring for Flange Adapter, Buna-N (pkg of 12)	20	01151-0035-0002
O-ring for Flange Adapter, Ethylene-propylene (pkg of 12)	20	01151-0035-0004
O-ring for Flange Adapter, <i>Aflas</i> (pkg of 12) ⁽¹⁾	20	01151-0035-0008
O-ring for Flange Adapter, <i>Teflon</i> with <i>Hastelloy C</i> Spring (pkg of 4)	20	01151-0034-0021
Electronics Assembly Hardware⁽²⁾		01151-0030-0001
Standoff	8	
Standoff	5	
Screw	9	
Screw	3	
Locknut		
DP and HP Flange Kits, Carbon Steel⁽¹⁾		01151-0031-0001 (DP & HP Ranges 3–7) or
Bolt for Flange Adapter	22	
Bolt for Process Flange	13	01151-0031-0034
Nut for Process Flange	16	(DP Range 8)
GP and AP Flange Kits, Carbon Steel⁽¹⁾		01151-0031-0002 (AP Ranges 4–7, GP Ranges 3–7)
Bolt for Flange Adapter, Carbon Steel	22	
Bolt for Process Flange, Carbon Steel	13	
Nut for Process Flange, Carbon Steel	16	or 01151-0031-0035 (AP & GP Range 8) or 01151-0031-0003 (GP Range 9) or 01151-0031-0019 (GP Range 0)
DP and HP Flange Kits, 316 SST⁽¹⁾		01151-0031-0023 (DP & HP Ranges 3–7) or
Bolt for Flange Adapter	22	
Bolt for Process Flange	13	01151-0031-0038
Nut for Process Flange	16	(DP Range 8)
GP and AP Flange Kits, 316 SST⁽¹⁾		01151-0031-0024 (AP Ranges 4–7, GP Ranges 3–7)
Bolt for Flange Adapter, 316 SST	22	
Bolt for Process Flange, 316 SST	13	
Nut for Process Flange, 316 SST	16	or 01151-0031-0039 (AP & GP Range 8) or 01151-0031-0025 (GP Range 9) or 01151-0031-0026 (GP Range 0)
DP and HP Flange Kits, ANSI 193-B7⁽¹⁾		01151-0031-0012 (DP & HP Ranges 3–7) or
Bolt for Flange Adapter	22	
Bolt for Process Flange	13	01151-0031-0036
Nut for Process Flange	16	(DP Range 8)
GP and AP Flange Kits, ANSI 193-B7⁽¹⁾		01151-0031-0013 (AP Ranges 4–7, GP Ranges 3–7)
Bolt for Flange Adapter, ANSI 193-B7	22	
Bolt for Process Flange, ANSI 193-B7	13	
Nut for Process Flange, ANSI 193-B7	16	or 01151-0031-0037 (AP & GP Range 8) or 01151-0031-0014 (GP Range 9) or 01151-0031-0022 (GP Range 0)

(continued on next page)

(1) Part number is for package of 12 O-rings—only two required per transmitter.

(2) Package contains quantity required for one transmitter.

TABLE 6-6. (continued).

Indicating Meters		
Part Description	Item No.	Part Number
Analog Meter Kit, 4–20 mA dc, Linear Scale ⁽¹⁾		01151-1046-0007
Analog Meter Kit, 4–20 mA dc, Square Root, 0-100% Flow		01151-1046-0009
Analog Meter Kit, 10–50 mA dc, Linear Scale ⁽¹⁾		01151-1046-0011
Analog Meter Kit, 10–50 mA dc, Square Root, 0–100% Flow		01151-1046-0013
I.S. Approved Analog Meter Kit, 4–20 mA dc, Linear Scale ⁽¹⁾		01151-2615-0007
I.S. Approved Analog Meter Kit, 4–20 mA dc, Square Root, 0-100% Flow		01151-2615-0009
I.S. Approved Analog Meter Kit, 10–50 mA dc, Linear Scale ⁽¹⁾		01151-2615-0011
I.S. Approved Analog Meter Kit, 10–50 mA dc, Square Root, 0–100% Flow		01151-2615-0013
LCD Meter Kit, Linear, 0–100% Flow		01151-1046-0019
LCD Meter Kit, Square Root, 0–100% Flow		01151-1046-0021
Analog Meter, 4–20 mA dc, Linear Scale		01151-0687-0004
Analog Meter, 4–20 mA dc, Square Root, 0–100% Flow		01151-0687-0005
Analog Meter, 4–20 mA dc, Square Root, 0–10 √		01151-0687-0008
Analog Meter, 10–50 mA dc, Linear Scale		01151-0687-0006
Analog Meter, 10–50 mA dc, Square Root, 0–100% Flow		01151-0687-0007
Analog Meter, 10–50 mA dc, Square Root, 0–10 √		01151-0687-0009
I.S. Approved Analog Meter, 4–20 mA dc, Linear Scale		01151-2614-0004
I.S. Approved Analog Meter, 4–20 mA dc, Square Root, 0–100% Flow		01151-2614-0005
I.S. Approved Analog Meter, 4–20 mA dc, Square Root, 0–10 √		01151-2614-0008
I.S. Approved Analog Meter, 10–50 mA dc, Linear Scale		01151-2614-0006
I.S. Approved Analog Meter, 10–50 mA dc, Square Root, 0–100% Flow		01151-2614-0007
I.S. Approved Analog Meter, 10–50 mA dc, Square Root, 0–10 √		01151-2614-0009
Special Scale for Analog Meter		See note (1) below
LCD Meter, Linear, 0–100%		01151-1300-1000
LCD Meter, Square Root, 0–100% Flow		01151-1300-1001
LCD Meter, Special Configuration ⁽²⁾		01151-1300-1000
LCD Meter Engineering Unit Labels		01151-1351-1001
Mounting Hardware and Cover Assembly Kit		01151-1046-0005
Mounting Hardware Kit		01151-1046-0006
Cover Assembly Kit		01151-1047-0001
O-ring for Cover (pkg of 12)		01151-0033-0003
Mounting Brackets		
Part Description	Item No.	Part Number
B1—Right-angle Bracket for 2-in. Pipe Mounting		01151-0036-0001
B2—Right-angle Bracket for Panel Mounting		01151-0036-0004
B3—Flat Bracket for 2-in. Pipe Mounting		01151-0036-0005
B4—Bracket for 2-in. Pipe with Series 300 SST Bolts		01151-0036-0003
B5—Bracket for Panel with Series 300 SST Bolts		01151-0036-0006
B6—Flat Bracket for 2-in. Pipe with Series 300 SST Bolts		01151-0036-0007
B7—316 SST B1 Bracket with 316 SST Bolts		01151-0036-0021
B9—316 SST B3 Bracket with 316 SST Bolts		01151-0036-0022

(1) Meter kit includes meter, mounting hardware, and cover assembly. For meters with special scaling, order the appropriate meter and specify the scale desired. Mounting hardware and cover assembly must be ordered separately.

(2) To order a meter with a special configuration, order the appropriate meter and indicate configuration desired. To order a special configuration LCD meter kit, order the meter, and the mounting hardware and cover assembly kit separately.

Approval Drawings

Rosemount Drawing 01151-0214, Rev. V, 6 Sheets:
Index of Intrinsically Safe Barrier Systems and Entity Parameters for
444, 1135, 1144, 1151, and 2051 Transmitters and 751 Field Indicators.

Rosemount Drawing 01151-2575, Rev. C, 3 Sheets:
Index of CSA Intrinsically Safe Barrier Systems for Model 1151
Transmitters.

Rosemount Drawing 01151-2576, Rev. C, 2 Sheets:
Entity Drawing: 1151 SAA Intrinsic Safety Configuration.

REVISIONS					
LTR	DESCRIPTION	ECO NO	REV BY	APPR	DATE
P	Change entity parameters (Fm on re-exam) correct 444 CI	637376	WJR	WJR	9/28/90
R	Add 1151 Low Power Barrier System, Model 751 LI to 0	638105		WJR	4/27/90
T	1135, 1144, 1151 LI TO Ø	639039	SVC	WJR	1/23/91
U	1151 LI TO 20; CI .01 AND .034	651426	SVC	WJR	12/11/92
V	751 LI TO Ø	662242		QSE	11/17/94

CONTENTS	
ENTITY APPROVALS	SHEETS 2 THRU 4
APPROVED PARAMETERS	SHEETS 2 THRU 3
CONNECTION DIAGRAMS	SHEET 4

MASTER

APPROVED SOURCES OF SUPPLY	
MFG	MFG PART NO

Material purchased to this Rosemount Specification Control Drawing shall be required to meet all the specifications of this drawing. Any mention of manufacturer's part number within this drawing is for reference only. This is necessary to ensure design control of Rosemount's end product. It is Rosemount's intent to purchase your standard material whenever possible.

SPECIFICATION CONTROL DRAWING

UNLESS OTHERWISE SPECIFIED, DIMENSIONS ARE IN INCHES. TOLERANCES: DECIMALS FRACTIONS .X ± .1 ± 1/32 .XX ± .02 ANGLES .XXX ± .010 ± 2°	PREPARED BY: <i>Nancy Nix</i>	DATE: <i>9/28/90</i>	ROSEMOUNT® Measurement Control Analytical Valves
	CHECKED BY: <i>WJR</i>		
	APPROVED BY Q.C. _____		TITLE: INDEX OF INTRINSICALLY SAFE BARRIER SYSTEMS & ENTITY PARAMETERS FOR 444, 1135, 1144, 1151, & 2051 TRANSMITTERS AND 751 FIELD INDICATORS
	APPROVED BY ENG. <i>WJR</i>	APPROVED BY PURCH. _____	SIZE: A CODE IDENT NO: 04274 DRAWING NO: 01151-0214
FINAL APPROVAL ES _____		SCALE: None U/M: Each SHEET 1 OF 3	

ENTITY CONCEPT APPROVALS

The entity concept allows interconnection of intrinsically safe apparatus to associated apparatus not specifically examined in combination as a system. The approved values of maximum open circuit voltage (V_{OC} or V_T) and maximum short circuit current (I_{SC} or I_T) for the associated apparatus must be less than or equal to the maximum safe input voltage (V_{MAX}) and input current (I_{MAX}) of the intrinsically safe apparatus. In addition, the approved maximum allowable connected capacitance (C_A) and inductance (L_A) of the associated apparatus must be greater than the maximum unprotected internal capacitance (C_I) and inductance (L_I) of the intrinsically safe apparatus. The approved entity concept parameters are as follows:

Model 444

Class I, Div. 1, Groups A and B

$$V_{MAX} = 40V$$

$$I_{MAX} = 165 \text{ mA}$$

$$C_I = 0.044\mu F$$

$$L_I = 0$$

$$V_{OC} \text{ or } V_T \text{ is less than or equal to } 40V$$

$$I_{SC} \text{ or } I_T \text{ is less than or equal to } 165 \text{ mA}$$

$$C_A \text{ is greater than } 0.044\mu F$$

$$L_A \text{ is greater than } 0$$

Class I, Div. 1, Groups C and D

$$V_{MAX} = 40V$$

$$I_{MAX} = 225 \text{ mA}$$

$$C_I = 0.044\mu F$$

$$L_I = 0$$

$$V_{OC} \text{ or } V_T \text{ is less than or equal to } 40V$$

$$I_{SC} \text{ or } I_T \text{ is less than or equal to } 225 \text{ mA}$$

$$C_A \text{ is greater than } 0.044\mu F$$

$$L_A \text{ is greater than } 0$$

Model 751

Class I, Div. 1, Groups A and B

$$V_{MAX} = 40V$$

$$I_{MAX} = 165 \text{ mA}$$

$$C_I = 0$$

$$L_I = 0$$

$$V_{OC} \text{ or } V_T \text{ is less than or equal to } 40V$$

$$I_{SC} \text{ or } I_T \text{ is less than or equal to } 165 \text{ mA}$$

$$C_A \text{ is greater than } 0$$

$$L_A \text{ is greater than } 0$$

Class I, Div. 1, Groups C and D

$$V_{MAX} = 40V$$

$$I_{MAX} = 225 \text{ mA}$$

$$C_I = 0$$

$$L_I = 0$$

$$V_{OC} \text{ or } V_T \text{ is less than or equal to } 40V$$

$$I_{SC} \text{ or } I_T \text{ is less than or equal to } 225 \text{ mA}$$

$$C_A \text{ is greater than } 0$$

$$L_A \text{ is greater than } 0$$

Rosemount Inc. MINNEAPOLIS, MINNESOTA		SIZE A	FSCM. NO.	DRAWING NO. 01151-0214
DR.		SCALE: NONE	WT.	SHEET 2 OF 6
ISSUE				

MASTER

Model and 1151

Class I, Div. 1, Groups A and B

$V_{MAX} = 40V$
 $I_{MAX} = 165\text{ mA}$
 $C_I(1151\text{ Std}) = 0$
 $C_I(\text{Smart } 1151) = 0.024\mu F$
 $C_I(1151\text{ Std w/R Option}) = 0.010\mu F$
 $C_I(1151\text{ Smart w/R_Option}) = 0.034\mu F$
 $L_I(1151\text{ Std}) = 0$
 $L_I(1151\text{ w/R_Option}) = 20\mu H$

V_{OC} or V_T is less than or equal to 40V
 I_{SC} or I_T is less than or equal to 165 mA
 C_A is greater than 0
 C_A is greater than $0.024\mu F$
 C_A is greater than $0.010\mu F$
 C_A is greater than $0.034\mu F$
 L_A is greater than 0
 L_A is greater than $20\mu H$

Class I, Div. 1, Groups C and D

$V_{MAX} = 40V$
 $I_{MAX} = 225\text{ mA}$
 $C_I(1151\text{ Std}) = 0$
 $C_I(\text{Smart } 1151) = 0.024\mu F$
 $C_I(1151\text{ Std w/R Option}) = 0.010\mu F$
 $C_I(1151\text{ Smart w/R_Option}) = 0.034\mu F$
 $L_I(1151\text{ Std}) = 0$
 $L_I(1151\text{ w/R_Option}) = 20\mu H$

V_{OC} or V_T is less than or equal to 40V
 I_{SC} or I_T is less than or equal to 225 mA
 C_A is greater than 0
 C_A is greater than $0.024\mu F$
 C_A is greater than $0.010\mu F$
 C_A is greater than $0.034\mu F$
 L_A is greater than 0
 L_A is greater than $20\mu H$

Model 2051

Class I, Div. 1, Groups A and B

$V_{MAX} = 40V$
 $I_{MAX} = 165\text{ mA}$
 $C_I = 0.012\mu F$
 $L_I = 480\mu H$

V_{OC} or V_T is less than or equal to 40V
 I_{SC} or I_T is less than or equal to 165 mA
 C_A is greater than $0.012\mu F$
 L_A is greater than $480\mu H$

Class I, Div. 1, Groups C and D

$V_{MAX} = 40V$
 $I_{MAX} = 225\text{ mA}$
 $C_I = 0.012\mu F$
 $L_I = 480\mu H$

V_{OC} or V_T is less than or equal to 40V
 I_{SC} or I_T is less than or equal to 225 mA
 C_A is greater than $0.012\mu F$
 L_A is greater than $480\mu H$

Rosemount Inc. MINNEAPOLIS, MINNESOTA		SIZE	FSCM. NO.	DRAWING NO.
		A		01151-0214
DR.		SCALE: NONE	WT.	SHEET 3 OF 6
ISSUE				

Model 1135

Class I, Div. 1, Groups A and B

$V_{MAX} = 40V$

$I_{MAX} = 165 \text{ mA}$

$C_I = 0.008\mu F$

$L_I = 0$

Class I, Div. 1, Groups C and D

$V_{MAX} = 40V$

$I_{MAX} = 225 \text{ mA}$

$C_I = 0.008\mu F$

$L_I = 0$

 V_{OC} or V_T is less than or equal to 40V I_{SC} or I_T is less than or equal to 165 mA C_A is greater than 0.0081F L_A is greater than 0 V_{OC} or V_T is less than or equal to 40V I_{SC} or I_T is less than or equal to 225 mA C_A is greater than 0.0081F L_A is greater than 0**Model 1144**

Class I, Div. 1, Groups A and B

$V_{MAX} = 40V$

$I_{MAX} = 165 \text{ mA}$

$C_I = 0$

$L_I = 0$

Class I, Div. 1, Groups C and D

$V_{MAX} = 40V$

$I_{MAX} = 225 \text{ mA}$

$C_I = 0$

$L_I = 0$

 V_{OC} or V_T is less than or equal to 40V I_{SC} or I_T is less than or equal to 165 mA C_A is greater than 0 L_A is greater than 0 V_{OC} or V_T is less than or equal to 40V I_{SC} or I_T is less than or equal to 225 mA C_A is greater than 0 L_A is greater than 0**MASTER**

Rosemount Inc. MINNEAPOLIS, MINNESOTA		SIZE A	FSCM. NO.	DRAWING NO. 01151-0214
DR.		SCALE: NONE	WT.	SHEET 4 OF 6
ISSUE				

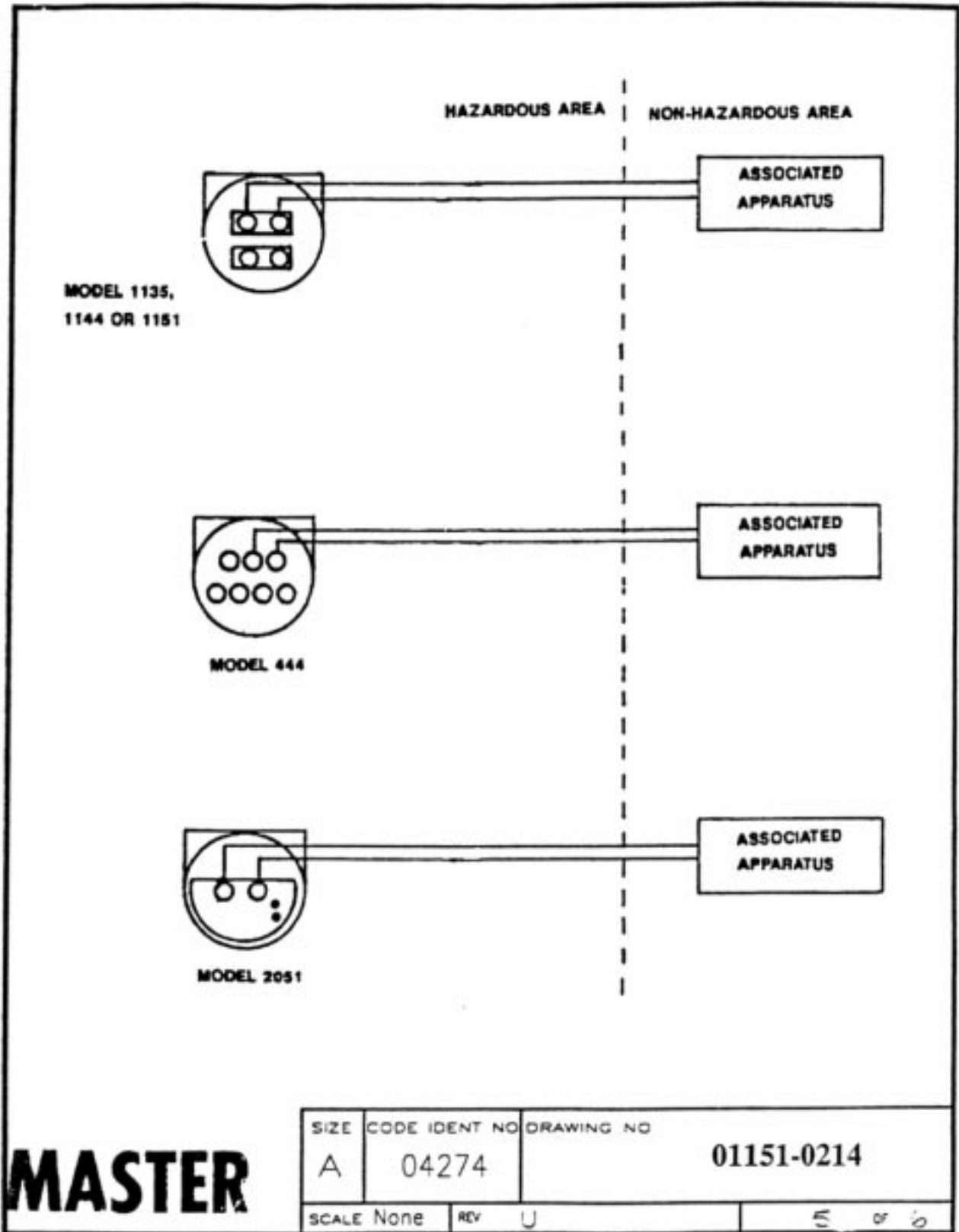

MASTER

SIZE	CODE IDENT NO	DRAWING NO
A	04274	01151-0214
SCALE None	REV U	5 of 6

1151 --- L & M CIRCUIT CONNECTION WITH INTRINSIC SAFETY BARRIERS

HAZARDOUS AREA

NON-HAZARDOUS AREA

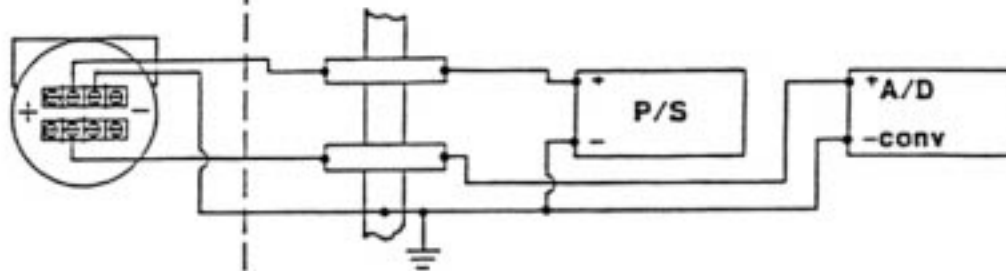

Two Single Channel Barriers

CIRCUIT DIAGRAM 1

(ONLY FOR USE WITH BARRIERS APPROVED IN THIS CONFIGURATION)

HAZARDOUS AREA

NON-HAZARDOUS AREA

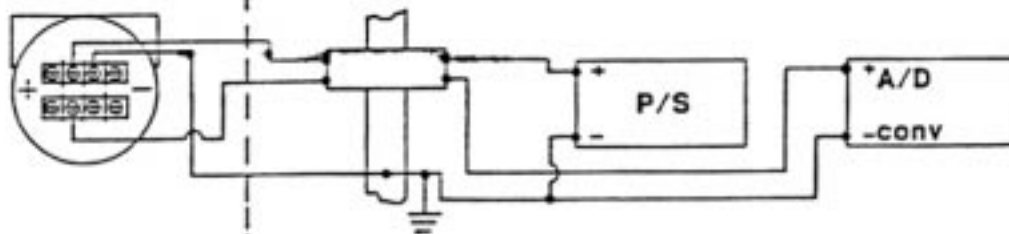

One Dual Channel Barrier

CIRCUIT DIAGRAM 2

MASTER

SIZE	CODE IDENT NO	DRAWING NO
A	04274	01151-0214
SCALE NONE	REV U	c OF 6

PROPRIETARY INFORMATION IS CONTAINED HEREIN AND MUST BE HANDLED ACCORDINGLY BY _____ DATE _____	REVISIONS				
	REV	DESCRIPTION	CHG. NO.	APP'D	DATE
	A	NEW RELEASE	646666	W.C.R.	04/01/92
	B	150 ohms was 120 ohms	650816	J.J.B.	11/13/92
C	150 ohms was 120 ohms (SHT 3)	652195	J.J.B.	1/29/93	

CSA INTRINSICALLY SAFE APPROVAL

Exia
Intrinsically Safe /Securite Intrinseque

THE ROSEMOUNT MODEL 1151 PRESSURE TRANSMITTER IS APPROVED BY CSA AS INTRINSICALLY SAFE FOR THE CLASS I, DIVISION 1 GROUPS AS INDICATED WHEN USED WITH THE BARRIERS AND CONVERTERS LISTED BELOW AND CONNECTED AS SHOWN IN THE ACCOMPANYING DIAGRAMS.

DEVICE	PARAMETERS	APPROVED FOR CLASS I, DIV. 1
CSA Approved Safety Barrier	$\left. \begin{array}{l} 30 \text{ V or less} \\ 330 \text{ ohms or more} \\ \\ 28 \text{ V or less} \\ 300 \text{ ohms or more} \\ \\ 22 \text{ V or less} \\ 180 \text{ ohms or more} \end{array} \right\}$	Groups A, B, C, D
Foxboro Converter 2AS-131-CGB, 3AD-131A CS-E /CGB-A, 2AI-13V-CGB, 3A2-13D CS-E /CGB-A, 2AI-12V-CGB, 3A2-12D CS-E /CGB-A, 2AS-121-CGB, 3A4-12DA CS-E /CGB-A, 3F4-12DA1 CS-E /CGB-A		Groups B, C, D
CSA Approved Safety Barrier	$\left. \begin{array}{l} 30 \text{ V or less} \\ 150 \text{ ohms or more} \end{array} \right\}$	Groups C, D

THIS DRAWING WAS CREATED ON CAD. DRAWING IS ARCHIVED ON MAGNETIC TAPE FOR ECO CHANGES.

UNLESS OTHERWISE SPECIFIED DIMENSIONS IN INCHES. REMOVE ALL BURRS AND SHARP EDGES. MACHINE SURFACE FINISH 125 - TOLERANCES - DECIMALS FRACTIONS .X±.1 ±1/32 .XX±.02 ANGLES .XXX±.010 ±2° DO NOT SCALE PRINT	CONTRACT NO.	<div style="display: flex; justify-content: space-between; align-items: center;"> <div style="font-weight: bold; font-size: 1.2em;">ROSEMOUNT®</div> <div style="font-size: 0.8em;"> Measurement Control Analytical Valves </div> <div style="font-size: 0.8em;"> Rosemount Inc. 12001 Technology Drive Eden Prairie, MN 55344 USA </div> </div> <p style="font-size: 1.2em; margin-top: 10px;">TITLE INDEX OF CSA INTRINSICALLY SAFE BARRIER SYSTEMS FOR MODEL 1151 TRANSMITTERS</p>	
	DR. S.CAPPAUL 03/18/92		SIZE A
	CHK'D W.C.RAUTH 04/01/92		FSCM NO
	APP'D. W.C.RAUTH 04/01/92		WT. _____
APP'D. GOVT.	SCALE N/A	DWG NO. 01151-2575	
		SHEET 1 OF 3	

REVISIONS				
REV	DESCRIPTION	CHG. NO.	APP'D	DATE
C		652195		

MODEL 1151 CIRCUIT CONNECTION WITH BARRIER OR CONVERTER

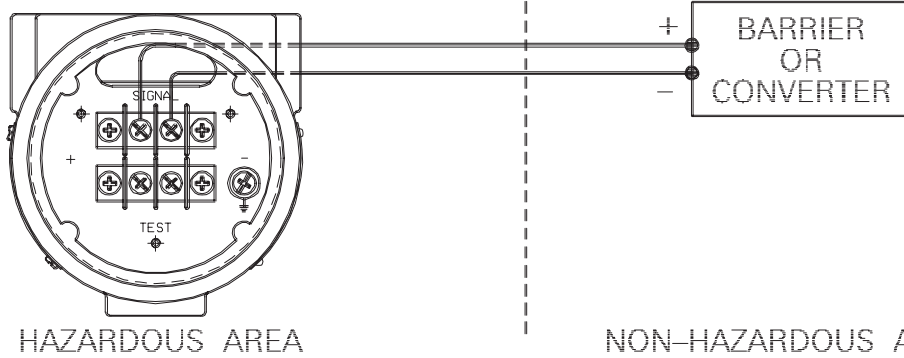

MODEL 1151___L, M CIRCUIT CONNECTION WITH BARRIER(S)

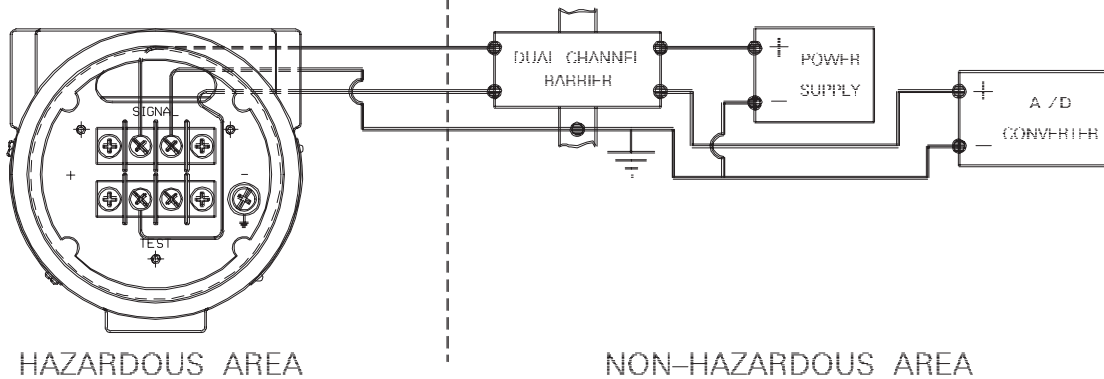
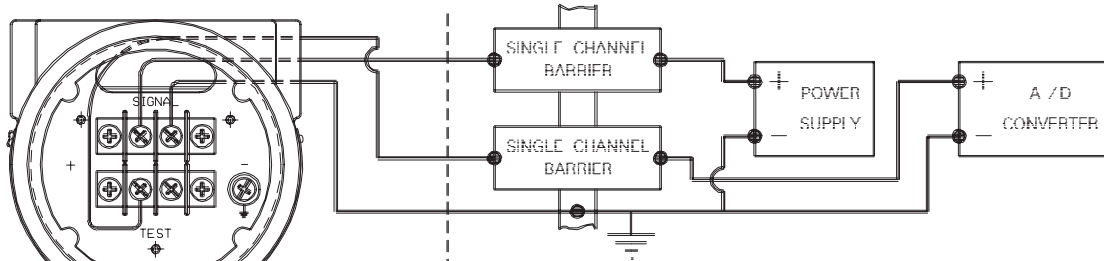

Rosemount Inc.
12001 Technology Drive
Eden Prairie, MN 55344 USA

DR. **S. CAPAUL** 03/18/92

ISSUED

THIS DRAWING WAS CREATED ON CAD. DRAWING IS ARCHIVED ON MAGNETIC TAPE FOR ECO CHANGES.

SIZE	FSCM NO	DWG NO.	01151-2575
A			
SCALE	NONE	WT.	SHEET 2 OF 3

Glossary

Calibration	Operations that adjust for minor effects such as span shift and zero shift. These effects are usually caused by outside influences such as rotating a transmitter, or mounting a transmitter on its side. See Section 2 Installation .
Damping	Output function that increases the response time of the transmitter to smooth the output when there are rapid input variations. See Section 3 Calibration .
Lower Range Limit (LRL)	Lowest value of the measured variable that the transmitter can be configured to measure.
Lower Range Value (LRV)	Lowest value of the measured variable that the analog output of the transmitter is currently configured to measure.
Reranging	Configuration function that changes the transmitter 4 and 20 mA settings. See Section 3 Calibration .
Span	Algebraic difference between the upper and lower range values. See Section 3 Calibration .
Upper Range Limit (URL)	Highest value of the measured variable that the transmitter can be configured to measure.
Upper Range Value (URV)	Highest value of the measured variable that the analog output of the transmitter is currently configured to measure.
Zero Trim	A zero-based, one-point adjustment used in differential pressure applications to compensate for mounting position effects or zero shifts caused by static pressure. See Section 3 Calibration .

A

- Access Requirements 2-3
 - Circuit Side of Electronics Housing 2-3
 - Environmental 2-3
 - Exterior of Electronics Housing 2-3
 - Housing Rotation 2-3
 - Process Flange Orientation 2-3
 - Terminal Side of Electronics Housing 2-3
- Adjustment
 - Damping Adjustment 3-8
 - Linearity Adjustment 3-7
- Ammeter
 - Connecting 2-10
- Analog Meters 4-3
- Approval Drawings A-1
- Approvals
 - Intrinsic Safety Entity Parameters 6-4
- Assembly
 - LCD Meters 4-5

B

- Backup Ring Installation 5-8
- Brackets
 - Mounting Brackets 2-5
 - Mounting Options 2-6
- Bubbler Liquid Level Measurement 2-16
- Bubbler System in Open Vessel 2-16
 - Liquid Level Measurement 2-16

C

- Calibration 3-1
 - Damping Adjustment 3-8
 - Data Flow 3-3
 - Elevated or Suppressed Zeros 3-7
 - Linearity Adjustment 3-7
 - Quick Calibration Procedure 3-1
 - Span Adjustment Range 3-4
 - Static Pressure Span Correction Factor 3-9
 - Zero Adjustment Range 3-4
 - Zero and Span Adjustment 3-6
 - Certifications
 - Hazardous Locations Certifications 2-12
 - Intrinsic Safety Entity Parameters 6-4
 - Circuit Side of Electronics Housing 2-3
 - Closed Vessels
 - Dry Leg Condition 2-14
 - Liquid Level Measurement 2-14
 - Wet Leg Condition 2-15
 - Conditions
 - General 2-1
 - Conduit Sealing 2-10
 - Configuration
 - LCD Meter 4-3
 - Standard 6-8
 - Connecting the Electrical Housing to the Sensor 5-8
 - Considerations
 - Mechanical 2-1
 - Cover Removal 4-4
 - Cover Replacement 4-5
- ## D
- Damping Adjustment 3-8
 - Data Flow with Calibration Options 3-3
 - Diagnostics
 - Hardware Diagnostics 5-1
 - Diagrams
 - Installation Diagrams 2-11
 - Dimensional Drawing 2-2
 - Disassembly
 - Transmitter Disassembly 5-4
 - Drain/Vent Valves 2-7
 - Drawings 2-2
 - Approval A-1
 - Dry Leg Condition
 - Liquid Level Measurement 2-14

E

- Electrical Considerations 2-8
 - Grounding 2-11
 - Power Supply 2-10
- Elevated or Suppressed Zeros 3-7
- Elevation and Suppression Jumper Settings 3-5
- Environmental Considerations
 - Grounding 2-11
 - Grounding Effects 2-12
 - Hazardous Locations Certifications 2-12
- Environmental Requirements 2-3
 - Conduit Sealing 2-10
 - Electrical Considerations 2-8
 - Mounting Brackets 2-5
 - Mounting Effects 2-4
 - Mounting Requirements 2-7
 - Power Supply 2-10
 - Process Connections 2-4
 - Wiring 2-9
- Exterior of Electronics Housing 2-3

F

- Filter Terminal Block (Option Code R2) 4-8
- Filter Terminal Blocks
 - Installation 4-8
- Functional Specifications 6-1

G

- Gas
 - Mounting Requirements 2-7
- General Considerations 2-1
- Glossary of terms G-1
- Grounding 2-11
 - Effects 2-12
 - Effects on Accuracy for Fast Sample Computers 2-13
 - Signal Wiring 2-11
 - Transmitter Case 2-11

H

- Hardware Diagnostics 5-1
- Hazardous Locations
 - Certifications 2-12
- Housing Rotation 2-3

- I**
 - Impulse Piping 2-8
 - Installation Diagrams 2-7
 - Information Storage 4-5
 - Installation 2-1, 4-8
 - Environmental Requirements 2-3
 - General 2-1
 - Mechanical Considerations 2-1
 - Mounting Bracket Options 2-6
 - Power Supply Load Limitations 2-10, 6-2
 - Installation Diagrams 2-11
 - Impulse Piping 2-7
 - Intrinsic Safety Entity Parameters 6-4
 - Introduction 1-1
 - Using This Manual 1-1
- L**
 - LCD Meter Configuration
 - Position the Decimal Point and Select the Meter Function 4-4
 - Remove the Cover 4-4
 - Replace the Cover 4-5
 - Set the Display Equivalent to a 20 mA Signal 4-5
 - Set the Display Equivalent to a 4 mA Signal 4-5
 - Store the Information 4-5
 - LCD Meters 4-3
 - LCD Meter Assembly 4-5
 - LCD Meter Configuration 4-3
 - LCD Meter Specifications 4-6
 - Linearity Adjustment 3-7
 - Liquid
 - Mounting Requirements 2-7
 - Liquid Level Measurement
 - Bubbler System in Open Vessel 2-16
 - Closed Vessels 2-14
 - Dry Leg Condition 2-14
 - Open Vessels 2-14
 - Wet Leg Condition 2-15
 - List of Spare Parts 6-13
- M**
 - Maintenance and Troubleshooting 5-1
 - Hardware Diagnostics 5-1
 - Reassembly Procedure 5-8
 - Return of Material 5-10
 - Transmitter Disassembly 5-4
 - Mechanical Considerations 2-1
 - Dimensional Drawing 2-2
 - Meter Configuration
 - LCD Meter Configuration 4-3
 - Meters
 - Analog Meters 4-3
 - LCD Meters 4-3
 - Optional Plug-in Meters 5-10
 - Mounting Brackets 2-5, 4-1
 - Mounting Bracket Options 2-6, 4-2
 - Mounting Effects 2-4
 - Mounting Requirements 2-7
 - Drain/Vent Valves 2-7
 - Impulse Piping 2-8
 - Taps 2-7
 - Multimeter
 - Connecting 2-10
- O**
 - Open Vessels
 - Liquid Level Measurement 2-14
 - Optional Plug-in Meters 5-10
 - Options 4-1
 - Analog Meters 4-3
 - LCD Meters 4-3
 - Mounting Brackets 4-1
 - Terminal Blocks 4-7
 - O-ring Installation 5-8
 - Output Code Availability 6-2
- P**
 - Parts List 6-13
 - Performance Specifications 6-6
 - Physical Specifications 6-8
 - Piping
 - Impulse Piping 2-8
 - Position the Decimal Point and Select the Meter Function 4-4
 - Power Supply 2-10
 - Installation Diagrams 2-11
 - Load Limitations 2-10, 6-2
 - Preliminary Precaution 5-8
 - Process Connections 2-4
 - Process Flange Orientation 2-3
 - Process Sensor Body Removal 5-5
 - Sensor Module Checkout 5-7
- Q**
 - Quick Calibration
 - Quick Calibration Procedure 3-1
 - Transmitter Data Flow 3-3
- R**
 - Rangeability 6-1
 - Reassembly Procedure 5-8
 - Backup Ring and O-ring Installation 5-8
 - Connecting the Electrical Housing to the Sensor 5-8
 - Optional Plug-in Meters 5-10
 - Preliminary Precaution 5-8
 - Remove the Cover 4-4
 - Removing the Sensor from the Electrical Housing 5-6
 - Replace the Cover 4-5
 - Requirements
 - Environmental 2-3
 - Retrofitable Transient Terminal Block (Option Code R9) 4-8
 - Return of Material 5-10
- S**
 - Sensor
 - Sensor Body Removal 5-5
 - Sensor Module Checkout 5-7
 - Sensor Removal 5-6
 - Set the Display Equivalent to a 20 mA Signal 4-5
 - Set the Display Equivalent to a 4 mA Signal 4-5
 - Signal Wiring 2-11
 - Span Adjustment Range 3-4
 - Spare Parts List 6-13
 - Specifications and Reference Data 6-1
 - Functional Specifications 6-1
 - Model 1151 Transmitter Range Availability 6-1
 - Output Code Availability 6-2
 - Performance Specifications 6-6
 - Physical Specifications 6-8
 - Rangeability Table 6-1
 - Spare Parts List 6-13
 - Static Pressure Span Correction Factor 3-9
 - Steam
 - Mounting Requirements 2-7
 - Store the Information 4-5
 - Suppressed Zeros
 - Elevated Zeros 3-7
 - Systematic Error Correction 5-2

T

- Taps 2-7
- Terminal Blocks 4-7
 - Exploded View (Figure 5-5) 4-9
 - Filter Terminal Block (Option Code R2) 4-8
 - Retrofitable Transient Terminal Block (Option Code R9) 4-8
 - Specifications 4-10
 - Transient Protection and Filter Terminal Block (Option Code R1) 4-8
- Terminal Connections 2-9
 - Electrical Considerations 2-9
- Terminal Side of Electronics Housing 2-3
- Transient Protection
 - Installation 4-8
- Transient Protection and Filter Terminal Block (Option Code R1) 4-8
- Transmitter
 - Case 2-11
 - Data Flow 3-3
 - Disassembly 5-4
 - Exploded View 5-5
 - Overview 1-2
 - Quick Calibration 3-1
 - Range Availability (1151) 6-1
- Transmitter Disassembly
 - Process Sensor Body Removal 5-5
 - Removing the Sensor from the Electrical Housing 5-6
 - Sensor Module Checkout 5-7
- Transmitter Reassembly 5-8
 - Backup Ring and O-ring Installation 5-8
 - Connecting the Electrical Housing to the Sensor 5-8
 - Optional Plug-in Meters 5-10
 - Preliminary Precaution 5-8

U

- Using This Manual 1-1

V

- Vent/Drain Valves 2-7
- Vessels
 - Open/Closed 2-14

W

- Wet Leg Condition
 - Example (Figure 4-6) 2-15
 - Liquid Level Measurement 2-15
- Wiring 2-9
 - Electrical Considerations 2-9

Z

- Zero Adjustment Range 3-4
 - Elevation and Suppression Jumper Settings 3-5
- Zero and Span Adjustment 3-6

Rosemount Inc.
8200 Market Boulevard
Chanhassen, MN 55317 USA
Tel 1-800-999-9307
Telex 4310012
Fax (612) 949-7001
© 1997 Rosemount, Inc.



<http://www.rosemount.com>



00809-0100-4360

REV. AA

ROSEMOUNT®

FISHER-ROSEMOUNT™ Managing The Process Better.™