

8900 Multi-Parameter Controller

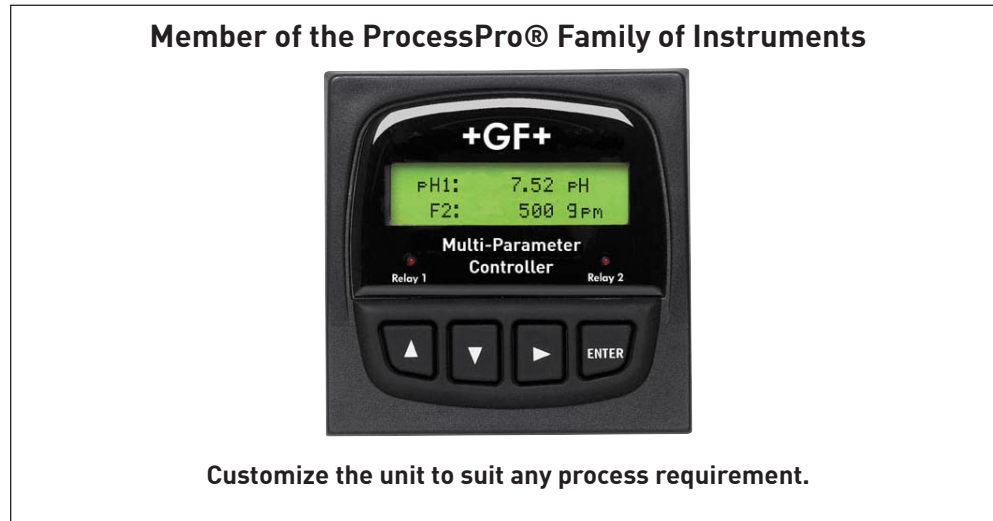

Features

- Measures Flow, pH, ORP, Conductivity, Pressure, Level and Temperature
- Multi-language display
- 1/4 DIN enclosure
- Up to 4 analog outputs
- Up to 8 relays
- 12 to 24 VDC or 85 to 264 VAC Power
- Digital Communication for extended cable lengths and easy wiring
- Accepts 4 to 20mA output devices when used with 8058 signal converter
- Available with 2, 4 or 6 channels
- Two BTU calculations

Description

The Signet 8900 Multi-Parameter Controller takes the concept of modularity to the extreme. Each 8900 is field commissioned with the users specified combination of inputs, outputs, and relays using simple-to-install modular boards into the base unit. To assemble a controller, there is a choice of two base units offered with a choice of back-lit LCD or vacuum fluorescent display. Then, continue building with a selection of plug-in modules which accepts any of the Signet sensors listed below, and/or other manufacturer's sensors via a 4 to 20mA signal converter (Signet Model 8058). To complete your unit, choose a power module with universal AC line voltage or 12 to 24 VDC. If more features are needed, analog output and relay modules are available

and easily installed. Plus, the 8900 will support up to four additional relays via an external relay module.

There are other notable features that the 8900 offers. For instance, digital input to the 8900 enables longer cable runs and simplified wiring with minimal noise interference. Advanced relay logic provides operators an "and/or" logic to produce high/low alarms. Derived measurements include difference, sum, ratio, percent recovery, percent rejection, and percent passage - and now with BTU. The menu system can be programmed to display in multi-languages including English, German, French, Spanish, Italian, and Portuguese.

Applications

- RO/DI System Control
- Media Filtration
- Pure Water Production
- Demineralizers
- Chemical Processing
- Metal & Plastics Finishing
- Fume Scrubbers
- Proportional Chemical Addition
- Cooling Tower & Boiler Protection
- Wastewater Treatment
- Aquatic Animal Life Support Systems
- Rinse Tank

System Overview

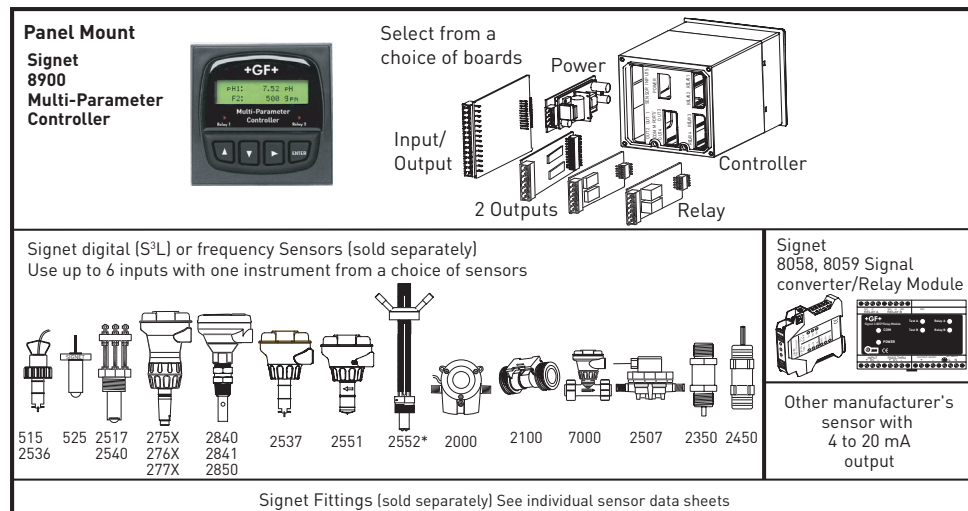

* Check local Georg Fischer sales office for availability.

System Overview (continued)

There are hundreds of system types that can be set up with the 8900. The examples below illustrate various sensors in different installation schemes. Wiring topology for point-to-point, daisy-chain, multi-drop, or a

combination of these are listed in each example. Digital sensor outputs allow for long cable runs with high noise immunity. See Wiring section for allowable cable lengths.

Example 1:

- 8900 input module: Two inputs
- Sensors connected: Signet 2540 flow (frequency) and 2750 with 2754 pH sensors
- Wiring configuration: Point-to-point

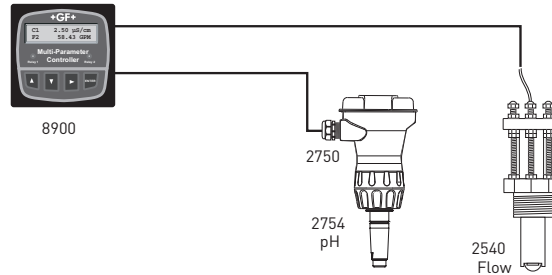

Notes:

1. External relays can be used with any input module and does not consume a sensor input channel (Model 8059)
2. Model 8058 Signal Converter can be used with any input module.

Example 2:

- 8900 input module: Four inputs
- Sensors connected: Signet 2350 temp. sensor, 2850 with 2841 conductivity, and two 2450 pressure sensors
- Wiring configuration: Daisy-chain

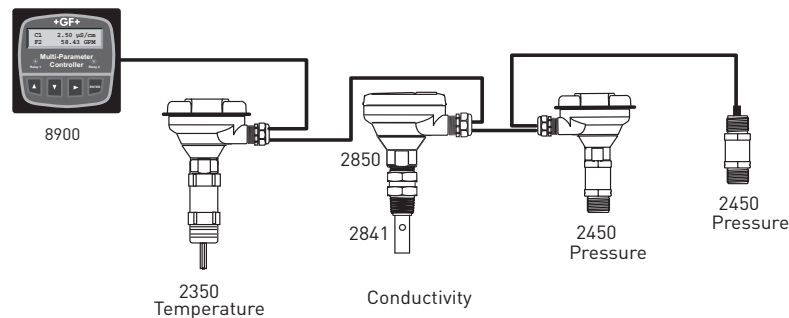

Example 3:

- 8900 input module: Six inputs
- Sensors connected: Signet 2350 temp. sensor, 2850 with 2840 conductivity, 2450 pressure, 2750 with 2754 pH, and 515 and 2536 flow (frequency) sensors
- External Devices: Signet 8059 external relay module
- Wiring configuration: Combination of Point-to-point and Multi-drop

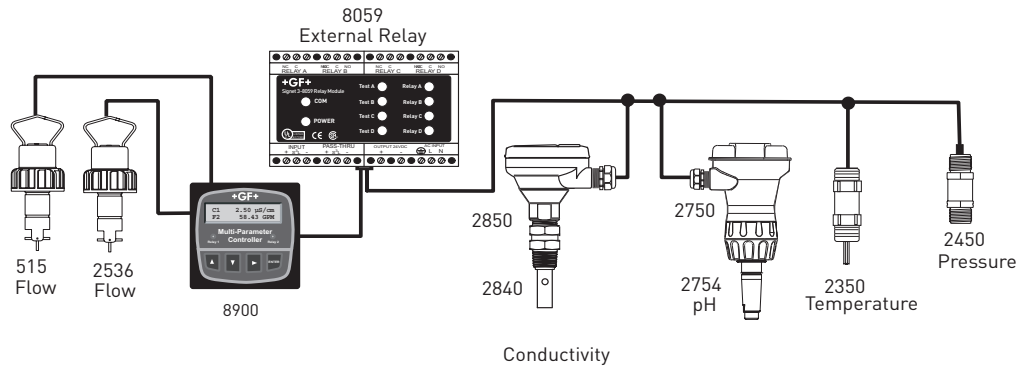

Example 4:

- 8900 input module: Four inputs
- Sensors connected: Signet 2507 flow (frequency) and 2750 with 2754 pH sensors; Other manufacturers dissolved oxygen and level sensors with 4 to 20 mA output
- External Devices: Signet 8058 signal converter - 4 to 20 mA to digital (S³L)
- Wiring configuration: Combination of Point-to-point and Daisy-chain

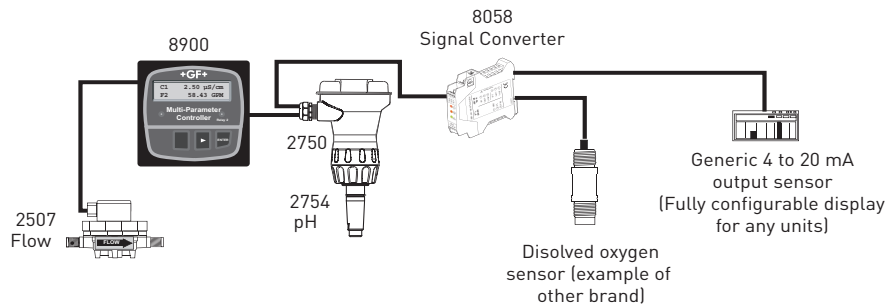

Wiring Options:

- **Point-to-point** wiring is direct wiring of individual devices into the controller. This wiring topology is applicable for all inputs.
- **Daisy-chain** wiring allows sequential connection from one device to the next by using junction boxes. This wiring topology is applicable for digital (S³L) inputs only.
- **Multi-drop** wiring allows drops from a single bus cable. Junction boxes can be used for the 3-way junctions that are formed with this wiring scheme. This wiring topology is applicable for digital (S³L) inputs only.

Specifications

General

Configurability: Modular (completely field-commissionable)

No. of input channels: 2, 4, or 6

Compatible sensors: See System Overview

Input signal types:

- Digital (S³L): Serial ASCII, TTL level 9600 bps
- Frequency: 0 to 1500 Hz
- Accuracy: 0.5% of reading

Measurement types:

Flow, pH, ORP, Conductivity/Resistivity, Pressure, Temperature, Level, or any device with 4 to 20mA output

Derived measurements:

Sum, Difference, Ratio, % Recovery, % Reject, % Passage, Power (BTU)

No. of relays supported:

Available in pairs: 2, 4, 6 or 8 (8 Dry-Contact and/or 4 Solid State)

No. of analog outputs:

Available in pairs: 2 or 4 (active and/or passive 4 to 20mA; and/or 0 to 5/10 VDC)

Enclosure and Display

- Enclosure Rating: NEMA 4X/IP65 (front face only)
- Case material: PBT
- Panel Gasket: Silicone Sponge
- Window: Self-healing polyurethane-coated polycarbonate
- Keypad: 4-buttons, highly tactile and audible
Injection-molded silicone rubber seal

Display:

- Alphanumeric 2 x 16 back-lit LCD or Vacuum Fluorescent (VF) versions
- Update rate: 1 second
- Accuracy: Sensor dependent
- VF Brightness: 4 intensity levels
- LCD Contrast: 4 settings
- Languages Available: English, French, Spanish, German Italian, and Portuguese

Display ranges (see sensor specifications for actual measurement limits):

- pH: -2.00 to 15.00 pH
- pH Temp.: -40°C to 150°C (-40°F to 302°F)
- ORP: -9999 to +9999 mV
- Flow rate: 0.0000 to 999999 units per second, minute, hour or day
- Totalizer: 0.00 to 99999999 units
- Conductivity: 0.0000 to 999999 μ S, mS, PPM & PPB (TDS), k Ω , M Ω
- Cond. Temp.: -99.9°C to 250°C (-148°F to 482°F)
- Temperature: -99.9°C to 999.9°C (-148°F to 999.9°F)
- Pressure: -99.99 to 9999 psi, kPa, bar

Display ranges (continued)

- Level: -99999 to 99999 m, cm, ft, in., %
- Volume: -99999 to 999999 m³, ft³, in³, cm³, gal, L, kg, lb, %
- Other (4 to 20mA): -99999 to 999999 user selectable units

Environmental

Ambient Operating Temperature:

- Back-lit LCD: -10°C to 55°C (14°F to 131°F)
- VF Display: -10°C to 50°C (14°F to 122°F)

Storage Temp.:

-15°C to 80°C (5°F to 176°F)

Relative Humidity:

0 to 95%, non-condensing

Maximum Altitude:

- 2,000m (6,560 ft.)
- 4,000m (13,123 ft.); use only DC power supply and, if applicable, solid state relays to maintain UL safety standard up to this altitude .

Electrical

Power Requirements (AC or DC via Power Modules)

- Universal AC: 85 to 240 VAC, 50-60 Hz, 24 VA max.
- DC: 9.9 to 26.4 VDC unregulated, 7 Watts max.

Output Power to Sensors:

5VDC up to 40mA total

Terminal type:

Screw-clamp, removable via plug-in modules.

Analog Outputs (via I/O Modules and Output Modules) All analog outputs are freely assignable to any channel

4 to 20mA Output:

Endpoints are adjustable and reversible:

- Minimum default: 4.0 mA; user adjustable from 3.8 to 5.0 mA
- Maximum default: 20.00 mA; user adjustable from 19.0 to 21.0 mA

Test mode:

Produces an adjustable 4 to 20mA signal for functional verification of each output circuit

Isolation: Up to 48 V AC/DC

Error condition:

22.1 mA (default state when output source not configured)

Update rate: 100ms

Accuracy:

$\pm 32\mu$ A over entire operating temperature range

Dimensions

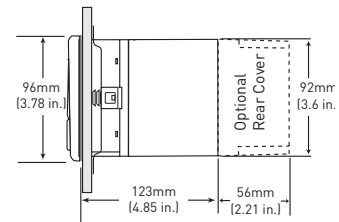
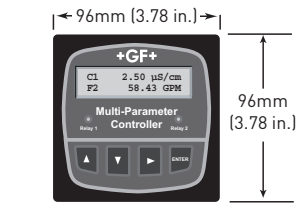

Specifications (continued)

Analog Outputs (Continued)

Passive 4 to 20mA

- Voltage: 12 to 24VDC \pm 10%
- Max. Impedance:
 - 250 Ω @ 12 VDC
 - 500 Ω @ 18 VDC
 - 750 Ω @ 24 VDC
- Active 4 to 20mA
- Max. Impedance: 650 Ω

0 to 5/10 VDC Output:

Output range:

0 to 5 VDC or 0 to 10 VDC, software selectable

Endpoints are adjustable and reversible:

- Minimum default: 0 VDC; user programmable from 0 to 0.5 VDC
- Maximum default: 5 VDC; user programmable from 4.5 to 5.5 VDC, or 9.5 to 10.5 VDC

Output load: 10k Ω minimum

Test mode:

Produces an adjustable signal for functional verification of each output circuit

Isolation: Up to 48 V AC/DC

Error condition:

0 VDC (default state when output source not configured)

Update rate: 100mS

Accuracy:

\pm 20mV over entire operating temperature range

Resolution: 5mV

Power Supply Rejection: 0.5 mV/V

Relay Modules

All relays are freely assignable to any channel.

- Internal relay modes of operation: Off, Low, High, Window, Pulse, Pulse Width Modulation, USP, Volumetric, Pulse, Totalizer Volume, Advanced, % Rejection
- External relay modes of operation: Off, Low, High, Window, Pulse Width Modulation, USP, Totalizer Volume, Advanced, % Rejection

Hysteresis: User adjustable

Time Delay: 0 to 6400 seconds

- Advanced relay: Use "AND/OR" logic along with relay sources to trigger a relay. High/Low modes available for each of the 3 sources.

- Solid State Relays: (non-mechanical switches)

Normally open/closed operation:

Software selectable

Maximum pulse rate:

- 600 pulses/min. [volumetric pulse & PWM modes]
- 400 pulses/min. (prop. pulse mode)

Maximum voltage rating:

30 VDC or 42 VAC p-p

Current rating:

50mA DC or 50mA AC RMS

On-state impedance: 30 Ω or less

Off-state leakage: 400nA or less, AC or DC

Isolation: Up to 48 V AC/DC

Transient protection:

Embedded, up to 48 V over-voltage

- Dry-contact Relays: (mechanical contacts)

Type: SPDT

Form: C

Maximum pulse rate:

- 600 pulses/min. [volumetric pulse & PWM modes]
- 400 pulses/min. (prop. pulse mode)

Maximum voltage rating:

30 VDC or 250 VAC

Current rating: 5A

Shipping Weights:

- Base unit: 1.0 kg (2.25 lb.)
- Power Module: 0.12 kg (0.25 lb.)
- I/O Module: 0.12 kg (0.25 lb.)
- Output Module: 0.12 kg (0.25 lb.)
- Relay Module: 0.12 kg (0.25 lb.)

Standards and Approvals

- CE, UL
- Manufactured under ISO 9001: 2000 for Quality and ISO 14001:2004 for Environmental Management

Installation of Modules with the base unit

3-8900/3-8900-VF

One base unit is required to build a functional 8900. It is offered with a backlit LCD or a Vacuum Fluorescent Display. Programming the unit is done simply via the push-button keypad. The unit can be tailored to display in

English, German, French, Spanish, Italian, and Portuguese. The two line display allows for easy programming, navigation, and viewing of each channel.

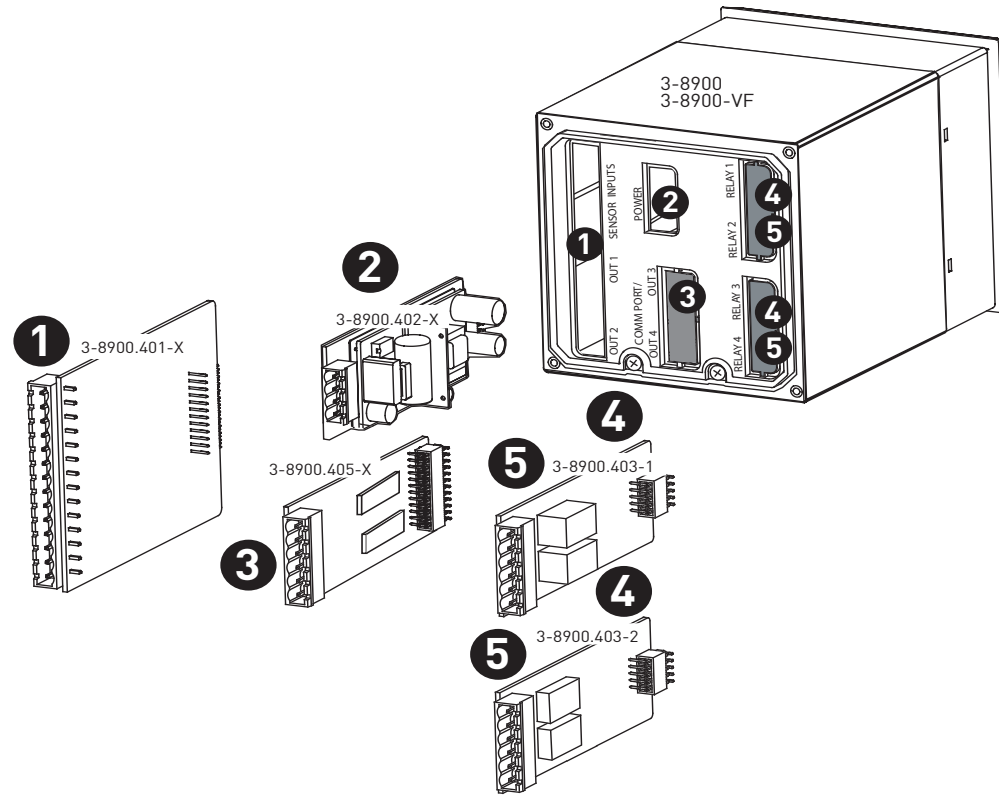

1. I/O module

One I/O module is required to build a functional 8900. I/O modules are offered for 2, 4, or 6 sensor inputs, with or without 2 milliamp or voltage outputs. Users can select two additional outputs via the output module.

2. Power module

One power module is required to build a functional 8900. The power module is offered for universal 110/220 VAC or 12 to 24 VDC (This module can be powered by optional external relays (see ordering information for more details).

3. Output module

Output modules are optional when building an 8900. This module can be used in addition to other outputs that are available in the I/O modules. Active current and voltage outputs are powered by the 8900. Passive outputs require an outside 12 - 24 VDC power supply. All outputs are assignable to any input channel.

4 & 5. Relay modules

Relay modules are optional when building an 8900. Relay modes of operation include off, low, high, window, USP, totalizer volume, advanced, pulse, pulse width modulation and volumetric pulse. The advanced relay option for "AND/OR" logic is used for up to 3 conditions. For instance, a relay will go to high/low if "a" is true and "b" or "c" is false. One or two relay modules can be installed into the 8900. One additional external relay module can also be used at the same time (See optional external relay ordering information.) All relays are assignable to any input channel.

Installation of Modules: Modules simply plug in by sliding into the base unit on rails. They are held securely in place by the rear panel. Changes and upgrades can be made in the field at any time.

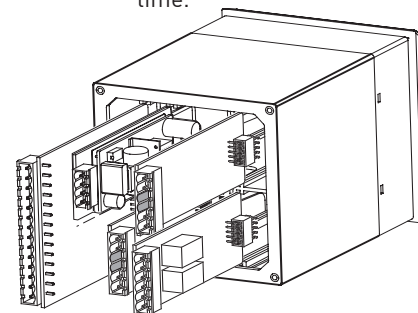

Model 8900

Ordering Notes:

- 1) Building a functional unit requires a base unit, I/O module, and power module.
- 2) Output options are available on I/O modules and additional output modules can be used. The 8900 can support up to four outputs.
- 3) Up to two internal relay modules can be used simultaneously; additional external relays can also be used. The 8900 can support up to eight relays.
- 4) A maximum total of two frequency sensors can be used with any input card.
- 5) A total of six digital inputs or four digital with two frequency inputs can be used.
- 6) The 8900 boards can be removed or inserted at any time to add /remove inputs, outputs, and relays.
- 7) The 8900 can be reconfigured with new sensor types by simple reprogramming.

Please refer to Wiring, Installation, and Accessories sections for more information.

Ordering Information

To build a functional 8900 controller, choose a base unit, power module, and input/output (I/O) module. Additional outputs and relays are available, if needed.

Mfr. Part No.	Code	Description
Base units, required; choose one		
3-8900	159 000 868	Base unit with back-lit LCD
3-8900-VF	159 000 869	Base unit with Vacuum Fluorescent display
I/O (input/output) modules, required; choose one		
3-8900.401-1	159 000 870	Dual (2) Input (no outputs)
3-8900.401-2	159 000 871	Dual (2) Input with Two Passive* Loop Outputs
3-8900.401-3	159 000 872	Dual (2) Input with Two Active Loop Outputs
3-8900.401-4	159 000 873	Dual (2) Input with Two Voltage Outputs
3-8900.401-5	159 000 874	Quad (4) Input (no outputs)
3-8900.401-6	159 000 875	Quad (4) Input with Two Passive* Loop Outputs
3-8900.401-7	159 000 876	Quad (4) Input with Two Active Loop Outputs
3-8900.401-8	159 000 877	Quad (4) Input with Two Voltage Outputs
3-8900.401-9	159 000 968	Six Inputs (no outputs)
3-8900.401-10	159 000 969	Six Inputs with Two Passive* Loop Outputs
3-8900.401-11	159 000 970	Six Inputs with Two Active Loop Outputs
3-8900.401-12	159 000 971	Six Inputs with Two Voltage Outputs
Power modules, required; choose one		
3-8900.402-1	159 000 878	110/220 VAC Power Module
3-8900.402-2	159 000 879	12 to 24 VDC Power Module
Optional output modules - choose one		
3-8900.405-1	159 000 883	Two Passive* Current Loop Outputs
3-8900.405-2	159 000 884	Two Active Current Loop Outputs
3-8900.405-3	159 000 885	Two 0 to 5 and/or 0 to 10 VDC Outputs
Optional relay modules - choose one or two		
3-8900.403-1	159 000 880	Two Dry Contact Relays
3-8900.403-2	159 000 881	Two Solid State Relays
Optional external relays - choose one**		
3-8059-2	159 000 770	Two dry-contact relays; requires 12 to 24 VDC
3-8059-2AC	159 000 771	Two dry-contact relays; requires 100 to 240 VAC; supplies power to the 12 to 24 VDC power module
3-8059-4	159 000 772	Four dry-contact relays; requires 12 to 24 VDC
3-8059-4AC	159 000 773	Four dry-contact relays; requires 100 to 240 VAC; supplies power to the 12 to 24VDC power host device

* Passive outputs require an outside power source

** See individual product page for the 8059 External Relay Modules.

Accessories and Replacement Parts

Mfr. Part No.	Code	Description
Mounting		
3-8050.392	159 000 640	Panel adapter, 1/2 DIN to 1/4 DIN
3-8050.395	159 000 186	Splashproof rear cover
3-0000.596-1	159 000 892	1/4 DIN wall mount bracket, 6.5 in. (use if no rear cover is installed)
3-0000.596-2	159 000 893	1/4 DIN wall mount bracket, 9 in. (use if rear cover is installed)
3-5000.399	198 840 224	Panel adapter, 5 x 5 in. to 1/4 DIN
3-5000.598	198 840 225	Surface mount bracket
Power Supplies		
7300-7524	159 000 687	24 VDC Power Supply 7.5 W, 300mA
7300-1524	159 000 688	24 VDC Power Supply 15 W, 600mA
7300-3024	159 000 689	24 VDC Power Supply 30 W, 1.3 A
7300-5024	159 000 690	24 VDC Power Supply 50 W, 2.1 A
7300-1024	159 000 691	24 VDC Power Supply 100 W, 4.2 A
Miscellaneous		
3-8050.396	159 000 617	RC Filter kit (for relay use), 2 per kit